

**McMartin**

**Scientific**

**Report**

**TED L. GUNDERSON, F.B.I. SENIOR SPECIAL AGENT-IN-CHARGE, RET.**  
2118 Wilshire Blvd. ♦ Suite 422 ♦ Santa Monica, CA ♦ Ph: (310) 364-2280 ♦ (310) 650-5674

## **PROFESSIONAL EXPERIENCE**

- 1979 - Present      **TED L. GUNDERSON & ASSOCIATES, Santa Monica, California.**  
Founder, owner and operator of this international security consulting and investigation firm.
- Hosts the "Ted Gunderson Intelligence Report" radio talk show, weekdays as follows:
1. American Freedom Satellite Network, GE 1 103° West (2° to the West of Space Net 4) Channel 7, Sub Audio 5.8 Frequency 10AM to 12PM Central Standard Time (C.S.T.)
  2. WWCW Short Wave Radio 12.160 Frequency, 11AM to 12PM (C.S.T.)
- 1984                      **LOS ANGELES OLYMPIC COMMITTEE**  
Security and Anti-Terrorism Consultant
- 1981-1982              **CALIFORNIA NARCOTICS AUTHORITY**  
Appointed by Governor of California as Narcotics Consulting Agent
- 1979                      **PAN AMERICAN GAMES, San Juan, Puerto Rico**  
Security and Anti-Terrorism Coordinator  
Special Appointee of United States Attorney General Griffin B. Bell
- 1951-1979              **FEDERAL BUREAU OF INVESTIGATION**
- |         |  |
|---------|--|
| 1977-79 | Senior Special Agent-in-Charge, Los Angeles, California                                  |
| 1973-77 | Special Agent-in-Charge of Memphis, Tennessee and Dallas, Texas                          |
| 1973    | Chief Inspector  |
| 1965-73 | Assistant Special Agent-in-Charge, New Haven, Connecticut and Philadelphia, Pennsylvania |
| 1960-65 | Special Agent Supervisor, FBI Headquarters, Washington, D.C.                             |
| 1951-60 | Special Agent  |

Received many other awards, including Law Enforcement Officer of The Year. Author of "How to Locate Anyone Anywhere Without Leaving Home" (Penguin Books 1989) and other publications. Has appeared on numerous radio and TV shows including, "Larry King Live", "Geraldo", "48 Hours", "Hard Copy", "Inside Edition" among others. Currently forming an organization known as "Current and Former FBI Agents For Honest Government".

**THE TUNNELS FOUND AT THE McMARTIN PRE-SCHOOL  
A PRELIMINARY REPORT**

A formal report will be released when forensic tests are concluded.

• **45 foot tunnel**

- 9 foot wide subterranean entrance found under west wall of the "Dog" room (Classroom 4, Ray Buckey's classroom).
  - Avocado tree roots cut on both sides of the entrance.
  - Disney bag, "Copyright 1982," found 4-1/2 feet below the classroom floor and 3" to 6" in from entrance and under foundation, Classroom 4.
- Tunnel proceeded south, then east 45 feet through Classrooms 4 and 3, and north, then east 10 feet within Classroom 4.
  - Tunnels were 30" wide, 44" to 46" deep, with top of the tunnel 30" under the classroom floor.
  - The footing between Classrooms 3 and 4 was arched where the tunnel passed underneath and 12" shorter in depth at this location than same footing 12 feet to then north.
    - Four large, upright containers were found in the tunnel under the arch, obviously hand placed.
- A 9 foot wide chamber was found along the tunnel under Classroom 4. Top of chamber and top of sections of the tunnel had layers of plywood covered with tar paper which had apparently been supported by cinder blocks and 2" x 2" and 2" x 4" wooden posts found underneath.
- Tunnel features made it evident that tunnel was hand dug.

• **7 foot tunnel extending into the triplex next door**

- Tunnel extended from the bathrooms off the office and Classroom 1 to the front yard of the triplex next door. Front yard concealed from street by three-car garage.
- Children described entrance and exiting tunnel in triplex yard exactly where tunnel and exit were found.
- 1 39" x 41" area under a hole cut in this neighbor's bathroom floor had been excavated and subsequently filled.

• **Other significant facts**

- A small, white plastic plate with three pentagrams hand drawn on top of light green paint was found by the archaeologists in the stratified dirt in the play yard.
  - Per historical archaeologist, pentagrams were hand drawn by an adult and not part of the manufacturer's design.
- Many other artifacts found, whose analyses will be released upon completion of tests.
- No doorknobs were on Classroom 3 door, only a dead bolt lock.
- Each classroom had on and off light switch labeled "Fire Alarm." System did not connect to fire station but was used as an alert within the school.
- More than 2000 artifacts were found under the school floor, including over 100 animal bones.

Due to severe time constraints our archaeology team was unable to further explore the extent of the tunnel networks. Above documented through photographs, notes, graphs, diagrams and charts.

Dr. Gary Stickel, Archaeologist  
Ted L. Gunderson, Project Coordinator (former FBI agent)

ARCHAEOLOGICAL INVESTIGATIONS OF THE  
McMARTIN PRESCHOOL SITE,  
MANHATTAN BEACH, CALIFORNIA

by

E. Gary Stickel, Ph.D.

## Introduction

The world has never been quite the same since March 22, 1984. On that date the Los Angeles County District Attorney described an unheard-of level of outrage: the sexual assault, pornographic exploitation and sadistic terrorizing of dozens, maybe hundreds of tiny children in a respected Manhattan Beach preschool. Buttressed by a similar case in Jordan, Minnesota and followed by at least fifty outbreaks of apparently identical accusations throughout the United States, there were implications that a whole generation of children was targeted for subversion by an invisible horde of satanic cult terrorists.

The investigators and the parents who heard the children's stories firsthand tended to believe in the literal truth of apparently fantastic stories. Others, more removed from emotional rapport with the children, became aggressively skeptical, insisting there was no evidence and no rational precedent for an occult conspiracy. Journalists exploited the controversy and kindled the fear, announcing a state of panic among parents— a national hysteria. Others, drawing on the theory conceived by criminal defense attorneys, blamed therapists and investigators for implanting the stories through impressionistic children caught up in a "witch hunt" for child abusers.

More sober observers waited for evidence. If animals were killed, where were the remains? If pornography was produced, where were the pictures? And if children were taken underground for ceremonies and for transport to off-campus locations, where were the tunnels? In case after case there was spectacular failure to produce the definitive proof. Prosecutions and convictions, when they occurred, depended on believing the children. In the absence of self-evident substance, the press and the public hung on the outcome of adversarial argument.

The McMartin case was the first to be announced and the last to be decided. Following the two longest and most expensive criminal trials in history and a third brief challenge to one remaining defendant, the McMartin "case" ended on July 27, 1990, without a single conviction. The name "McMartin" has since become emblematic of prosecutorial debacles, overzealous investigations, and mass hysteria. Parents are cast as vigilantes in the metaphoric review and therapists are condemned as the real abusers of children. With these new scapegoats for distrust, children could once more be entrusted to benevolent strangers.

But the most vital questions of the epidemic of the eighties are not resolved through criminal prosecution, whether or not there is a conviction of designated defendants. Those who hold to their belief in the children are not impressed by the vagaries of criminal justice. Parents were less concerned with determining guilt than discovering what had been done to their children. When children awoke screaming against unutterable fears, criminal charges of sexual touching became irrelevant to parental suspicions of psychological invasion. The uncharged offenses remain the most troubling: Who were the unidentified strangers? Why talk of forays to neighborhood stores and churches? Why claim trips to impossibly distant locations? Why insist there were underground rooms and tunnels?

While these most implausible claims were avoided by prosecutors and exploited as *de facto* fantasy by defense, they remain the most provocative enigmas for those who would understand the experience of children who become plagued with such fears. Beyond the elusive and limited goals of criminal investigation, beyond proving *who* may have sexually assaulted these children, it is ultimately more important to the future of childhood and to the security of families to determine *what* happened to the children, in the true and broadest sense, and whether the children were manipulated through outside malice or merely via parental misunderstanding.

Throughout the agonizing process of the McMartin investigation, parents insisted on the crucial reality of the reported tunnels, while outsiders scoffed at the stories. Parents, risking further stigma as vigilantes, started digging and compelled attention to underground phenomena. Prosecutors, forced to a showdown, commissioned a superficial search of open terrain and, *without going under the concrete floor of the preschool*, branded the tunnel stories as bogus. Once the tunnels were officially discounted, attempts to explore for an underground reality were instant targets for ridicule:

The McMartin School was painstakingly probed for tunnels. None were found. . . . [The McMartin] parents have invested years believing in demonic conspiracies and underground nursery tunnels. (Until recently the parents were still digging. They came up with Indian artifacts). They have spoken unremittingly of such things, to the world and to their sons and daughters. They have told their children, over and over, that they were abused, then rewarded them for being traumatized. They have put them in therapy with adult fanatics who have done the same, and enrolled them as guinea pigs in the "research" projects of zealots.

The McMartin kids, and hundreds of others in ritual abuse spinoffs across the country, have spent years trapped in clans now extended to include psychologists, social workers and prosecutors—clans whose identity derives from a tent-revival belief in their children's imagined victimization.

(Nathan, D. What McMartin Started: The Ritual Sex Abuse Hoax. *The Village Voice*, XXXV [24], June 12, 1990, syndicated nationally. Also in Debbie Nathan's book, *Women and other Aliens, Essays from the US-Mexican Border*, as quoted in an editorial review, "Understanding Who Is Behind the Satanic Hoax", *NASVO NEWS/ICA VOCAL Newsletter*, 7 [3], Fall, 1991).

It should be important to know, once and for all, whether children described actual tunnels or imaginary voids. Journalists should know whether the parents found "Indian artifacts" or something more telling. Certainly it would be important to know if the parents commissioned an archeological investigation that was, in fact, more exhaustive and was conducted with more scientific rigor than the supposedly painstaking probe by the prosecutors.

If the stories of the children were bogus fantasies, there is no excuse for the tunnels discovered under the school. If there really were tunnels, there is no excuse for the glib dismissal of any and all of the complaints of the children and their parents.

It makes a difference to know the truth about the tunnels. This report offers new and unprecedented dimensions of truth.

Roland C. Summit, M.D.

## TABLE OF CONTENTS

1.0	Introduction .....	1
1.1	Introduction to the Project .....	1
1.2	Background of the Project .....	4
1.3	Preliminary Investigations of the Present Project .....	15
1.4	Project Research Design, Objectives and Methodology .....	23
2.0	Project Background .....	26
2.1	History of the Project Parcels .....	26
2.2	Geological/Natural History of Soil Deposit on the Site .....	29
3.0	Excavation Methodology and Methods .....	32
3.1	Site Excavation Methods .....	32
3.2	Method of Excavated Unit Selection .....	33
3.3	Use of Ground Penetrating Radar and Informant Reports for Unit Selection .....	35
4.0	Excavated Units, Recovered Data and Analysis .....	35
4.1	Unit Placement and Excavation .....	35
4.2	Results of Test Pit and Test Trench Search Excavations .....	37
4.3	Location and the Exploration of the Tunnel Under the North Axis of the Preschool .....	52
5.0	Ancillary Supporting Scientific Analysis by Consultants .....	83
5.1	Introduction to Supporting Scientific Team .....	83
5.2	Radiocarbon Analysis .....	83

5.3 Results of the Geological Study of the Site .....	83
5.4 Results of the Zooarchaeological (Faunal) Analysis .....	85
5.5 Results of the Selected Special Artifact Analysis .....	85
5.6 Results of the Electrical Analysis of the Preschool Building .....	88
5.7 Results of the Ground Penetrating Radar Study .....	88
6.0 Synthesis of Excavated Data and Scientific Support Studies .....	90
7.0 Conclusions .....	93
8.0 Recommendations .....	96
9.0 References Cited .....	97
10.0 Acknowledgements .....	104
11.0 Glossary .....	105

**APPENDICES:**

APPENDIX I: Scientific Support Studies .....	107
I.1 Introduction .....	107
I.2 Radiocarbon Analysis by Dr. Rainer Berger .....	108
I.3 a) Geological Study by Dr. Don Michael .....	110
b) Addendum to Geological Study by Dr. Don Michael .....	114
I.4 Zooarchaeological (Faunal) Analysis by Dr. Charles Schwartz .....	120
a) Initial Faunal Report, June 2, 1990 .....	120
b) Second Faunal Report, June 15, 1990 .....	126
I.5 Historical Artifact Analysis by Mr. Jeff Minard .....	139
I.6 Electrical Analysis of the Preschool Building by Mr. Jeff Hellman .....	155
I.7 Ground Penetrating Radar Study .....	159
APPENDIX II: Therapist Survey .....	167
APPENDIX III: Notes on the Project by Mr. Gerald E. Hobbs .....	170
III.1 Parents' 1990 Dig .....	171
III.2 Root Pattern Around Elm Tree .....	172
III.3 North Property Metal Detector Survey .....	173



III.4	Disney Bag and Avocado Root, Entrance to Tunnel	174
III.5	Notes on Avocado Tree	175
	a) Correspondence Clarifying Notes on Avocado Tree Roots	176
APPENDIX IV: Notes on the Investigation of the Neighboring Triplex		
	by Gerald E. Hobbs	177
APPENDIX V: Additional Project Notes		
V.1	Plumbing and Heaters in the Preschool Building	180
V.2	Attempt to Age Concrete Floor	181
V.3	Classroom #3 Door	182
V.4	Disney Bag and Avocado Tree Roots: Final Observations	184

ARCHAEOLOGICAL INVESTIGATIONS OF THE  
McMARTIN PRESCHOOL SITE,  
MANHATTAN BEACH, CALIFORNIA

by

E. Gary Stickel. Ph.D.

1.0 Introduction

1.1 Introduction to the Project

This report presents the findings relative to a formal archaeological investigation of the McMartin Preschool site, located in Manhattan Beach, California. The author was commissioned to conduct the archaeological investigation of the subject site based on a recommendation by Prof. Rainer Berger, then Chairman of the UCLA Interdisciplinary Archaeology Program. A group of parents whose children had been enrolled in the school had obtained provisional permission from the owner of the site to search for the tunnel(s) and underground room(s) which their children had described. The parents' initial excavation encountered artifacts whose significance was ambiguous because of the imprecise nature of their approach.

During the initial phase of the project (described below in Section 1.3), it became apparent that the project needed formal, qualified archaeological expertise in order to definitively resolve the questions of whether subterranean features (tunnels and rooms) were actually present at the site in question. Subsequently the author was retained to be the director of all archaeological work at the site. Due to the given time frame (see Section 1.2 below), there was only one month of time provided to us in which to conduct the field work. Hence all field work was completed in May, 1990.

Because the project involved archaeological investigations of a site dating to our own culture and to very recent times (i.e. the era between 1967 and 1990) we were conducting what is professionally referred to as an "historical archaeological" excavation. Historical Archaeology is a subfield of the science of Archaeology in general and it has its own relatively unique and distinct approach due to the fact it deals with sites that can be associated in many instances with known and documented people and events (see Noel-Hume 1975 and South 1977 for the methodology of Historical Archaeology). The latter is especially notable for the subject site since it was a key fixture in the now nationally known criminal case. The McMartin case is prominent in legal circles for having the distinction of being the longest running and the most expensive criminal trial in the history of U.S. jurisprudence (for a comprehensive report and a chronology of the case see the article in the national publication entitled the *State Peace Officer's Journal* by E.L. Wiley

1991: 66-90). A good visual summary of the case is available in the Emmy Award-winning segment from the Public Broadcasting System (PBS) MacNeil/Lehrer Newshour entitled "McMartin: Trial and Error" (MacNeil/Lehrer, 1990).

Given this background, the archaeological project became *de facto* a kind of forensic site search, even though the intent of the project was not to provide "evidence" for the case (the second trial was actually being tried concurrently with our dig). The Los Angeles County District Attorney's Office had made it clear that it had sufficient evidence for its case and would not consider using any additional data from our work. Very little has been written in the field of Archaeology on forensic archaeological investigations. The most notable exception is the book by Morse, Duncan and Stoutamire (1983) entitled *Handbook of Forensic Archaeology and Anthropology*. Information in that work was considered as part of the research developed for this project.

Despite the apparently confident opinion of the District Attorney's Office, the case was not successfully prosecuted (cf. Wiley, 1991). Although the verdict was disappointing to the parents, it was not unexpected due to their dissatisfaction with the manner in which evidence was gathered, both from their children and from the preschool site itself. A major point of dispute was that despite the fact that the children spoke of tunnels (Daily News, 1985; Daily Breeze, 1986a; 1986b; 1989; Easy Reader, 1988) and a "secret room" (Daily News, 1985; Daily Breeze, 1985a:) beneath the preschool building, no adequate investigation had been carried out prior to this described project. In addition, the statements made by several of the children of their involvement in what has been interpreted as bizarre interactions with adults had led to the interpretation on the part of some individuals that the children had been involved in strange rituals (Daily Breeze, 1986b; 1989; Easy Reader, 1988). However since no tangible evidence of such behavior (i.e. either subterranean tunnel/room use or ritual behavior) was presented as evidence by the District Attorney's Office, the credibility of the children's testimony was successfully assailed by the defense. Given this turn of events, the news media swung their emphasis to the defense position and to the chorus doubting any veracity in the children's statements.

The *de facto* avoidance by the criminal justice system of the more bizarre allegations leaves parents and clinicians burdened with interpreting the most confusing and alarming aspects of the children's descriptions. The implications of "ritual abuse" have been given credence by some clinicians (Braun, 1986; Kelley, 1988, 1989, 1990; Burgess, *et al*, 1990; Summit, 1988, 1989; Fallor, 1990; Snow and Sorenson, 1990; Bottoms, *et al*, 1991; Jones, 1991; Jonker and Jonker-Baker 1991; Young, *et al*, 1991; Smith, 1992; Goodwin, 1993), social scientists (Finkelhor and Williams, 1988), and governmental agencies (Wilson and Steppe, 1985; Office of Criminal Justice Planning, 1989-1990; Lloyd, 1990; Committee on Child Abuse Prevention, 1991; Wiley, 1991). The alarming nature of the descriptions of ritual in the absence of material evidence prompts others to warn against believing any part of such reports (Ganaway, 1989; Ofshe, 1993; Putnam, 1991). For their participation in the definitive UCLA study on the effects of ritualistic abuse (Waterman, *et al*, 1993) an award-winning journalist reviled McMartin parents for "enrolling [their children] in the 'research' projects of zealots" (Nathan, 1990; see also Dr. Summit's Introduction, p. ii). In view of such controversy and considering the importance of factual, objective criteria for future

child protective interventions, determining the presence or absence of the alleged tunnels under the McMartin Preschool assumes monumental significance.<sup>1</sup>

The parents, convinced that their children were being unfairly discredited due to a lack of adequate search for the relevant supporting evidence, retained a professional team to resolve these questions regarding the integrity of the children and the truth of their statements. Thus the goals of this project were to objectively search for data bearing on the questions of whether there were subterranean openings (tunnels and /or rooms) under the preschool.

It should be pointed out here that the author was retained to provide an objective and open-minded scientific opinion as to the resolution of the goals of the project. This writer was aware of the case, given the intense media coverage over many years, but he had not formed any opinion as to a preferred verdict. Moreover, given the emphasis of the news media in 1990, he was somewhat skeptical that any corroborative data would be uncovered during the investigation. The author made it clear when he was retained that he would be completely objective in the investigation and that if no data supporting the goals were found then that possible result would be the reported outcome without qualification. However the opposite proved to be true.

Since the circumstances were so extraordinary, this field project was quite difficult to conduct. This was due not only to the constricted time frame allotted to us for the work but also due to the intense interest of the news media (television, radio and newspapers) and the curious crowd of visitors who had to be kept back from our work areas on a daily basis. It is unusual, to say the least, for an archaeological project to be conducted under such a "spotlight", especially such an emotionally charged one, and therefore the management of the project was not easy. But the staff and crew were up to the challenge and they held steadfast to the plan for the exploration of the site.

Many of the references to events and persons relevant to the site, and to the project leading up to the specific archaeological excavation upon which this report is based, are to articles that appeared in various newspapers. It is well known that newspaper articles are fraught with problems of accuracy. These articles were used because other sources documenting the cited events were either too voluminous (many thousands of pages of court transcripts), or were in the form of the children's reports made in confidence to therapists. In every instance, however, the only newspaper accounts that are cited are those which have witnesses to corroborate the accuracy of their statements relevant to this project.

The next section presents more specific background information on the project.

---

<sup>1</sup> Author's note: Jackie McGauley contributed research information to this paragraph.

## 1.2 Background of the Project

The preschool site was located in the greater Los Angeles area of Southern California, in the City of Manhattan Beach. Specifically it was located at 931 Manhattan Beach Blvd. It was built on a rectangular parcel near the northeast corner of the intersection of Manhattan Beach Blvd. and Walnut Ave. (Figure 1). The rectangular lot measured some 35.4 m.(116') N/S by 11.1 m.(36') E/W. In addition we explored the neighboring lot (927 Manhattan Beach Blvd.) which bordered the preschool lot, extending west of it to the intersection of Walnut Avenue and Manhattan Beach Blvd. (see Figure 1). This property, referred to herein as the "side lot", measured about 35.4 m.(ca. 116') N/S and 12.3 m.(ca. 40') E/W (Langenwalter, *et al*, 1985). Thus the combined two lots measured 35.4 m.(116') N/S by 23.4 m.(76') E/W, with a combined total area of 828.4 square meters (8,747 sq. ft.). This area is hereafter referred to as the "site."

As stated in section 1.1 above, the objectives of this archaeological project were to independently and objectively resolve whether or not actual corroborative evidence of the reports of the children regarding features and data at the preschool could be located and recovered. This was necessitated by the fact that despite seven years of official investigation, from September, 1983 to July 27, 1990 (*USA Today*, 1985; Wiley, 1991, p. 88) the tunnel reports of the children and the attendant concerns of the parents were never adequately addressed. The lack of tangible corroborative evidence of the children's reports of subterranean openings was used in court to cast doubt on the credibility of the children's testimony regarding the case in general. Obviously if such corroborative data were to have been discovered and entered into evidence at the appropriate time in the case, they may have been important factors in the jury's final verdicts. However, as the series of events occurred, as described below, no such corroborative evidence was to be forthcoming until our work. Even when it was recovered, it was given no role in the court cases.

Given the distinctive reports of the children and the vital importance of potentially corroborating evidence, it is very surprising to this writer that the McMartin Preschool site was not effectively and properly investigated for such evidence. In order to successfully search for such information two measures should have been implemented:

- 1) The "integrity" of the site should have been preserved by sealing off the site to any access by the defendants or anyone else until the possibility of the reported evidence had been adequately resolved. The purpose, of course, to immediately sealing off the site would be to hopefully "freeze" *in situ* (in original location) any potentially relevant data or evidence bearing on the case so that it could be located and identified when searched for.
- 2) Then competent and qualified investigators should have been called in to conduct a proper and thorough subsurface search for any such data. A logical choice is for the officials to call on archaeological expertise, since the police do not have the depth and range of field experience required to properly search for such buried features. Experienced archaeologists have built up a mental "data bank" of often subtle information on buried features such as post holes, various kinds of pits, house pits, buried passageways (e.g. tunnels or tunnel-like features), etc. and have learned to distinguish them from other buried phenomena such as rodent holes, buried natural erosional channels (buried stream channels) and the like.

FIGURE 1. MAP SHOWING McMARTIN PRE-SCHOOL AND SIDE LOTS

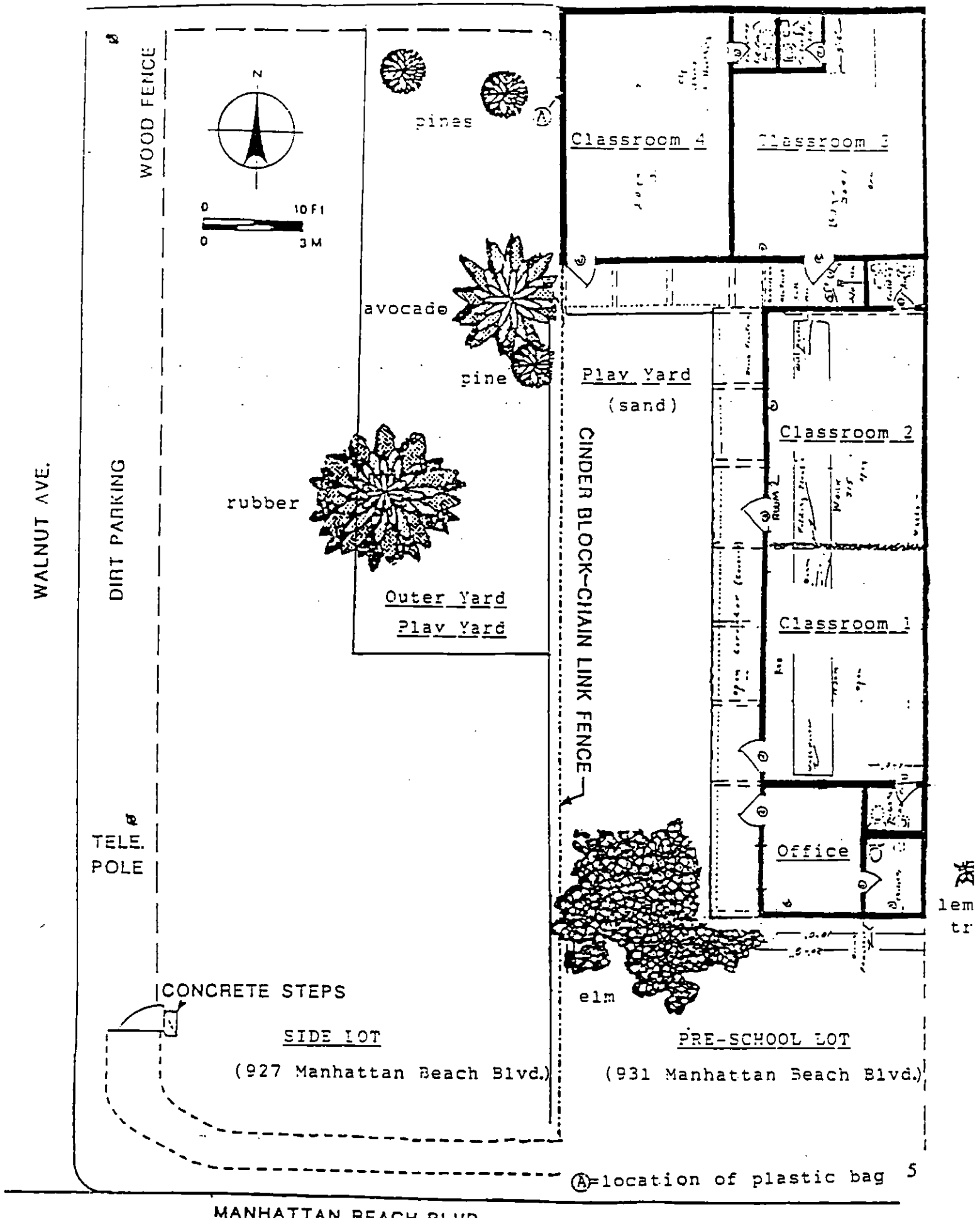

Archaeologists distinguish such buried features (which in some cases allow them to even reconstruct the superstructures of ancient houses in a given culture) through a variety of observed information. This information can be in the forms of differences of soil color, soil chemistry, soil texture and grain size, or the presence of "inclusions." Inclusions can be either natural materials such as pebbles or stones or cultural materials such as burned wooden post fragments or artifacts such as pots or pot fragments contained within former openings (e.g. a storage pit). Such openings are often later completely filled in either intentionally or by natural depositional processes of soil movement (cf. Hole and Heizer, 1973 for a good discussion of such subtle features and Schiffer, 1976 for other theoretical discussions of such processes). All of these data form what archaeologists call "signatures" that allow each buried feature to be recognized and identified. Such signatures for a tunnel and/or buried room are discussed below in section 1.4.

Expertise that was suitably knowledgeable and capable was needed but unfortunately was not properly deployed for a timely and definitive exploration of the site. In fact, given the children's assertions regarding subsurface phenomena, including the burials of small animals purportedly sacrificed, surprisingly it was not the prosecution which initially conducted an excavation but the defense instead. For reasons unknown, the defense decided to explore the site with its own excavation. Mr. Paul Bynum, a former Hermosa Beach Police lieutenant who was hired as a defense investigator (*Easy Reader*, 1987) conducted a dig for evidence at the subject site. The prosecution never questioned the appropriateness of allowing the defense to conduct its own excavation, or why the defense would even want to conduct such an excavation (i.e. if there was no evidence as they argued, then why even look for any?). Even if any relevant data or evidence were to be recovered by their dig, the lack of proper archaeological expertise would preclude proper proveniencing of the data *in situ* in the field and thereby would invalidate its usefulness for scientific purposes.

Bynum apparently conducted his informal digging in February, 1984 (*Daily Breeze*, 1987). It is significant to note he did unearth some buried animal remains of "...numerous pieces of tortoise shells and bones" (*Daily Breeze*, 1987; Langenwalter, 1992a: personal communication). There was keen interest in these data at the time since it was reported that the children "...testified that tortoises, rabbits, and other small animals were mutilated ... (in order) to terrorize the children into keeping silent" (*Daily Breeze*, 1987). Bynum was slated to testify on these data on Thursday, December 10, 1987, but was found shot to death the night before (*Daily Breeze*, 1987). It is not surprising that the defense could dismiss its own gathered data as irrelevant.

It was more than one full year later (and two full years after the criminal investigation had begun), that the parents became "...righteously impatient" (*Daily Breeze*, 1985c; cf. *The Beach Reporter*, 1985) with the lack of a suitable official investigation, and decided to take matters into their own hands by investigating the site themselves. The observation (in about April, 1985) of some unusual construction activity on the side lot, as evidenced by a pile of dumped concrete (McGauley, 1992: personal communication), led to the parents' interests in exploring the site. In addition, on Wednesday March 13, 1985, the parents observed a new feature of a squarish concrete slab, located northeast of the avocado tree and near the southwest corner of classroom #4 (see Figure 1). Although the parents could

not obtain permission to dig on the preschool site lot itself, controlled at the time by an attorney for the defense, they did obtain permission to dig on the side lot from Mr. Arnold Goldstein, owner of that adjacent lot between the preschool and Walnut St. (see Figure 1). The defendants had leased a portion of the side lot as a play yard for the preschoolers (Langenwalter, *et al*, 1985: 3; cf. *The Beach Reporter*, 1985: March 21).

It should be noted that it has been erroneously reported that: "According to Will Abrams ... of the Los Angeles County District Attorney's Office, parents of children involved in the case performed unauthorized excavations on the site" (see Peter in Langenwalter, *et al*, 1985: 6). The parents did notify the District Attorney's Office of their intent to explore the side lot site and despite an invitation to join in the effort, the D.A.'s Office declined involvement (Currie, 1992: personal communication). Unleashing their collective pent up frustration, some 50 parents descended on the adjacent play yard lot. Under the general leadership of Robert Currie (a parent), based on directions from some of their children, parents began unsystematically digging on Saturday March 16, 1985 (*Daily Breeze*, 1985b; Currie, 1992: personal communication). They could find nothing under the mysterious concrete slab, so its purpose remained unknown.

However, they pushed on:

Using a backhoe, they (the parents) began Saturday (i.e. March 16, 1985) morning by looking for a tunnel and an underground 'secret room' that have been described in testimony during the lengthy preliminary hearing. Although they found no tunnels during that search, they later uncovered another apparent tortoise skeleton and some bone fragments using shovels (*Daily Breeze*, 1985c).

The parents were also looking for evidence relative to statements made by some of the children that "...rabbits, turtles and birds were slaughtered at the school ... to terrify molested youngsters into silence" (*Daily Breeze*, 1985d).

The parents were also motivated by their discovery of "...an old city permit issued to McMartin authorizing the removal of 80 cubic yards of earth" (*Daily News*, 1985) which they thought to be an indication of the excavation of a tunnel at the site.

Employing a backhoe and shovels, parents dug haphazardly in a number of places in the lot without any success. Then, after the backhoe crew left:

Parents began to dig with shovels, allegedly in an area pointed out by a nine-year-old former student of the McMartin preschool, who told them to dig behind a cement planter in the northeast corner. When parents unearthed several broken turtle shells and a few bones, they stopped digging and notified the district attorney's office. A police line was set up around the lot at 8:30 [p.m.], Saturday evening [March 16, 1985]. (*The Beach Reporter*, 1985; see Figure 3 for parents' tortoise location)

The parents were elated that they had found some evidence seemingly relevant to the case and proving that their children's reports were true. After the excavations by both the defense and the parents (both of whom found data potentially relevant to the case), the District Attorney's Office finally considered it appropriate and relevant to conduct an excavation to search for evidence. Thus the parents were successful in prodding the District Attorney's Office into sealing off the area and conducting an official subsurface



search at the site (*Daily Breeze*, 1985c). Deputy D.A. Roger Gunson apparently promised the parents that "...experts' would be brought in to continue the excavation. What kind of experts, however, he would not divulge" (*Daily Breeze*, 1985c). Glenn Stevens, a prosecutor stated "...[it was] unwise for anyone without a forensic background to conduct such a search" (*Daily Breeze*, 1985d). The "excavation" was further delayed a week (*Daily Breeze*, 1985c).

The District Attorney's Office then hired a local archaeological company, Scientific Resource Surveys (S.R.S) to conduct a search for evidence using archaeological techniques (Langenwaller 1992a: personal communication; Langenwaller, *et al.* 1985). The project was co-directed by Nancy Desautels, Ph.D. and Paul Langenwaller, M.A. who conducted the project in cooperation with members of the Sheriff's Crime Lab (see Figure 2). (*The Beach Reporter*, 1985) The D.A.'s Office restricted the excavation to the area of the McMartin play yard in the Goldstein lot. The excavations focused on the area of the parents' excavations searching for an entrance to an underground room (at the northeastern corner of the side lot property) and along the eastern property boundary. No other excavations were allowed by the D.A.'s Office (Langenwaller 1992b: personal communication). Consequently an archaeological project was conducted for only two weeks (from March 20 to April 8, 1985; Langenwaller, *et al.* 1985: 1). The specific goals of the project were to: "(1) . . . determine if the property contained the buried remains of animals exhibiting the effects of traumatic death: and (2) determine if the property contained evidence of a subterranean room" (Langenwaller, *et al.* 1985: 1).

Initially some remote sensing equipment in the form of a terrain conductivity meter was deployed to search for the "room" both inside the preschool lot and in the adjacent side lot owned at the time by Goldstein (Langenwaller, *et al.* 1985: 12-13, 19-21 and Appendix A. Robert Beer: cf. *Daily Breeze*, 1985c). The survey was conducted by Mr. Robert Beer, a respected geophysicist, using a Geonics EM-31 electromagnetic geophysical survey instrument. "The basic principle of the technique involves the use of a primary magnetic field to induce eddy currents into the subsurface soils. The resultant secondary magnetic field is measured and evaluated in terms of (electrical) conductivity." (Langenwaller, *et al.* 1985: Robert Beer Appendix A: 1-2). In this fashion, "anomalies" to the basic electromagnetic field pattern for the properties were searched for to locate the reported "room". This remote sensing survey was not conducted to search for underground openings beneath the preschool itself but "...were obtained within a limited area on the McMartin Preschool property, primarily in the west and south play yards. . . . The close proximity of buildings, fences, and permanent metal fixtures precluded additional work in these areas." (see Beer in Langenwaller, *et al.* 1985, Appendix A: 1). No anomalies were detected there. The geophysical data were apparently so problematic that no data maps were generated for the preschool site. Numerous material items and features interfered with the instrument's ability to obtain useful results. Hence a decision was made at that time to concentrate on the side lot. The entire lot was surveyed and recorded based on a 2 meter grid system (See Figure 3). With usable data, two maps were drawn showing the resultant instrument recordings (Langenwaller, *et al.* 1985: Figure 6, p. 20).



FIGURE 2: DISTRICT ATTORNEY'S ARCHAEOLOGICAL DIG OF 1985  
(Note area shown is just west of Classroom 4)

FIGURE 3: DISTRICT ATTORNEY'S 1985 ARCHAEOLOGICAL REMOTE SENSING SURVEY MAP OF THE SIDE LOT WITH ELECTRONIC READINGS (Note: Anomalies Indicated)

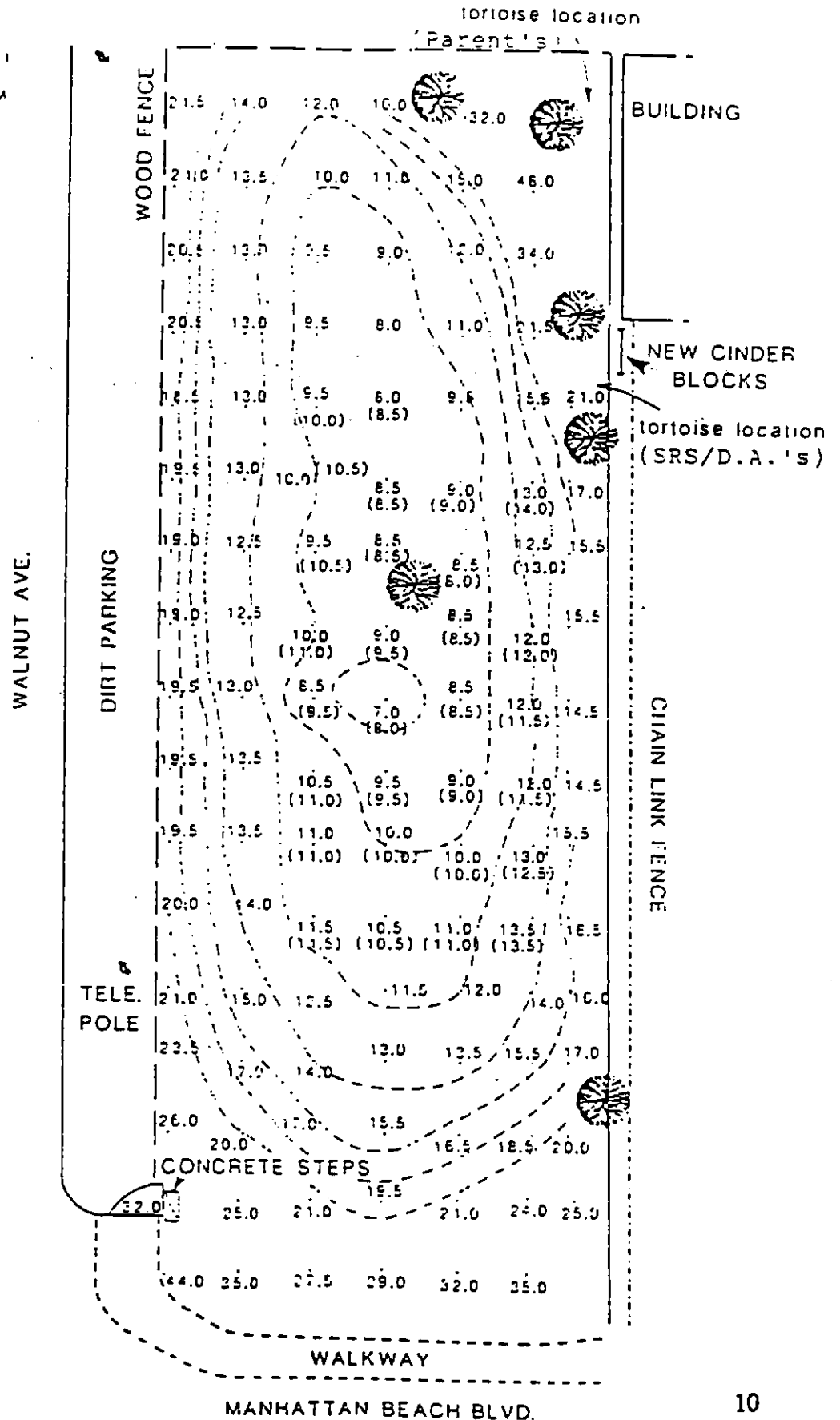
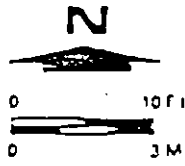

With better data, two anomalies were detected in the side lot by the geophysical survey (see Figure 3). These were:

... (a) curving linear anomaly near the middle of the lot, adjacent to the south and southwest sides of the large rubber tree. ... this anomaly lay at a depth of 3.6 m. (ca. 10-19.5'). There was no clear indication of how the anomaly should be interpreted. A second anomaly was found at the eastern edge of the lot next to the McMartin Preschool fence in the vicinity of the large bush, an area where some witnesses alleged that animals had been buried. (This was interpreted as) ... a probable indication of slightly altered ground conditions, but (the geophysicists) could not offer a more detailed explanation (Langenwaller, *et al*, 1985: 19-21).

Despite these indicative findings and the recommendations of the archaeologists to excavate and identify the anomalies, the District Attorney's Office did not pursue these possibilities (Langenwaller, 1992b: personal communication). Consequently "The anomalies targeted by the terrain conductivity meter were not excavated and, therefore, their exact nature remains unknown" (Langenwaller, *et al*, 1985: 19).

The D.A.'s office used the conductivity meter in the preschool with negative results. They also peeled off some of the floor tiles looking in vain for any indication of an entrance to possible tunnels (McGauley, 1992). The District Attorney's Office made a decision not to explore under the preschool building itself even though this was where the children reported both entrances to the tunnels as well as the tunnels and possibly the presence of the room or rooms (*Daily Breeze*, 1986a, b, 1989; *Easy Reader*, 1988; cf. Appendix II). However, the terrain conductivity meter was not the appropriate instrument to search under the existing school, as proven by its problematic results. Therefore a recommendation to use a more appropriate instrument that could have yielded useful results (e.g. Ground Penetrating Radar) should have been made and implemented. Nevertheless, citing financial and time constraints, the D.A.'s Office decided to limit both the effective remote sensing search and the formal archaeological excavations to the side lot. Thus the archaeologists were put in the position of not being allowed to search in the primary lot (the McMartin Preschool lot *per se*), were not allowed to excavate and identify the two anomalies detected by their own project's remote sensing survey, and were even restricted in where they could dig within the side lot itself.

Next the archaeologists took the grid system (that was utilized for the remote sensing survey) and laid out 7 units, excavating 6 (Figure 4). They completed the digging of all 6 units using standard archaeological methods, although the "...application of [the] techniques was more thorough than in most excavations...to assure [an] accurate and thorough recovery of all possible evidence" (Langenwaller, 1992b: personal communication). All six excavated units were confined to the "northeastern quarter of the site", and despite the location of the remote sensing detected anomalies, "As requested by the District Attorney's Office, SRS restricted excavation to the area previously encompassed by the enclosure." The "enclosure" was a rectangular area about 19 m (ca. 62') N/S by 6 m (ca. 19.7') E/W which had been enclosed by a 6 foot high opaque fence made of dark green painted plywood panels supported on metal posts (see Figure 1). This area had been leased by the preschool as an additional play yard and animal pen (Langenwaller, *et al*, 1985: 3).

FIGURE 4: DISTRICT ATTORNEY'S ARCHAEOLOGICAL EXCAVATIONS SHOWING UNITS Note units clustered in NE sector of side lot off room 41

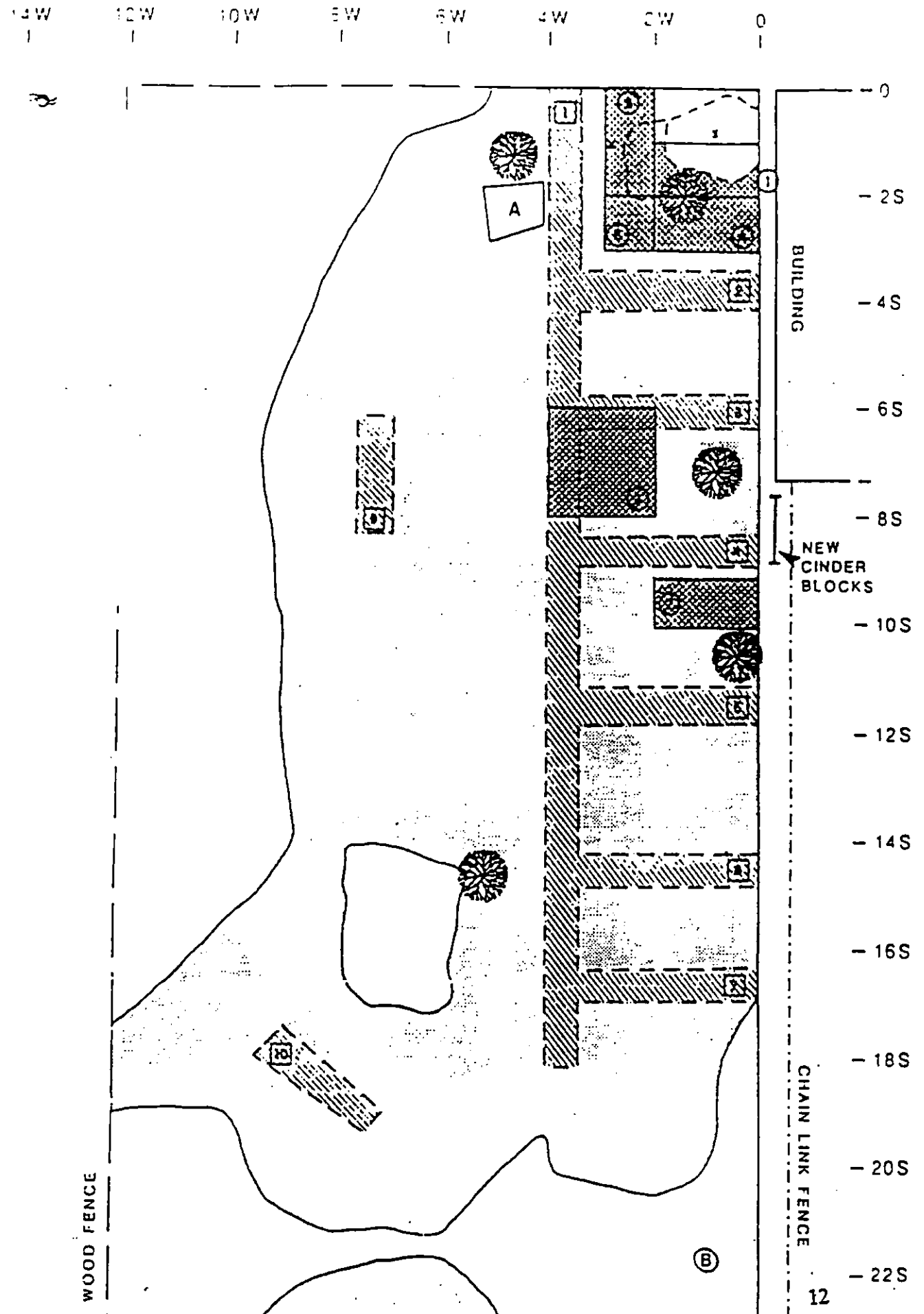

Units 1, 4, 5 (all 1 x 2 m. in size) and 6 (1 x 1 m.) were excavated in the northeastern most part of the lot, immediately adjacent to the west wall of classroom #4 (See Figure 4). Unit 2 (1 x 2 m.) was not excavated. Unit 3 (a 2 x 2 m. unit) was located some 3 m. slightly to the southwest and was placed because "... an entrance [to a tunnel leading to a room] was supposed to be (in the area where Unit 3 was placed" (Langenwaller, 1992b personal communication, see Figure 4 for the location of Unit 3). Also, it should be noted that they dug in that location because "...the area [was also] identified by several children [personal communication, District Attorney's Office] as containing a subterranean room" (see Peter, in Langenwaller, *et al*, 1985: 13). Unit 7 (1 x 2 m) was dug along the preschool play yard fence "Based on the knowledge that people tend to bury animals near to fences, walls, or property boundaries" (see Peter, in Langenwaller, *et al*, 1985: 13).

In the search for a buried "room", the archaeologists dug down each pit until they encountered either "...1) soil not disturbed for a considerable length of time...or 2) disturbed soils from backhoe trenches excavated by the parents..."(Langenwaller, *et al*, 1985: 21). Such undisturbed soils were reached at depths of 40-60 cm. (16-24"), which led the archaeologists to conclude that no subterranean feature (i.e. a room) had been detected by their work.

The second goal of their project was addressed by careful excavation downward, looking for any animal bones and/or skeletons. The results of the excavations yielded the following. Six units in the side lot "...yielded several thousand pieces of cultural debris. These included ceramic, shell, and plant remains." Much of the material was found in the clustered units 1, 4, 5, and 6. This data was referred to as a "trash scatter". "The trash scatter contained a mix of bottles, ceramics, tin cans, burned wood and bone"(Langenwaller *et al*, 1985: 21). This trash scatter was dated in the report to "... sometime in the 1930's", however some of the "...items, in particular those composed of paper and plastic, were accumulated in the past several years" (i.e. prior to 1985; (Langenwaller, *et al*, 1985: 22).

Some "700 bones" were excavated and analyzed as part of the work. Special discussion was devoted in the report to a portion of the bones. These were specifically the bones of a tortoise that had been dug up by the parents in the northeast corner of the lot (see Figure 3). Analysis disclosed that "There is a break in the plastron (underside of the shell) of the tortoise found by the parents which, upon close examination, might prove to be impact trauma from some type of tool"(Langenwaller, *et al*, 1985: 30). Langenwaller (personal communication, 1993) has re-examined the specimen and no longer concludes that the break indicates a traumatic death. The archaeologists then found their own tortoise which was found *in situ* and undisturbed in Unit 7 (Figures 3 and 4). This was designated as Feature 1 and was given considerable attention in the report. Unlike the tortoise found by the parents, the Feature 1 tortoise was found intact and had a complete and unbroken skeleton. Analysis showed no evidence of trauma. Also observed: "A drop of red paint was on one dermal scute (bony plate) located above the left hind limb. The orange paint (that had been noted previously on 12 of the dermal scutes) formed some sort of design on tortoise's back" (Langenwaller, *et al*, 1985: 28).

In sum, it was concluded that the Crime Lab/SRS excavations did not yield any data relevant or useful to the case. In the instance of what was considered to be the two most relevant pieces of information. "...the tortoises are not strong sources of evidence" (Langenwarter, *et al.* 1985: 31).

It should be noted too that all historic data (artifacts, bones, etc.) were treated as "evidence", inventoried, and bagged with provenience, then placed in "evidence boxes following police manner". According to the principal author of the report, "No cataloguing was done in an effort to maintain the chain of custody"(Langenwarter, 1992b: personal communication). Thus the data were not catalogued in the standard scientific archaeological manner. All the data were then removed from the site and put in D.A. custody and stored in an "evidence locker" (Langenwarter, 1992a: personal communication). The District Attorney's Office then terminated the work.

Thus, despite the recommendations made by the archaeologists to further excavate and explore the anomalies (in fact, the archaeologists also made a recommendation to utilize another remote sensing technique, Ground Penetrating Radar, G.P.R.), the District Attorney's Office rejected all recommendations and the archaeological exploration ceased (Langenwarter, *et al.* 1985; Langenwarter, 1992a: personal communication). The archaeologists were not satisfied with the restricted project and would have preferred to further explore the site. Following the D.A.'s instructions, the results of the project were then written up into an archaeological report (Langenwarter, *et al.* 1985) and submitted to the D.A.'s Office. All artifacts and data (including notes and photographs) were taken by the District Attorney's Office, which continues to store the materials (Langenwarter, 1992: personal communication).

Langenwarter, and other researchers included his observations in the resultant report (Langenwarter, *et al.* 1985). He also discussed them on the witness stand during the first trial in 1989 (Langenwarter, 1992a: personal communication).

In addition, Langenwarter was also asked by the D.A.'s Office specifically to do a separate study to examine the tortoise bones that had been dug up by the defense's private investigator Bynum. His examination was in a highly controlled room situation with the bailiff, the D.A.'s investigator, the defense's investigator and the defense's veterinary pathologist all present. Langenwarter found no traumatic death indicated in the bone material he was given. However the material did not represent the entire animal's skeleton (as was the case with the parent-discovered tortoise). Because of collecting techniques used by Bynum, Langenwarter did not generate a report on his observations but he did take "detailed notes" (Langenwarter 1992b: personal communication).

Given the ambiguous investigations, the findings were easily discounted:

Defense attorneys disagree (with the claimed supporting evidence of the bones and shell pieces), mentioning the possibility of the items having been planted by the parents or of neighborhood children having used the lot to bury dead peis (*The Beach Reporter*, 1985).

The effort on the part of the parents thus did not resolve the questions which, unfortunately might have been answered had the measures stated above been properly implemented.

At that time (March, 1985) the D.A. obtained a search warrant and brought a number of families and their children, including Jackie McGauley and her child, to the preschool to search for a tunnel entrance (McGauley, 1992: personal communication).

The preschool was cordoned off by a police line only in March, 1985), over one and one half years after the investigation had officially begun. The police line was only in effect for the two weeks of the archaeological dig and purported "forensic studies" (searching for human and animal body fluids such as blood, semen and urine remains, etc.). Despite the reports of the children, investigators did not explore for the tunnel and room features, under the school itself, the very place where the children insisted the tunnels could be found.

Consequently, the defendants had full access to the property for quite a span of time prior to the short sealed-off period. They again regained access for years (over 5 years) afterwards until the present project was implemented in 1990. These conditions hardly constitute an objective situation in which to resolve whether the reported evidence was present or not in an undisturbed context.

The preschool site itself was searched by the authorities with search warrants three times: September 7, 1983; March 6, 1984; and April 10, 1984 (*Daily Breeze*, 1984b). The evidence that was obtained at those times was not made public.

A fire occurred at the preschool on Sunday, April 8, 1984 and was reported to the fire department at 11:38 p.m. It was reported that an arsonist threw an inflammatory object through a window in Classroom #2. An estimated \$10,000. damage was caused to the preschool (*Daily Breeze*, 1984a), which specifically resulted in two "gutted classrooms" (*Daily Breeze*, 1984c). The preschool was later rebuilt, eradicating virtually all damage caused by the fire, in order to present an unsullied appearance for inspection by the jury.

Thus this project was implemented after the prolonged and confused period of disturbance of the subject site on the two adjacent lots. These complications were kept in mind during our exploration of the site.

### 1.3 Preliminary Investigations on the Present Project

A chance to finally resolve the outstanding questions came when Goldstein who owned the adjacent parcel (the "side lot" which had been leased by the defendants and used as a play yard for the preschoolers), purchased the lot containing the preschool itself from attorney Danny Davis (see Figure 1 for the location of these two lots). Some of the parents then obtained access to the preschool site itself and for 2 days actually dug on their own in the northeast corner of classroom #3. This occurred on Saturday, April 21, 1990. A meeting of the parents was held that night to address the importance of properly investigating the site and having the work conducted by objective professionals.



The work of the previous day was reviewed on April 22 by Ted Gunderson, a Senior Special Agent in Charge of the F.B.I., Los Angeles Division, visited the site on April 22, 1990. He explored the hole that was dug in the Classroom #3 (see Figure 11, Unit 2). In it he found some charcoal, wood chips with green paint, glass fragments, fragments of concrete, a piece of a ceramic plate, floor tile fragments, and yellow and red ribbons. But because the parents had dug the hole without professional supervision, there was no assurance of the *in situ* provenience of these finds.

Jackie McGauley, one of the parents, then decided to implement a project to investigate the school site by professionals and resolve the questions in a definitive manner. Mr. Gunderson, taking the role of Project Coordinator, approached Goldstein for permission to conduct the project and he kindly agreed, noting that Gunderson was a licensed Private Investigator, on the condition that he would assume full responsibility and liability for the care and security of the subject property. Correspondingly a formal contract was signed by both parties on April 25, 1990.

Since Goldstein gave the project essentially only until May 10, 1990 to complete all on-site investigations, the project began the next day, on April 26, 1990. The first day was spent cleaning up the site and emptying the classrooms to facilitate the exploration. Ms. McGauley had earlier retained Dr. Don Michael, a geologist and Mr. Jerry Hobbs, a professional mineral miner and prospector with international experience. Hobbs was specifically retained to explore for the tunnels and to insure the safety of all excavations, drawing on his mining experience. Dr. Michael was retained to help search for tunnels due to his experience in distinguishing between natural and unnaturally deposited soils and in other geological characterization of the deposits on site. Tom Reddin Security, Inc. was hired to protect the property during the project.

In the earlier, unsupervised excavation, some of the parents had dug down to 15 feet in the hole in the northeast corner of Classroom #3 (see Figure 11, Unit 2) looking for an entrance to a tunnel (some children had mentioned an entrance for a tunnel in that general area, but not precisely in that corner). They were not successful in finding an entrance. However, due to their lack of qualifications and experience, any possible entrance to a tunnel could have been obscured by haphazard digging. That hole was about 3 x 3 feet square at the surface, expanding to 4.5' x 4.5' at its widest point at 82" deep (6' 10").

Jerry Hobbs entered the parents' dig in Classroom #3 (our Unit 2) and further explored and dug down some 26 inches deeper and sifted all the soil removed. Hobbs (1990) took formal notes on the work. He dug up some large roots and some broken, 10" long, deteriorated, upright wood fragments (possibly from 4 x 4's) that were found at a depth of 90" below the concrete pad floor. He also recovered a prehistoric Native American chert scraper (Catalog MP439A). These finds were made below the level of the previous excavation by the parents.

Other historic artifacts found in that work included a brass brad, a shard of glass (at 96"), a small white button of the type common for a man's shirt (at 100" depth), and a charred piece of wood (it was speculated that it may have been from the fire that had occurred at the school on April 8, 1984, Daily Breeze, 1984a) and flecks of green paint the

~~same color as the shelving on the wall of the classroom above the hole.~~ Gunderson collected and retained these data and gave them his own numbering system (they are included in the general project catalogue, i.e. TLG#101). Hobbs also dug out from the main hole at a depth of 72", digging laterally two feet in several directions. He determined no patterning.

Hobbs also dug in the "side lot", (see Figure 1) and dug around an avocado tree next to Classroom #4, where he detected some prior digging disturbance. No relevant patterning could be detected (See Appendix III.2).

Dr. Michael came to the site on April 27 to conduct his initial geological investigation. He also examined the hole next to classroom #4. He took soil samples from the hole and later reported no indications of data that would warrant further research.

On April 30, 1900, Superior Concrete Co. cut through the concrete slab floor with power saws and cut out small samples of the floor from Classrooms #3 and #4. These samples were cut in order to try to ascertain the age of the concrete flooring, to test the possibility that the floor had been removed, tunnels excavated or filled, and then new flooring put in. A concrete expert determined that such information could not be obtained, so that approach was abandoned.

Jerry Hobbs arrived on April 30, 1990 with a metal detector in an attempt to find a "void" in the ground (i.e. possible tunnel openings). His findings with it were inconclusive. Then he continued the excavation around the tree which he had begun on April 26.

Various work and note taking were made until May 2, when work commenced with a backhoe. One trench was dug directly alongside the west wall of Classroom #4. A decision was made to explore this precise area because some of the children had stated that there had been animal cages placed along that wall and that they had entered a tunnel under the cages at that point (cf. Langenwalter, *et al*, 1985: 13). The backhoe dug a trench two feet wide and 8 feet down along the entire west wall of Classroom #4. Gunderson and Hobbs then observed a plastic bag fragment protruding from the soil deposit under the foundation (some 26" below the foundation, 42" below the surface, 124" from the northwest corner of the building, and 3-6" inside the wall line of the building (see Figure 1 for the map location of the bag and Figure 5 for a photograph of the bag in its *in situ* location).

Leaving the bag *in situ*, Hobbs then probed some 10-16" below the foundation (at 128" south of the northwest corner of the building) and above the bag and uncovered more objects, which included some bones, rusted cans, bottles (both whole and fragmented) that appeared to date to the 1940's or older, a nozzle, parts of a rubber hose, and small pieces of asbestos sheets. These objects were plentiful and appeared to represent a dump site. These items were collected and marked with the TLG numbering system. When the soil had dried out somewhat, a feature of disturbed soil was noted which was "half moon shaped" and was measured as follows: at the bottom, 44" below the foundation where the soil became more compact, it was 56" wide and 91" wide at the top; (cf. Figure 18a).

The above-mentioned plastic bag was then photographed *in situ* (see Figure 5). Hobbs then excavated some 6" below the debris of cans, bottles, etc., and removed the plastic bag noted above that had been exposed by the backhoe (it was bagged and numbered).

The recovered plastic bag (artifact catalogue No. MP 1) was then closely observed. It was in a fragmented state (especially shredded on three sides) but enough was preserved to measure it at about 15.2 cm. (6") wide by 19.0 cm.(7.5") long. Ms. McGauley believes it to have been a fold lock type sandwich bag (McGauley 1992: personal communication). The bag had three missing sections. On its preserved parts, the bag had a variety of Walt Disney characters (Mickey and Minnie Mouse, Donald Duck and Daisy Duck, Goofy, and Pluto) and a "copyright 1982 Walt Disney Productions" printed on it, along with a logo of a school house with "Disney Class of 1982/1983" underneath (Figure 6). This find (which was later catalogued by the archaeology team with no. "MP 1") appeared significant because it was 15.2 cm.(6") below other objects which were much older in origin. Geologist Michael was then called in to examine the find area. He made certain observations which are discussed in Section 5.3 (see Figure 18a, drawing by Dr. Michael).

Next, they noted two large cut-off avocado tree roots (labeled "TLG #316"; both about 1.5" to 2" in diameter). The two large cut-off roots were located 14.5" and 12.5" below the foundation (30.5" and 28.5" below the ground surface) and 128" from the northwest corner of the building and 16.5" and 14.5" respectively inside the wall line of the building. These roots (Figure 7a and 7b) bordered the area containing the debris of bottles, cans, etc. It was apparent that had the roots not been cut, they would have extended through the area containing the cans and bottles. These two roots were still alive. However 59" to the north on the same axis were the remains of another avocado root (dead) which appeared to be an extension of one of the two living roots on the opposite side of the gap. This nonliving root segment was found some 9" (23 cm.) inside the wall line of the classroom and 21" below the foundation (37" below the ground surface. See Figure 19).

Jerry Hobbs, who has 25 years experience as a professional tree surgeon, noted that all of the cut roots across the area below the foundation of the west wall of Classroom #4 were from an avocado tree that was still standing near the southwest corner of the west wing of the preschool (see Figure 1). He estimated the tree to be about 25-30 years old, with at least 25 years in its present location. This he determined by the size of the tree, the tree rings in its trunk, and its established root system. Observing one of its main roots, he noted that it had been severed with a hand saw about 90% through, after which it had been pulled off, peeling back and exposing the bark of the root in the process. He also noted that the cambium layer of the peeled part exhibited well-established healing in process. New feeder roots, 15 inches long, had started to grow from that portion of the root as well. These factors indicated to Hobbs that the root had been cut some 4-6 years earlier (Appendix III). Hobbs observed that the isolated, northward root was dry at the time of his observation (caused by being disconnected from the main, southward root from which it had been severed). the dead end of the root had not started to rot, but the



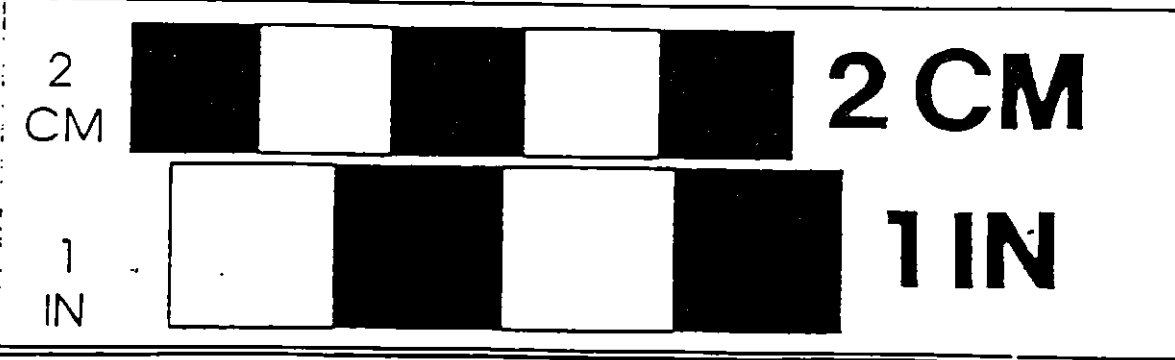
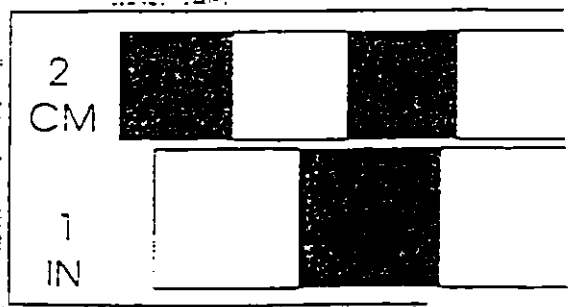



FIGURE 7a: ENDS OF THE SAME ROOTS OF *Ta* SHOWING HEADED END CUTS

FIGURE 7b: ENDS OF THE SAME ROOTS OF *Ta* SHOWING HEADED END CUTS



dried and cracked bark had separated from the root wood by about an 1/8", which indicated to Hobbs that it represented a four to six year old cut, consistent with the time the parent root would have been severed. (Appendix III).

Jerry Hobbs recorded in his notes the following observations:

To me this is conclusive that with the inconsistent soil area, the plastic bag dating 1982 and the old bottles, cans debris, were put in the ground after 1982, and it was not an old dump area as it appeared (Hobbs, 1990; Appendix III).

Hobbs also recorded in his notes that the "destination" of the disturbed soil under the building be further explored, which was later accomplished.

Further digging was conducted at the west wall of Classroom #4 to a depth of 44" below the foundation and underneath the foundation into the debris area. A number of artifacts were recovered, including 2 beads, a shell casing, bones, a clothing snap, bottles, spanish roof tiles, what appeared to be a small man-made fire pit (18" below the foundation and 18" inside of the wall line), two isolated sections of a cut root (labeled as TLG #307, which was seen 35" deep, 27" inside the wall line and 122" from northwest corner of the building, and TLG #316, which was 30" deep, 32" inside the wall line and 128" from the northwest corner of the building.), tar paper, aluminum foil, charcoal, glass fragments, wood and bark fragments, a knife blade, an electrical fuse, egg shell fragments, and porcelain fragments. These were all bagged and numbered with the TLG system.

Noting the dead root section and its relation to the *in situ* roots, Hobbs formed an opinion, and stated in his notes that "The dead and live roots, shows a pattern of entry." He further stated:

The process of following these objects and the soft soil is leading north and south along the inside of the foundation which leads me to believe at this time that there is a pattern and possibly a tunnel. I am convinced that this debris has been put in the area as fill for an earlier hole in the last eight years not a fill from long ago such as the age of the objects appeared in the beginning of the excavation [at that location]. (Hobbs, 1990; cf. Appendix III)

Samples of charcoal were collected from the fire place feature (sample nos. TLG 223, 227) and were taken to Prof. Rainer Berger at the UCLA Isotope Laboratory for radiocarbon dating. The results of that analysis are discussed in Section 5.2. The report is presented in Appendix I.2.

On May 7, Gunderson and Hobbs numbered the four Classrooms Nos. 1-4 (see Figures 1 and 11). A newspaper found wrapped around the toilet waste pipe of bathroom No. 2 was dated June 11, 1987.

At that point Ms. McGauley prevailed in her view that a professional, credentialed and highly experienced archaeologist was needed to provide both an objective search for the data and a careful, scientific and systematic approach to recovering the excavated data, especially since a variety of artifacts and subtle previous excavated features were being found. An inquiry was made to Prof. Rainer Berger, then Chairman of the

interdisciplinary Program of the Archaeology Department at UCLA. Prof. Berger recommended Dr. E. Gary Stickel. Dr. Stickel visited the site and was retained by on May 6, 1990.

Dr. Stickel next retained Crew Chief Don Flaherty and a crew and geared up for the field project by assembling equipment, data recordation forms and materials. The formal archaeological excavation, under Dr. Stickel's direction, began on Tuesday, May 8, 1990.

On May 10, a Superior Concrete Company crew equipped with power saws cut out ten sections of the concrete pad floor throughout the school. These were later examined by concrete experts who advised that it was not possible to age date these sections.

Mr. Jeff Hellman, of G.S.E. Communications Inc. (a professional company for alarm systems), came to the site. On May 11, for the purpose of tracing the wiring connected to what was labeled as the "fire alarm" (see Appendix I: 6).

The excavations conducted by Dr. Stickel's archaeological team (ERA, Environmental Research Archaeologists: a Scientific Consortium) for this project were conducted from the 8th to the 31st of May, 1990 (with 24 days of constant field work respectively). The conduct of the formal archaeological excavation and exploration project is discussed in section 3.0 below.

#### **1.4 Project Research Design, Objectives and Methodology**

All archaeological investigatory research should be conducted on the basis of a research design or a specified plan for scientific analysis based on excavated data that includes the theoretical basis, the hypotheses to be tested, specification of the required data to test the hypotheses, the methods and techniques to be used to test the data, and, given the results of the analysis, how the interpretations of the hypothesis(es) are to be made. The research design justifies the excavation of the data and provides for meaningful results based on the analysis of the recovered data.

Research designs have been asserted as being a requirement of archaeology for some time (e.g. Binford, 1964). The author has also asserted the need for research designs (Stickel and Chartkoff, 1973), and has published an example of one based on a site at Redondo Beach, (Stickel, 1983). It is beyond the scope of this project to provide a detailed discourse on research design development. Interested readers can avail themselves of the process and required elements by reviewing the author's published example (Stickel, 1983) as well as Watson, Leblanc and Redman, 1984.

Relative to the theoretical basis for this project, the author has published a general model of a cultural or human system which maintains that many aspects of human behavior, including past psychological behavior, can be understood by the effective modeling and testing of suitable hypotheses (Stickel, 1982).



One critical aspect of archaeological research is the proper testing of hypotheses. The author has published a model for testing archaeological propositions (hypotheses) (Stickel and Chartkoff, 1973). The author's more recently published research design stresses the use of a multiple hypotheses testing procedure which can attain the best results (Watson, Le Blanc, and Redman, 1984, Stickel 1983, Figure 11.1) Elements of that testing format were considered in all interpretations of the data made in this report.

The primary hypothesis to be tested in our work involved the research problem of whether or not there were a tunnel(s) and an underground room(s) at the site in question. A "tunnel" is defined in Webster's New Collegiate Dictionary as: "1: a hollow conduit or recess: tube, well. 2 a: a covered passageway; specifically: a horizontal passageway through or under an obstruction; 2 b: a subterranean gallery (as in a mine)." Parts 2, a and b formed the working definition of a tunnel that was considered for this research. To clarify this, a tunnel, for our investigative purposes, would be an underground feature that would connect to the surface of the site and extend underground for some distance, possibly (but not necessarily) connecting to an underground room(s).

Because the tunnel in question was reportedly used by humans (both adults and children), it would have to have dimensions large enough to accommodate adult human movement through it. Such a tunnel on the subject property could have been constructed two ways: 1) either dug out as a trench-like opening which would then be roofed over with wood and/or other materials and covered over with fill above to make a true tunnel (as opposed to an open trench), or 2) would be dug out completely underground which would then leave a "ceiling" over its passageway formed of the naturally deposited soil. If the latter were the case, such a tunnel may or may not have been fitted with an underground "roof" of wood and/or other materials either to reinforce the strength of the "ceiling" of the tunnel or to keep loose soil and dust from falling down on people using it. In either scenario (1 or 2) such a tunnel may have had posts of wood and/or other materials (e.g. iron) to serve as shoring reinforcements and as a support system.

Thus given the operational definition of a tunnel considered here, the following hypothesis and test expectations were considered (test expectations are specific, tangible data that are to be expected and are discoverable if the hypothesis is valid; Stickel, 1979).

If a tunnel(s) were present at the McMartin Preschool site, then the following test expectations should be present:

1. An opening(s) (entrance and/or exit) large enough for human passage should be present permitting access from the surface down into a tunnel feature.
2. Tunnel architecture should be linear or curvilinear (i.e. an elongated passageway leading in a definable direction(s)).
3. Tunnel architecture (especially depth or height and width) should be large enough to accommodate adult human passage.

4. The walls and/or uncovered soil ceiling of the tunnel should have "signatures" of markings indicating whether the tunnel had been dug by hand and/or by a machine (e.g. a backhoe).
5. There should be a compacted dirt floor (compacted by human foot traffic) distinguishable from surrounding non-tunnel soil which should not be compacted.
6. The tunnel could be open (i.e. traversable and unfilled).
7. The tunnel may be naturally (i.e. natural processes of erosion and soil redeposition) or artificially (by human action) filled in with soil. Such fill should be distinguishable from the natural soil matrix of the site in terms of color and/or by texture, and compaction (i.e. would be less compact than the soil forming the tunnel's walls, floor and ceiling).
8. Tunnel fill may have inclusions of:
  - A) Natural stones and/or other natural items or;
  - B) Artifacts and/or ecofacts (e.g.: butchered animal bones).
9. Although a tunnel of the type sought in this project may not be directly datable (e.g. in contrast to a construction date molded into the concrete of a railroad tunnel), the tunnel may be dated indirectly by the dates on artifacts contained within it if any are present.

The test expectations for a subterranean room would be essentially the same as for a tunnel. The exception would be for test expectations 1, 2 and 3 above which would be modified to reflect necessary doorway(s) into a room, that the shape of the room would not be too linear (as a tunnel) but would be "room shaped", i.e. square, round, or ovoid, and that a room would be of sufficient dimensions (length, width and height) to be distinguishable from a tunnel passageway. A room would thus be of sufficient size to accommodate a number of people interacting in a face-to-face manner as opposed to a tunnel which (depending on its size) would provide restricted possibilities for human interaction. Since, on balance, one would expect human usage of a room to be more prolonged than in a tunnel passageway, artifacts catering to prolonged usage would be expected in such a room, perhaps in the form of chairs, couches, tables, a lighting system, etc. These expectations were borne in mind during our search of the site.

One aspect of the search for the data of the test expectations relative to the hypotheses, was the use of remote sensing instrumentation. As pointed out in Section 1.2 above, the District Attorney's Office utilized one type of such an instrument, the terrain conductivity meter, in their search for subterranean openings (Langenwalter, *et al*, 1985; cf. Hester, Heizer and Graham, 1975: 21-22). The author is familiar with the usage of such equipment and has utilized various kinds of remote sensing instruments on many projects. For example, the author and a colleague have recently published the most extensive underwater remote sensing survey (which utilized multiple types of instruments) ever conducted in European Archaeology (Stickel and Garrison, 1988). Based on this experience, the author maintained that the best remote sensing equipment to search the

subject site was Ground Penetrating Radar. Its use and effectiveness is discussed in Section 5.7 below. Also the project Geologist, Dr. Michael, conducted a short electrical resistivity survey at the site (see Section 5.3: Appendix I.3).

## 2.0 Project Background

### 2.1 History of the Project Parcels

The two lots that were investigated for the project are located within the City of Manhattan Beach. Specifically they are located on the northeast corner of the intersection of Manhattan Beach Boulevard and Walnut Street at 931 (for the McMartin Preschool lot) and 927 (for the first Goldstein lot) Manhattan Beach Boulevard (Figure 1).

In its original state, the property was relatively flat and consisted of open fields until quite recently. The fields had plant cover at the turn of the century consisting of low grasses and shrubs. For instance, the property may have been photographed in 1912 (Figure 8) which shows no heavy agricultural utilization or any constructions at that time.

A wood frame, one story house was constructed on the side lot (at 927 Manhattan Beach Blvd.) and is shown on a Sandborn Map Company, 1928 map (Figure 9). This structure was 30 x 32' and had a small front porch (the concrete steps which had led from Walnut St. to this structure were still present in 1985: see Figure 10 from Langenwalter, *et al.* 1985: 7-9, 14). The Sandborn map (see Figure 9) also shows a garage located on the north half of the lot which measured 20 x 25'. The house had a septic tank constructed underground which was rediscovered by our explorations (see Section 4.3 below). This side lot property as well as the lot which contained the preschool were purchased by a Mr. Mark Morris in 1942 (Langenwalter, *et al.* 1985: 7). Morris put the house up for sale in 1972 and apparently vacated the house in 1972. A demolition order for the house and garage was issued on November 3, 1972. The house and lot (the side lot) were then acquired by a Mr. and Mrs. Clifton Warren who in turn sold the property to its present owner, Goldstein, on January 28, 1975 (Langenwalter, *et al.* 1985: 7). The lot continued to be unoccupied during our field work and is still vacant as of the time of this writing in 1992.

The first construction on the preschool lot (i.e. 931 Manhattan Beach Blvd.) was the "Virginia McMartin Preschool" itself, for which the initial application for a permit was registered in December, 1962 (Permit, 1962). The building was built by C.R. Anderson and Co., Contractors, who submitted architectural plans which were approved on February 15, 1966 (Blueprint, 1966). The actual construction of the school conformed to those architectural plans (see Figure 1, which is taken directly from the architectural plans) for a single story wood-frame and stuccoed wall structure with a flat, gravel-covered roof. The school was L-shaped and built on a N/S, E/W basis. The long axis of the "L" was perpendicular to Manhattan Beach Blvd. and the short axis of the L, on the north, extended west towards Walnut St. (Figure 1). According to the floor plan, the "front", that is, the part of the school closest to Manhattan Beach Blvd., was the location of the office and a toilet. Next, going to the north, were three classrooms (herein labeled Classrooms



*Tree section street (Walnut?) before trees (c 1912).*

FIGURE 9: 1929 SANBORN MAP SHOWING SITE. Note locations of former house and garage on Side Lot; structures not present in 1990.

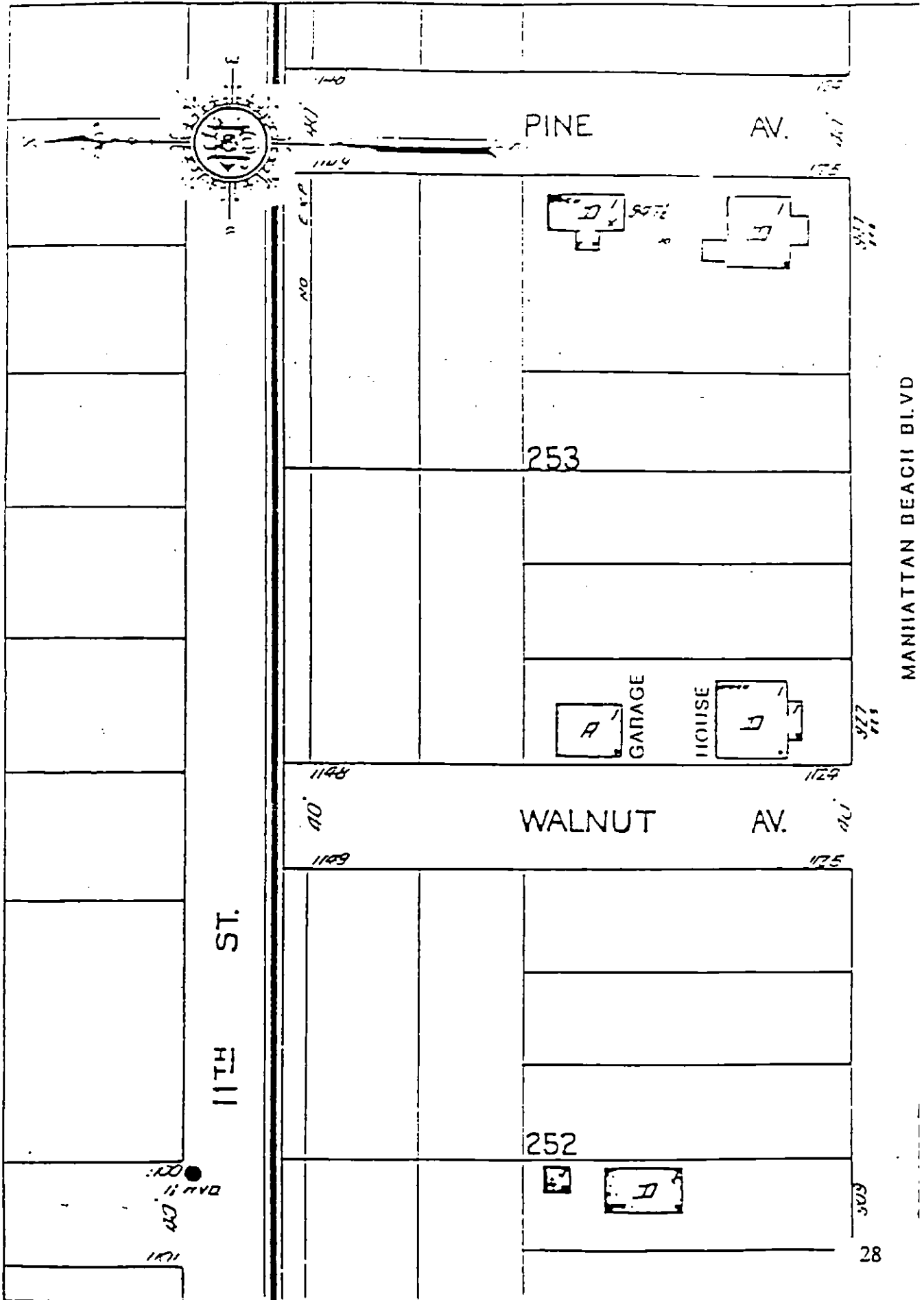

1, 2 and 3), each of which had a bathroom. One more Classroom (no. 4) extended west of Classroom #3, forming most of the short axis of the "L". A roofed concrete corridor extended the length of the building to permit access to all of the classrooms. The relatively small yard immediately adjacent to the classrooms was used as a play yard, in which imported sandbox-like sand had been placed to a depth of approximately 2 feet. A three course cinder block retaining wall topped by a chain link fence served to wall in this play yard. The wall was parallel with the westernmost wall of Classroom #4. The chain link fence part of the wall had been covered with dark green painted plywood panels about eight feet tall. There was an opening in this retaining wall near Classroom #4 on the north, which permitted access to the "side yard".

Another eight foot high fence of dark green painted plywood panels was placed around a rectangular area (6 x 19 m.) in the side yard that was adjacent to Classroom #4 and overlapped with the play yard's retaining wall (see Figure 1). The children were allowed to play in this additional play yard as well. The paneled fence blocked the view and access to the rest of the side lot (see Figure 1 for the location of the side yard within the overall lot). The side yard was also furnished with large, handmade wooden playground equipment. Ostensibly children at the school were kept within the play yard, classrooms, and the fenced-in portion of the side lot and not permitted to have access to the rest of the lot (McGauley, 1992). See Figure 10a-c for views of the preschool architecture.

Thus the two adjacent lots, the preschool building, and the soil deposits below formed the total area of our investigation.

## 2.2 Geological/Natural History of Soil Deposit on the Site

The City of Manhattan Beach rests on geologic deposits of ancient dune sands that were probably deposited during the last 10,000 years. This span of time is known as the Holocene Epoch of the Quaternary Period. Correspondingly, the project Geologist, Dr. Don Michael, noted these sand deposits at the subject site. He also observed that at some places at the site, there were developed sections of a relatively dark, more clayey material that he took to be a "rudimentary 'A' soil zone" (Michael 1992a: personal communication; cf. Appendix I.3a).

The geologist noted, in his preliminary inspection of the soil deposits as exposed in the trenches and units we dug under the preschool, two artificial (man made) "episodes of filling" (Appendix I.3a). The older fill was placed on a slope that originally extended downward to the north across the site's lots. It apparently was comprised of dumped sand which included some junk and organic debris within its matrix. This observation is consistent with a statement, apparently made by the builders of the preschool, that they had filled in the back of the lot in 1966 to level the ground for construction (*Easy Reader*, 1990: 3,9). The younger episode of filling "...had evidently been placed under controlled conditions, i.e. compacted to a predetermined density as is required by the local building code" (Michael, 1992a: personal communication).







The geologist also made a sketch (see Figure 18a) of an excavated feature that was different from the two episodes of filling noted above. This feature was an area of disturbance, clearly distinguished by loose, disturbed soil and artifacts contained within it. This feature was located under the foundation footing of the west wall of Classroom #4. The outside profile of this large feature had a reversed bell-shaped curve profile. It was measured in from the northwest corner of Classroom #4. Measuring disclosed that the feature profile began some 2.3 m. (7.5') from the reference point and extending southward beneath the structure's footing for some 5.02 m. (16.5'). Thus the width of the feature at the top was 2.7 m. (9'). There was, therefore, no top or "roof" of soil to the feature at that point. The roof at that point was provided by the bottom of the concrete foundation whereas inside there was a roof of soil observed. The bottom of the feature was rounded, but it permitted a measurement of some 1.42 m. (56" or 4.7') in width. The "af" designation by the geologist on his drawing (Figure 18a) was a notation to indicate the "artificial fill" within the feature.

The geologist observed that this feature was a "hole" of some kind that had been excavated under the foundation. He could not tell the age of the excavation (Michael, 1992a: personal communication). The geologist then refers to the plastic Disney bag that had been discovered in the feature's fill (see Section 1.2 above) and notes in his report that it was a "...piece of plastic beneath the slab with a date that was later than the date of construction [of the preschool]" (Michael, 1992a: personal communication; cf. Section 5.3; Appendix I.3a). In an addendum response to the author's request for clarifications (cf. Appendix I.3b), Dr. Michael clarifies and augments these interpretations. He believes that the feature is a "cavity", and due to the presence of the Disney bag found within it, he believes "Therefore, the cavity could be no older than 1983..."(Michael, 1992b: personal communication: Appendix I.3b).

The project area itself has a deposit of very sandy soils. These soils range in color from (using the Munsell, 1975, color system) 5YR 6/3 (light reddish brown) to 7.5 YR 4/4 (dark brown). Because the soils were so sandy, the deposits at the preschool site were very unconsolidated (in terms of the author's experience and in comparison to other hard or hardpan deposits) and relatively easy to excavate. Such light-colored, sandy deposits often show intrusive features such as former excavated holes or openings very clearly and thus yield good "signatures" of past human or natural subsurface disturbances within the naturally developed and stratified soil deposits. The "cavity" described by Dr. Michael above is a clear example of such a signature.

### 3.0 Excavation Methodology and Methods

#### 3.1 Site Excavation Methods

A permanent Master Datum was established as the northeast corner of the intersection of Manhattan Beach Boulevard and Walnut Street (Figure 11). A Master Datum serves as a point of reference so that all pits/units and artifacts excavated can be measured so their spatial distributions and vertical depths can be reconstructed in later analysis (see Figure 11 for locations of all units and trenches we explored). A secondary site datum was

FIGURE 11: MAP SHOWING THE TWO LOT SITE AND ALL EXCAVATED UNITS

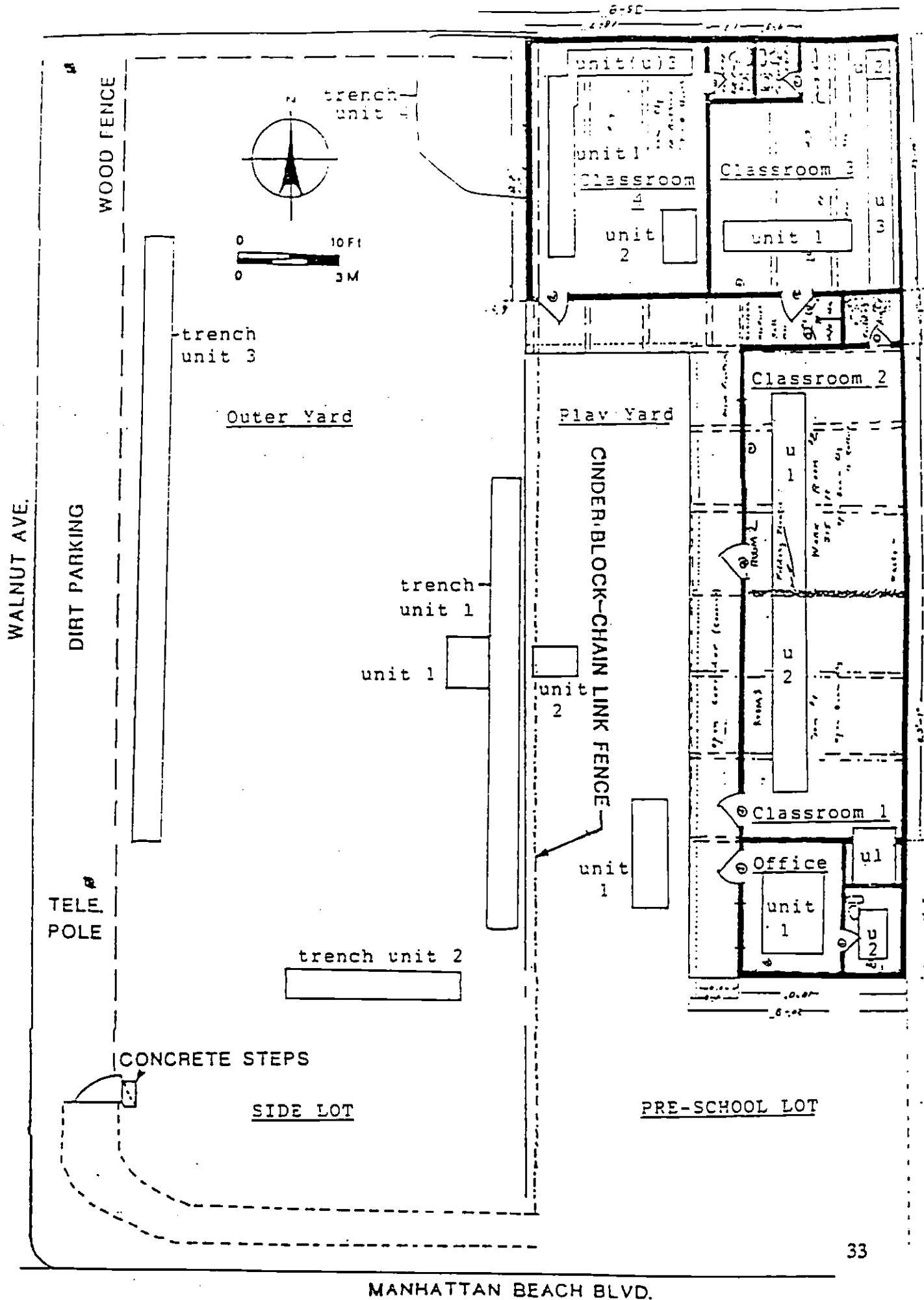

units was passed through 1/8" shaker screens to recover small finds. It should be pointed out here that unlike a usual archaeological dig, we were searching for highly selected data, and although we dug levels in standard increments (i.e. 20 cm. levels) down, it was not necessary to absolutely maintain equal volumes of excavated levels (traditionally useful for comparative statistical analysis of all finds contained within levels).

Recovered data were bagged in plastic zip-lock bags, labeled with their provenience of pit/unit, depth, and any other pertinent factors and given a field number.

This was an unusual archaeological project in that the standard project explores sites with the intent of excavating pits or units in such a manner that the artifacts and other data recovered from them are used to characterize the range of human activities (e.g. hunting, gathering, stone tool manufacture, or, in the case of Historic Archaeology, to document the foundations and other architectural features of a colonial house, for example). This project was different in that the goals of the project were highly restricted to search for the reported tunnel(s)/room(s) and to recover any other data relevant to the aberrant behavior reported by the children. Therefore the decision not to lay out a traditional grid system allowed for accurate spatial control over unit location using the then-existing preschool structure. Also traditionally the pits or units excavated at a site are placed either randomly or nonrandomly with respect to a site-wide locator grid system. That approach was not appropriate in this project. The approach that was taken is discussed in the next section.

The basic information recovered by this project is being stored by the originators of the project. Artifacts, photographs, notes, etc. have been continuously curated by them since the completion of the field work.

### **3.3 Use of Ground Penetrating Radar and Informant Reports for Unit Selection**

The placement of units was made on the basis of two factors: 1) verbal reports by the children to the parents describing where the tunnels and tunnel entrances had been and 2) anomalies and targets detected by our use of Ground Penetrating Radar. The latter was considered when a target was large enough and deep enough to be a possible indicator of a subterranean feature.

## **4.0 Excavated Units, Recovered Data and Analysis**

### **4.1 Unit Placement and Excavation**

The following unit designations were given to the excavations beneath the preschool structure and outside in the adjacent play yard and outer yard areas respectively. Beginning with the units beneath the structure floor (note that the units underneath the preschool were those dug down in rectilinear openings cut through the concrete pad floor in the various rooms indicated) and starting with the preschool's office, (see Figure 11 for all unit locations with respect to the structure floor plan and for the two yard areas) one large unit, Unit 1 measured 2.8 m.(9.2') N/S x 2.1 m.(7') E/W). Office Unit U-1 covered most of the office's floor. Another rectangular unit, Office Unit U-2, was excavated below the floor of the office toilet. It measured 1.7 m. (5.5') N/S x .95 m. (3.1') E/W.

Next the four classrooms (going from south to north and northwest) were designated as Classrooms 1, 2, 3, and 4 respectively. Two units were excavated in Classroom #1. The first, U-1, was excavated below the toilet, measuring 1.9 m. (6.2') N/S x 1.5 m. (5') E/W. Classroom #1, Unit U-2 was a long, trench-like excavation that extended north/south on the western half of the room. Unit U-2 measured some 6.6 m.(21.5') N/S x 1.2 m.(4') E/W. The partition wall that had separated Classrooms #1 and #2 originally was a sliding paneled partition that could close off or open up the two adjoining classrooms. We opened up the partition and had the concrete cutters cut a long trench (U-2) not only across Classroom #1 but also across (on the same axis) Classroom #2. For purposes of providing provenience control (i.e. having smaller units to facilitate the recording of any items/data found within a given trench), the opening in Classroom #2 was designated as Classroom #2, Unit U-1 even though it was, in actuality, a continuation of the trench (U-2) from Classroom #1. Unit U-1 extended virtually across the entire floor of Classroom #2 and measured 6.6 m.(21.5') N/S x 1.2 m. (4') E/W.

Three units were placed in Classroom #3 due to the concentration of reports by the children of activity there. Classroom #3, Unit U-1, was a long trench, the opening of which was cut to investigate a Ground Penetrating Radar (GPR) anomaly detected on its westernmost end and up to the partition wall to Classroom #4. The excavated U-1 measured 4.5 m. (14.8') E/W x 1.0 m. (3.3') N/S. Unit U-2 in this same classroom was a pit which the parents had begun excavating immediately prior to the project. They dug down some 26" (99 cm.). Because it was deemed important to further explore that area, we designated the opening as U-2 and continued excavation. Unit U-2 measured 80 cm.(2.6') E/W and 100 cm.(3.3') N/S. Unit U-3 extended from U-2 directly south, intersecting U-1 and continuing to the partition wall of Classroom #2 on the south (see Figure 11). Its width measured 80 cm. (3.8')E/W and its overall length was 7.0 m.(22.1') N/S.

Classroom #4 contained the remainder of the units excavated under the preschool structure. Unit U-1 was a trench-like excavation that measured 6.0 m. (19.20')N/S in length by .9 m. (3.2') E/W (and 1.0 m. [3.3'] in width at its wider northern end). Classroom #4, Unit U-2 was rectangular and measured 1.8 m. (6.0') N/S by 1.1 m. (3.5') E/W. Note that it had been placed in the southeast corner of the room due to an anomaly detected by the Ground Penetrating Radar. Finally Unit U-3 was another trench that measured .89 m (2.9') N/S by 4.1 m.(13.5') E/W.

The following units were placed outside the preschool structure in the Play Yard (see Figure 11). Play yard Unit U-1 was placed in the southern part of the yard, about 2' west of the concrete walkway bordering the classrooms. The unit was placed at that location in response to a buried anomaly detected by the Ground Penetrating Radar (see Appendix I.7). Unit 1 was rectangular and measured 3.7 m.(12') N/S by 1.2 m.(3.9') E/W. Another unit, Unit 2, was placed in the Play Yard. This unit measured 1.0 m.(3.3') N/S and 1.5 m. (3.4') E/W. Unit 2 was placed across the chain link and short cinder block delimiting wall from the Outer Yard's Unit 1. This was done in order to determine if a buried trench feature (first identified in the Outer Yard) continued into the Play Yard.

In the area we termed the "Outer Yard" (also called the "side lot") there was another unit placed which we designated as Outer Yard Unit 1, measuring 1.75 m. (5.75') N/S x 1.5 m.(5.0') E/W. This unit was placed on a direct line west of Unit 2 in the play yard, and on the edge of a backhoe trench, Unit 1, which we made east/west just outside (west) of the 3 course high cinder block retaining wall. This unit was placed in order to clarify a buried feature seen in backhoe trench 1. Unit 4 (also called Trench Unit 4) refers to some excavation, data collection and profiling we did of an irregular-shaped area located next to the western wall of Classroom #4. This area had been dug superficially by the parents, by the District Attorney's Office archaeological dig in 1985 and some preliminary digging with a backhoe by the project crew just prior to the formal archaeological excavations of this project in 1990 (see the discussion in Section 1.2 and 1.3 above). Three other areas were explored in a less formal way by backhoe trenches (1, 2, and 3).

Some additional excavations were made between some of the units underneath the preschool in order to follow out the lay of the tunnels under the office and in rooms 1, 3 and 4. These are described in Section 4.4 below.

#### 4.2 Results of Test Pit and Test Trench Search Excavations

Unit 1 was placed in the preschool Play Yard to investigate a large slab-like GPR anomaly (see Appendix I.7). Although the technicians operating the GPR estimated it to be at a depth of 6-8 feet, the feature, a crudely poured slab of concrete, was found by us to be buried only a foot down. The rectangular slab was 2-5" (5-13 cm.) thick and had crude and irregular edges. We broke up the slab and excavated below it some 1.5 m.(4.9') but we could find nothing that would indicate any function it had served. Thus the purpose of the strange buried feature remained unknown and we directed our efforts elsewhere.

Next, excavations were conducted in the westernmost sector of Unit 1 in Room 3. This was selected because a GPR anomaly was detected through the concrete floor in an area next to and continuing up against the west dividing wall between Classroom #3 and #4 (Figure 12 shows the GPR anomaly recording). Since we could see no pattern at that time, we decided to excavate the rest of the trench in 1 meter increments starting on the west and going east. The trench-like unit was divided into four 1 x 1 meter sectors (the easternmost was larger at 1.5 x 1.1 meters). These were labeled for provenience purposes as sectors 1, 2, 3 and 4 respectively.

At this same time the crew excavated pit-like Room 3, Unit 2 down below the 6'10" depth dug by some of the parents previously (see Section 1.3 above). This pit was dug down some 2.74 m. (9') and although some items were recovered, no discernible pattern could be seen at that time and excavation at that locus was stopped for the time being.

With continuing excavation in the room #3, Unit 1 trench, some items were being encountered beneath the preschool floor, such as 5 connected links of chain and a whole humerus bone from a goose (see Appendix I.4) both found at 15 cm. depth in sector 2; and a tin can found in sector 2 at 24 cm. below the surface. On the western half of sector 3 there was a noticeable soil color change (from lighter color Munsell 7.5 YR 4/4, a relatively light "dark brown" to 7.5 YR 3/4 "dark brown") and subsequently the top of half of a

FIGURE 12: COPY OF GROUND PENETRATING RADAR PRINT OUT SHOWING TUNNEL SIGNATURE AS DETECTED IN CLASSROOM 4

Typical ground penetrating radar profile from Area Three

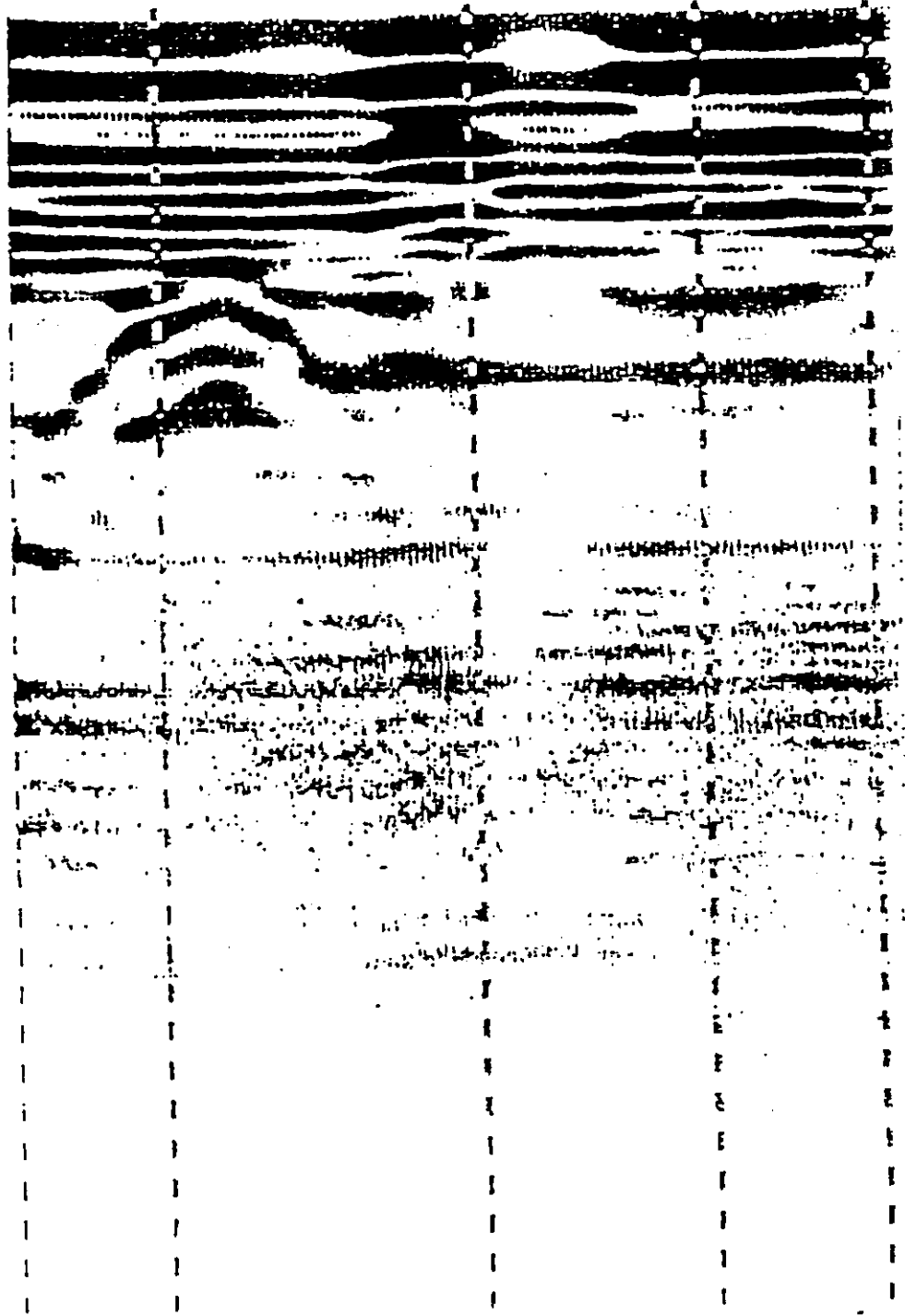

5 feet between vertical dashed lines

broken cinder block was uncovered at a depth of -14 cm. in that part of the sector. The feature was more fully exposed by troweling and brushing until both halves of the cinder block brick were uncovered. These two brick fragments were lying on top of each other and the bottom of the lower brick went down to -52 cm. A snack-size cellophane wrapper was located next to the bricks at -35 cm. (see Figure 13a for the *in situ* appearance of the brick feature). These large artifacts obviously showed that the area had been disturbed previously, having been dug into for some purpose by the hand of man. It is possible for very small artifacts to intrude into a given soil deposit due to the activity of burrowing rodents such as the locally active ground squirrels (the process of soil deposit disturbance by such animals as squirrels, gophers and the like is formally termed "bioturbation").

This locus was further carefully excavated to attempt to determine the nature of the human disturbance. Then at -70 cm., and directly below the two concrete block fragments, a 3" metal pipeline was uncovered. A number of human-introduced items were found in association with the pipe, such as two separated, large mammal bone parts and a more distant burnt bone fragment (20 cm. to the northeast of the northern portion of the pipe (see Appendix I.4 for specific information on these bone fragments). Also in association were a small area of brick mortar fragments and 3 aluminum antenna fragments. It was identified that this north section of pipe angled to the northwest towards the toilet in the classroom and served as its waste pipe. Ostensibly the pipe would have originally been lain in a trench for that purpose and that could explain the disturbance around the pipe and the presence of other associated artifacts such as the two concrete block fragments. However, two stainless steel clamps were observed, connecting the northern section of pipe to a southward running section via an angled fitting (see Figure 13b for the *in situ* appearance of the two clamps on the subject pipes). The presence of these clamps led to a series of specific questions.

These two clamps (artifact catalogue Nos. 560 and 561 respectively) were notable in that they appeared to be brand new. That is, they were of a very shiny silver color and exhibited no (or very little) patina (surface dulling or chemical modification of metal or glass artifacts due to physical/chemical alterations caused by the environmental conditions of the artifact). These clamps appeared to be of more recent age than the construction of the preschool (i.e. more recent than 1966). This is because they did not exhibit to the author enough corrosion or patina to have been exposed to physical/chemical buried ground effects for almost a quarter century (24 elapsed years). This comparative observation was more apparent when we excavated similar pipe clamps elsewhere in the preschool and compared them (see Figure 36b where considerable patina can be seen on clamp No. 563 found in the Office, Unit 1, and on clamp No. 562, found in Classroom #2, Unit 1, which has good patina development). Since no opening through the floor large enough for a human to have placed the clamps on the pipes could be seen at that moment of the excavation, it was puzzling to us how they could have been put on.

It should be noted here that the original trench which had been dug during the construction of the preschool to accommodate the pipeline could be observed in the north wall of the trench-like Unit 1. This filled trench surrounded the pipe it contained and it

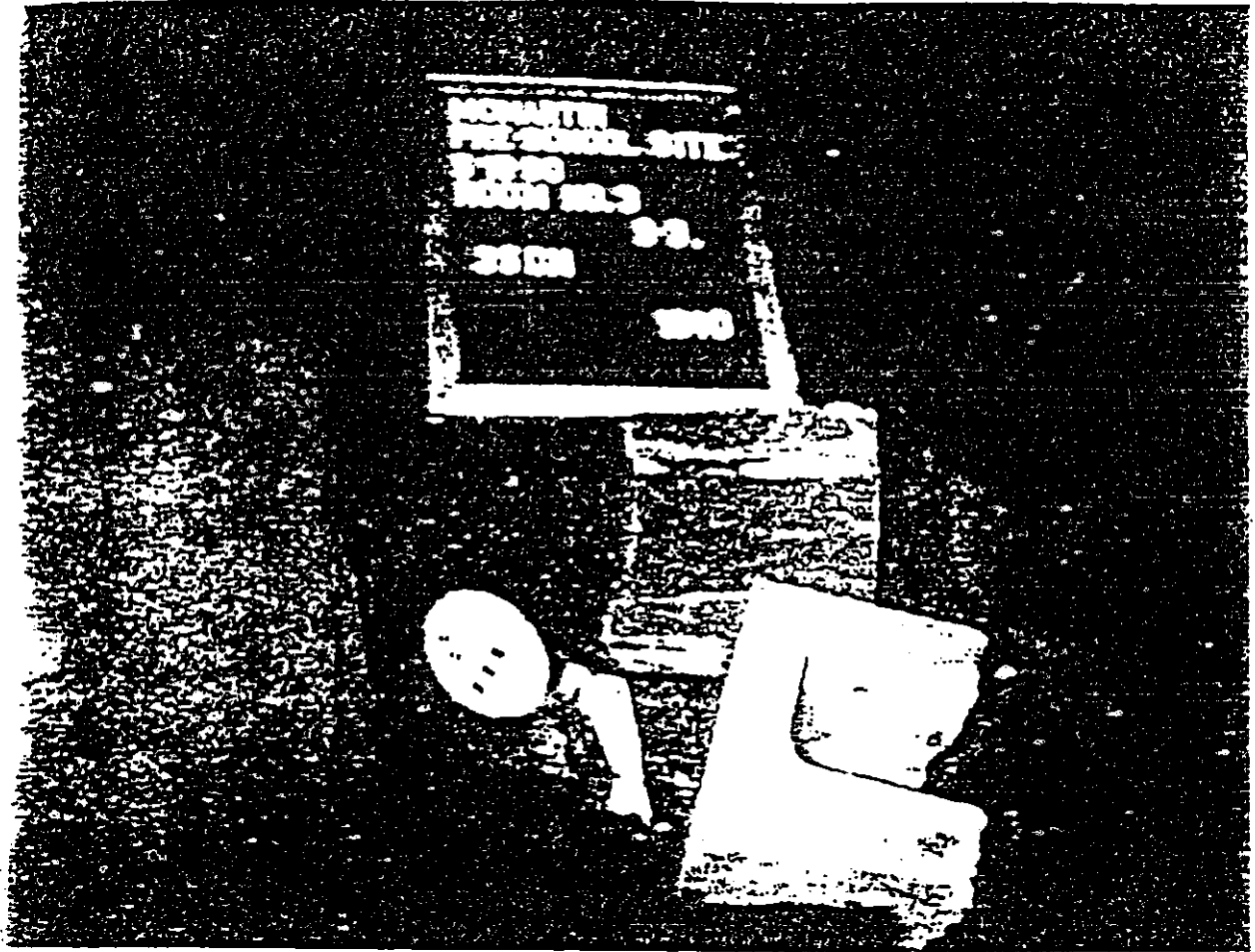



... ..  
... ..  
... ..  
... ..



could be observed continuing into the north side wall of Unit 1. This shallow pipe trench could certainly be excluded as a candidate for a tunnel. However the presence of the new-appearing clamps on the pipe still remained a mystery to us at that point. Post excavation lab analysis disclosed some relevant facts about these artifacts (see Section 5.5; Figure 36a, and 36b; Appendix I.5).

Although sector 4.5 was then excavated down to the same level as the pipes/clamps, no additional data were found at that time to clarify the situation and the work was continued elsewhere.

As we were moving our excavation equipment, one Paul Barrons, a private investigator working for the defense, barged onto the site, refused to stop and identify himself, rushed into Classroom #1 and went directly to inspect the defunct toilet room. We confronted this individual and called the police. Barrons quickly left prior to their response (KCAL TV., 1990). His visit coincided with an effort made by the defense to obtain a restraining order to stop our excavation/ exploration of the site (KCAL TV., 1990). This was a curious move if, as the defense maintained, there were no tunnels or any other evidence to be found at the preschool site. Consequently we decided to continue our excavations in that toilet room (Classroom #1, Unit 1).

Upon excavation of the first level of Unit 1 (the 0-20 cm. level) below the concrete floor, we found the soil of the unit to be very soft. Inclusions or intrusive items found in the soil included pieces of charcoal, pieces of red paint, wire, bits of plastic, a bottle, some glass shards and some nails.

The excavation continued down in the unit with the scant historic artifacts contained in the deposit (charcoal pieces, metal pieces, etc.) diminishing as we went deeper. Then at the 80-100 cm. (31.5—39.37") level the light-colored soil of the deposit (5 YR 6/3, light reddish brown on the Munsell Color Chart) gave way to a feature of darker colored soil (5 YR 4/3, dark brown) on the eastern half of the unit against the foundation under the concrete pad floor, and extending in a curvilinear arc to the southwest of the unit. This feature was a subterranean area of artificially disturbed soil. It appeared to represent some sort of a human-excavated pit or opening that had been back filled (see Figure 14a). It was clearly distinguishable from the smaller rodent hole burrows that existed in the deposit. We continued to dig deeper and the size of the feature expanded until it covered most of the unit (see Figure 14b). We finished the excavation at a depth of 3.9 m. (12.83 feet).

Based on his recollection, the Assistant Field Director, Don Flaherty, observed the excavation made by workmen in Office Unit 1 who dug under the concrete pad floor southward up to the foundation of the south wall. He observed what appeared to be a tunnel feature that extended in a north/south direction across Unit 1 and it appeared to him to terminate near the south wall area. Flaherty recalls that the feature's average width was about 60 cm. wide and its bottom was about 80 cm. in depth. Flaherty was certain that this feature connected to the feature he first excavated in the Classroom #1 toilet, Unit 1, (Flaherty, 1992: personal communication).

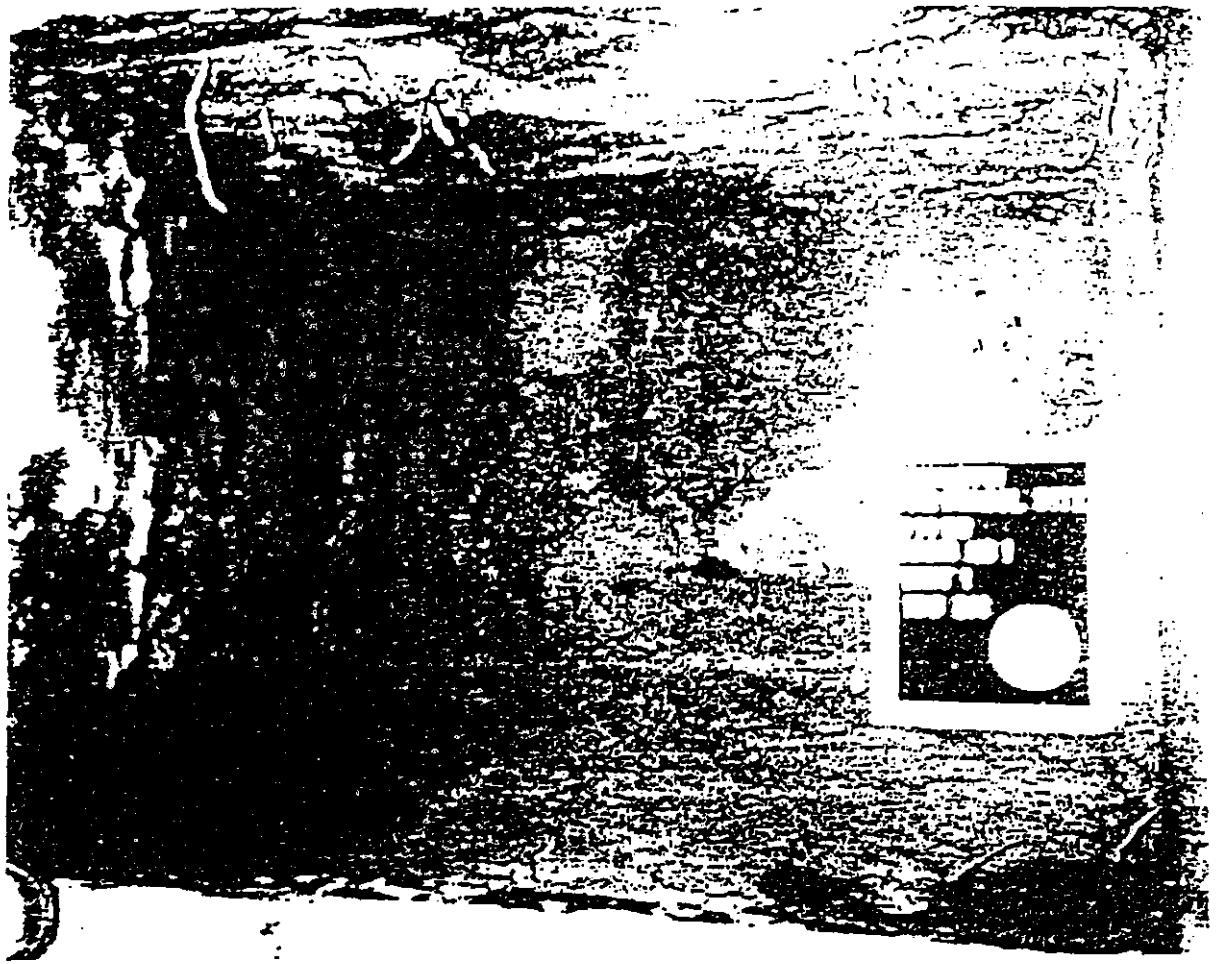

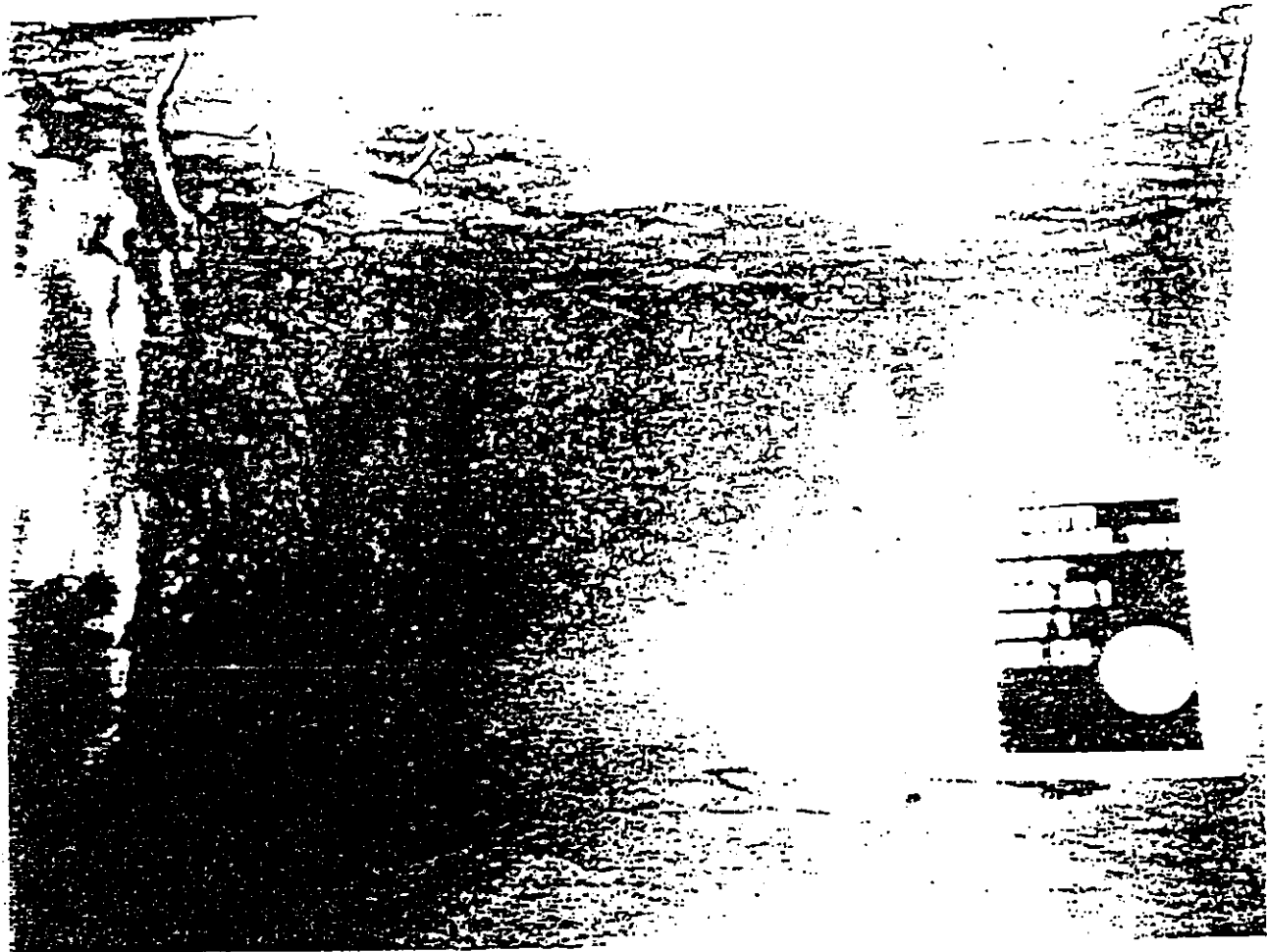

At that time, a decision was made to further explore the feature in Classroom #1, Unit 1, which appeared to extend southwestward and beyond the Classroom #1 toilet area. We then excavated in the Office (Unit 1) where the feature continued in the eastern 1/4 of the unit. Since it appeared to continue south and west from Unit 1, we continued to explore the feature by excavating Unit 2 in the Office toilet room. The deposit between the two units was excavated out as well. All the while the same colored soil (5 YR 4/4, dark brown) continued to distinguish the feature. The feature soil was more loosely compacted and was much more dark in color than the surrounding non-feature soil (5 YR 6/3, light reddish brown). The feature continued eastward in Unit 2, and the farther eastward we dug, the closer to the surface the profile (the distinguishable vertical and horizontal appearance of a feature) became until it was within 60 cm. (2') of the surface of the neighboring lot. Thus the feature continued up to (and obviously continued beyond) the east wall (outer wall) of the preschool.

At that point we had to stop horizontal exploration of the feature, since we did not have permission to excavate on the triplex property next door. We then dug down in order to define the vertical profile (depth) of the feature. It became apparent that the feature had been back filled with earth that contained virtually no artifacts or ecofacts. The matrix (soil deposit) in the feature did contain numerous flecks of charcoal and carbon and pieces of plaster with green paint (which the excavators hypothesized might be remnants of the green paint that had been applied to the school in "1984 or 1985" (Hobbs, 1990) and possibly the fire that had occurred at the site on April 8, 1984 (*Daily Breeze*, 1984a).

Jerry Hobbs noted that the roots from a lemon tree on the adjacent triplex lot (see Figure 1) were protruding into the fill of the feature near the eastern preschool wall and under its concrete foundation (see Figure 15 for a composite photo of feature).

In Figure 15, the dark and light curved layering of the feature's fill can be seen. The width of the feature was 91.3 cm. (3') at that point where it crossed the western edge of Unit 1 and it was upwards of 1.5 m. (5') at the eastern edge of Unit 1 (see Figure 15 where the curved, multi-layered fill deposit, the lemon tree roots and the underneath portion of the concrete foundation of the preschool [top left] can all be seen). The maximum depth of the feature at that point was 1.83 m. (72" or 6'). The feature was followed also from below the Classroom #1 toilet room into the Office and into and completely across the Office toilet room for a total distance of some 8 m. (26.2').

In summary, this feature was large and curvilinear and appeared to be directional, in the sense that it apparently led to the neighboring triplex (see Figure 20a below for its location and shape). Although it lacked some of the test-expected variables (e.g. a well defined roof, inclusions of numerous artifacts and the like), it nonetheless was a good candidate for a tunnel because it was, for example, traversable by an adult human. The feature, which ran beneath the two toilets and the Office, may well have been connected to the triplex next door, according to evidence gathered by Jerry Hobbs and the crew, who explored the triplex separately from our archaeological work *per se* (see their discussions in Appendix V).

FIGURE 15: COMPOSITE PHOTO VIEW OF POSSIBLE TUNNEL SIGNATURE IN FILL UNDER  
FOUNDATION OF OFFICE TOWER (LOOKING EAST)



Although excavations were pursued in Classroom #1, Unit 2 (the long trench) nothing definable and relevant to the project goals was encountered. While incidental nails and other small trash were found, all of those items could have been introduced by rodent activity (bioturbation).

Next we excavated the long trench (Unit 1) in Classroom #2. In the south half of the trench, a number of miscellaneous historic artifacts were found along with one prehistoric Native American utilized chert flake (Catalog MP439B). While excavating the north half of the trench we encountered a discrete (circumscribed and unconnected to other areas or features) trash pit containing an assortment of old bottles, tin cans and other trash similar to those which we found in Classrooms #3 and #4. The trash pit was located 1.98 m. (6.6') south of the north edge of the unit. The pit was defined on the western edge of the trench and continued into the side wall of the trench. We excavated into the side wall and determined that it only extended some 51.7 cm. (1.7') westward into the side wall. Thus the feature was a discrete trash pit roughly circular with a diameter of 1.01 m. (3.2'). Since this feature was discrete and since no other tunnel or tunnel-like features were encountered, we terminated work in Unit 1 and went to work elsewhere.

The author made a decision to search for subterranean openings in the side lot. Subsequently a backhoe was brought in which dug out several longitudinal trenches down some 2.4 m.(6-8', see Figure 11). A feature disclosed by our first trench (which we designated as Side Lot Trench Unit 1) led our attention to the outer yard. That is, we excavated a backhoe trench along the western side of the preschool Play Yard cinder block retaining wall. At a locus, located some 9.30 meters (30.5') south of the southwest corner of Classroom 4, we encountered a buried feature whose profiles were exposed directly opposite each other on the two "walls" of backhoe Trench Unit 1. We carefully troweled off the vertical faces of the trench at that point and exposed two profiles of the feature on either side of the trench.

The feature appeared to be a buried opening (that had been back filled) of a trench or possibly of a trench that had been covered over for a tunnel. Its depth was sufficient for an adult person to pass through if bent over. We decided to excavate the first unit in the Outer Yard (Outer Yard, Unit 1) which was a 1 x 1 meter pit, in order to attempt to detect further indications of a "roof" or other tunnel test expectations. That effort proved later to be fruitless.

A decision was made to open up another unit in the preschool Play Yard, directly on the other side (i.e. immediately east of the 3 course cinder block retaining wall) of the profile of the buried trench-like feature. This was done in order to ascertain if the feature was indeed a tunnel (being one that would have run under the retaining wall and then under the preschool structure itself at some point.

Upon excavation of Play Yard Unit 2 (see Figure 11) a darker colored (10YR 5/3 or brown: Munsell, 1975) sector in the unit (located in the northwest quarter of the pit) was noted that corresponded to the buried feature detected in the Outer Yard backhoe trench. Further excavation intercepted part of the buried trench as an incompletely filled opening appeared in the side wall and excavated "floor" and up against the east side wall of the unit.

Further excavation disclosed that the buried trench-like feature did not extend into the preschool play yard but terminated at the cinder block retaining wall. This buried feature was then identified as one of the east/west backhoe trenches that had been dug by the parents in their search at the side lot in 1985 (cf. Langenwalter, *et al.* 1985). Thus the feature could be eliminated as a possible tunnel.

Other noteworthy data were encountered in Play Yard Unit 2. In the first 20 cm. (our standard level depth) a dark green paint spot area was detected in the western half of the pit at a depth ranging from 5 to 9 cm. below the surface. Also an area of charcoal flecks was noted throughout the deposit in the northwestern sector of the pit (throughout the 20 cm. level).

An unusual find was made at 76 cm. south of the north wall and 56 cm. east of the west wall of the Unit and at a depth of 45.6 cm. (18"; Figure 16a; note the "5 cm." on the provenience board in Figure 16a refers to the depth of the board, not to the artifact). This was a plastic plate or saucer, possibly for a child's tea cup set. When its encrusted sand covering was brushed off, the off-white colored plastic plate exhibited a decoration of three pentagrams (one large in size and two small in size). This artifact was carefully measured in for its provenience and photographed *in situ* (see Figure 16a). The diameter of the plate was 8.3 cm. (3.25") and it was .5 cm. (.25") in height.

One member of our archaeological team, Ms. B. J. Schenk, did some research on the pentagram and its symbolic meaning over time. Although it had a variety of meanings (Koch, 1930: 6) the pentagram is well known as an occult symbol (Lehner, 1950: 97; Wedeck, 1961: 192; Worth, 1971: 11). This usage probably stems from the ancient Iron Age European Celtic Culture whose priests referred to the symbol as the "witch's foot" (Koch, 1930: 6; Lehner, 1950: 97).

When the plate was first discovered, the author observed the designs of the pentagrams on it and their appearance led to his initial interpretation that the designs had been manufactured onto the plate. Later analysis by Jeff Minard, the project's historical artifact analyst, disclosed that the stars had been carefully inscribed and painted onto the plate by hand in a very precise manner. In the opinion of the historic artifact analyst, the three pentagrams had to have been executed by an adult: a child of preschool age would not have the motor skills necessary to perform such precise engraving and painting.

Most pentagrams the author has seen previously were symmetrical (i.e. the star would appear to be balanced from all viewpoints). However this artifact (#MP 2 as it was later catalogued) exhibited a very sophisticated design in that not only is the large pentagram asymmetrical but the two small pentagrams drawn between its starpoints were also drawn in an asymmetrical style (see Figure 16b). This style gives the pentagrams (especially the large one) the appearance of looking "off-balance" from all viewpoints around its perimeter except one. That is, when the large pentagram is viewed from the perspective that has one of the small pentagrams placed at the bottom, the large pentagram then looks "balanced" (see Figure 16b). This indicates that there is a symbolic relationship between one of the small pentagrams and the large one.





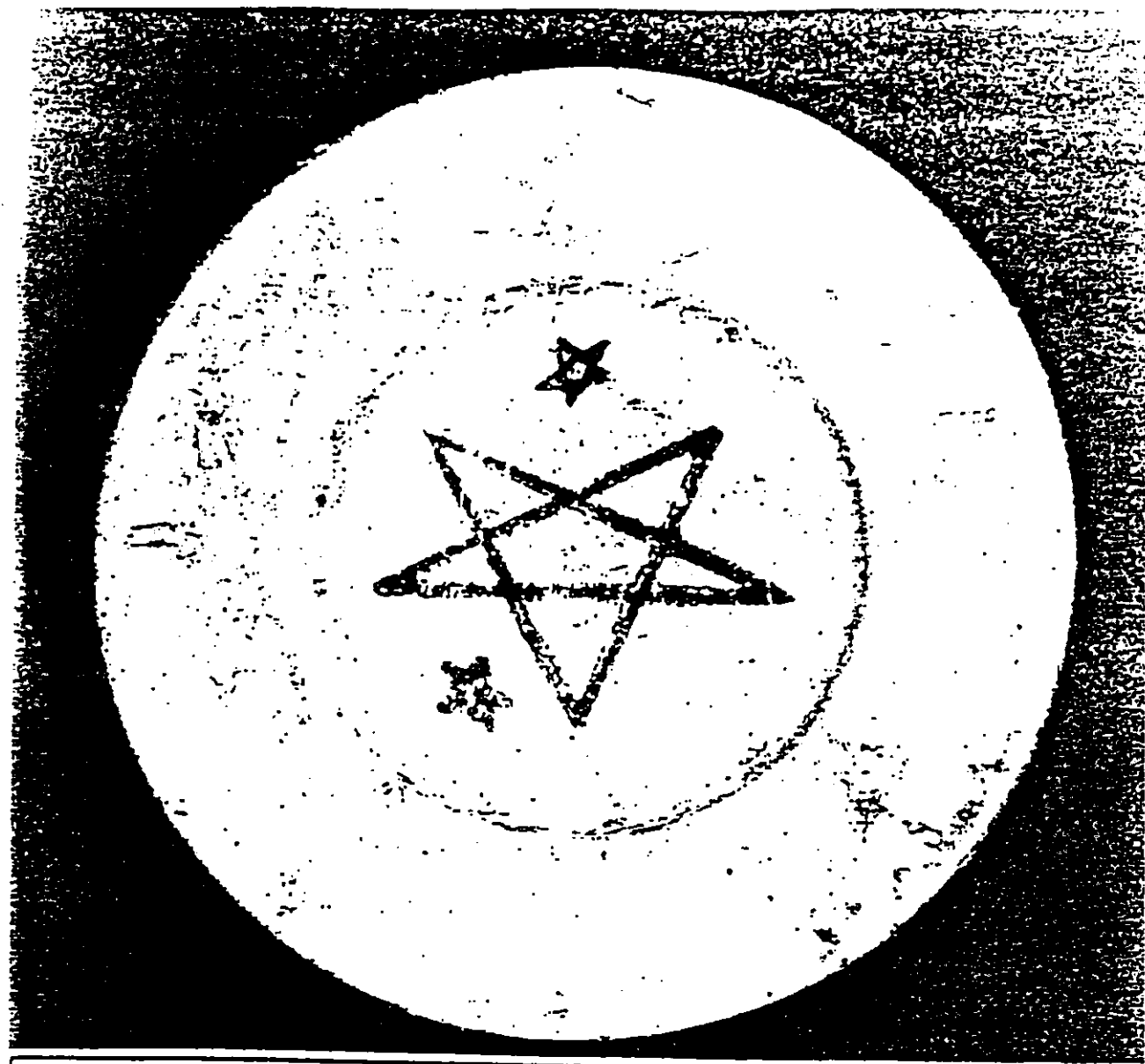

2  
CM

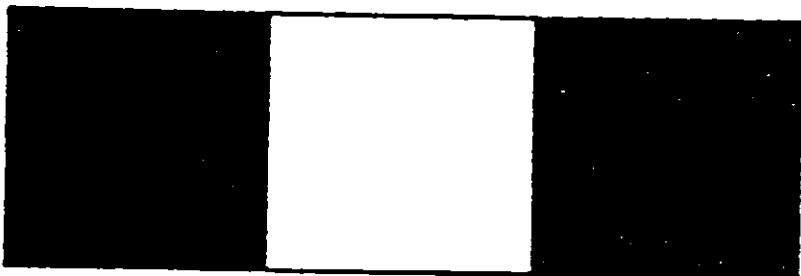

1  
IN

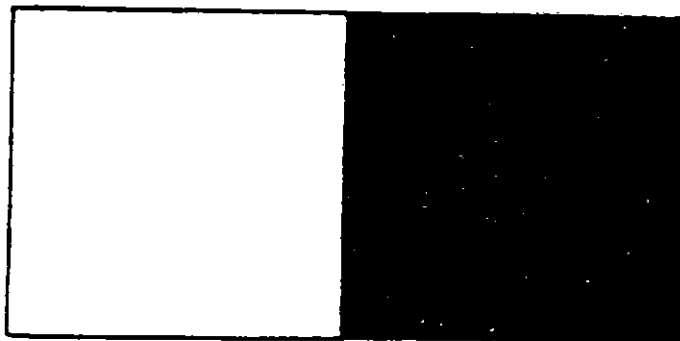

The relationship of the other small pentagram is not clear but such small symbols, located between the starpoints of a large pentagram are known (cf. Worth, 1971: 11). A relationship is also indicated by the fact that the small pentagrams also visually appear to be "balanced" when they are seen from the viewpoint of one of the straight axes of a starpoint below. In addition, the center of the small pentagrams were not left blank but had been painted with green paint. It should also be pointed out that it may not be a coincidence that all three pentagrams were drawn on the flat receptacle surface of the plate because, when viewed from above, the perimeter of the receptacle forms an inner ring to the outer ring of the outer edge of the plate. This may have been a symbolic way to represent "the double rim" important in some symbolic uses of pentagrams (cf. Worth, 1971: 11).

Since the plate had recognizable symbols associated with the occult, which would appear to corroborate prior statements of the children concerning behaviors that had been witnessed at the site, it was treated as a special find. Excavation below the plate went down for some 40 cm. with no further data of import encountered.

We further explored the various trenches our backhoe had dug across the Outer Yard. We dug the relatively short E/W Trench 2 on the south side of the lot, but we found nothing of note within it. As we inspected the northern sector of the long N/S Trench 3, we noted a large, buried, rounded-bottomed feature which we called Feature 1. Since no salient data could be detected with the feature we moved on. Another artificial area was detected in the central sector of Trench 3 which we labeled as Feature 2. This was a large, buried rectilinear facility of dark soil which had two long 4 x 4" posts still preserved at its north and south corner boundaries. This feature turned out to be a septic tank that had been associated with the former house on the property last occupied by the Morris family (see Section 2.1 above). This septic tank was located in an area that would have been between the former house and its garage (see Figure 9).

Turning again to Trench 1, in its northern sector, we relocated one of the units dug by the District Attorney's archaeological dig in 1985. This shallow unit (about 40 cm. in depth) can be correlated with the District Attorney's dig, Unit 7 (see Figure 4 ; cf. Langenwaller, *et al* 1985: 14). This prior unit had been back filled and contained one of the wooden stakes originally used to lay out the guideline strings at its surface. Thus we were able to eliminate a variety of buried features as not being the sought after tunnels or buried rooms (i.e. the parents excavated backhoe trenches, the buried septic tank, and the prior archaeological pit or unit). A decision was then made to reinvestigate the area adjacent to the west wall of Classroom #4, which we designated as Outer Yard Trench Unit 4.

As noted above (see Section 1.2), this area had been dug up by various persons prior to this formal archaeological investigation. The parents dug there because the children reported that it was an area of the tunnel and room (cf. Langenwaller, *et al*, 1985: 13) and that is where the parents found the possibly inflicted tortoise remains (see Figure 3; Langenwaller, *et al*, 1985: 20-29; Figure 6), which discovery forced the District Attorney's Office to finally conduct their own excavation. Subsequently, the D.A.'s archaeologists dug five clustered units (their nos. 1, 2, 4, 5 and 6) immediately next to Classroom #4. Then,

as noted above in Section 1.3. Jerry Hobbs and the project crew made preliminary excavations at this locus where they encountered more historic trash both immediately outside and just under the foundation of Classroom #4, including the cut-off gap in the avocado tree roots and the plastic Disney bag with the 82/83 date. Although sections of this area had been disturbed by all of those previous diggings, given the lack of other indications of tunnels and given the diminished amount of time left to our project, a decision was made to reinvestigate this area and resolve the questions remaining about it.

We excavated Trench Unit 4 down through recently introduced sand and gravel layers of fill and dug through the plastic sheeting laid down at the bottom of the excavations made by the D.A.'s archaeologists (plastic sheeting was used for the purpose of showing where the archaeological digging had finished off; Langenwalter, 1992a: personal communication; see Figure 17). We also carefully trial off each of six "faces" (vertical stratigraphic wall profiles) which we then photographed and drew profiles (Figure 17). Unit 4 had been too severely disturbed prior to our work for us to discern any patterns there so we then reexamined the deposit below the foundation of the west wall of Classroom #4.

The historic debris, noted by the D.A.'s archaeologists as adjacent to Classroom #4, was referred to as a ". . . trash scatter [which] contained a mix of bottles, ceramics, tin cans, burned wood and bone" (Langenwalter, *et al*, 1985: p. 21; cf. Figure 6b, p.20). The similar historic material encountered by Hobbs and crew (see Section 1.3 above) was found by us to continue under the preschool foundation. The data we encountered from that point on constituted the remains of a tunnel (i.e. the data conformed to all of the test expectations of a tunnel as proposed by the project hypothesis; cf. Section 1.4 above). Those data are discussed in the next section.

#### 4.3 Location and Exploration of the Tunnel Under the North Axis of the Preschool

This section is based on the author's observations, the project notes, and the special notes made on the tunnel feature by Assistant Field Director, Don Flaherty. The historic debris noted above formed a pattern in the "side wall" of excavated soil below the foundation of the west wall of Classroom #4. We dug into this feature and discovered, in addition to miscellaneous cans and other debris noted above, two other severed roots (of 1—1.5" [2—4 cm.] in diameter, see Figure 7). These were found *in situ* precisely at the boundary of an opening whose "signature" was formed in part by the historic artifact debris in a matrix of disturbed soil (cf. Figure 19 below).

Just outside the upper right hand corner of the debris-filled matrix (which we later determined to be the tunnel), we also encountered what appeared to be a fire hearth. This feature consisted of spanish style roof tiles (red clay-ceramic) arranged around a center core of ashes and charcoal. Radiocarbon samples had been taken from the outermost reaches of this feature and submitted to the UCLA Isotope Laboratory for dating (cf. Section 5.1 and Appendix I.2 below). The arrangement was contained (and had possibly been emplaced) within the debris-laden fill at the top right corner of the roof of the opening (i.e. facing eastward toward the opening, the feature would be on the top and south corner). A tunnel entrance was thus well defined by the debris and fill contained within it.



The geologist consultant, Dr. Michael, had visited the site on May 8, 1990 and observed a disturbed feature with "artificial fill" at this same locus. He drew a diagram of the feature and measured its dimensions and location in relation to the west wall of Classroom #4 (see Figure 18a: note "af" on the diagram refers to the artificial fill within it). This feature was later determined by the archaeological team to be the entrance to the tunnel. Those measurements are as follows: the north side of the entrance was (at the bottom) some 3.1 m. (10.2') from the northwest corner of the preschool and the south side of the entrance was some 4.5 m. (14.8') from the same northwest corner. Hence the width of the entrance (at the bottom) was 1.42 m. (56"). Also the opening to the tunnel feature and its relation to a human form can be seen in Figure 18b. See Figure 19 for the tunnel entrance in relation to the preschool structure above it.

As we dug past the debris-filled opening and deeper under the preschool, we observed that the tunnel went in a sharp angle to the southeast. Continuing on, the feature intercepted Unit 1 (the trench-like unit) in Classroom #4 (see Figure 20b for a top view of the delineation of the entire tunnel feature). Coming out from under the concrete slab floor and in the open area of the Unit 1 Trench, the feature's nature became more clear. That is, the width and direction were not only clearly indicated by an abundance of historic artifacts contained within it, but also the soil color of the fill matrix was measured at 10YR 3/3, a quite "dark brown", which was distinctively darker than the surrounding natural soil matrix which had a lighter brown color of 10YR 4/3 ("brown to dark brown": Munsell, 1975). The historic artifacts found packed into the tunnel included sections of boards, wood fragments, a variety of metal objects, an inner tube and numerous bottles (the latter were analyzed for their possible dates, see Section 5.5 below). The average width of the tunnel feature was greater than 1.0 meter as it extended on the diagonal completely across Unit 1 (see Figure 20b) and under the concrete floor to the western edge of Unit 1. Other artifacts encountered as we were approaching the south end of Unit 1 included T.V. antenna wire, tin cans, scissors, eye glasses, exposed film, some cinder blocks, etc.

Proceeding southward, the tunnel continued to the south end of trench Unit 1 and obviously continued southward of that point. Indeed, the tunnel feature widened at one point (i.e. 50 cm. north of the south wall of Classroom #4) to the extent that it appeared less tunnel-like and more like a room. Also at that point we found a layer of plywood roofing material along with tar paper and roofing nails. This layer was found at the top of the tunnel fill material. Underneath the plywood and tar paper was a continuing abundance of bottles, wood and other debris. It became obvious that this densely packed debris-filled area was quite large in relation to the tunnel passage previously described. Figure 21a shows a view of the densely packed tunnel debris (note that the locus and direction of the photo are shown on Figure 20b drawing at point "A." Figure 21b shows a detail of the concentrated debris in the tunnel at point "B"). We then excavated out the historic debris of this area which not only extended to the south end of Unit 1 but also continued at least 1.4 meters (4.5') south of that point to the area under the doorway to Classroom #4 and the sidewalk corridor beyond and above. We measured the width of the debris-filled area from point C to C' (see Figure 20b) on a N/W and S/E line for some 2.74 m. (9'). See Figure 20c for a diagram of both subterranean features under the preschool.

FIGURE 18a: DRAWING OF ENTRANCE TO TUNNEL UNDER CLASSROOM 4  
BY DR. DON MICHAEL

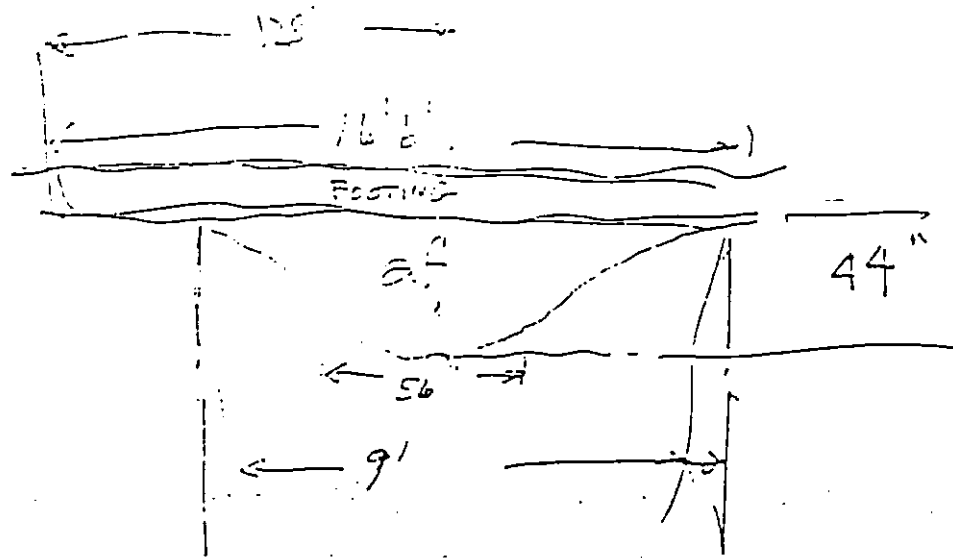

FIGURE 18b: VIEW OF TUNNEL ENTRANCE (Note person in entrance)







FIGURE 10a: MAP OF POSSIBLE TUNNEL FEATURE UNDER THE FRONT PART OF PRE-SCHOOL

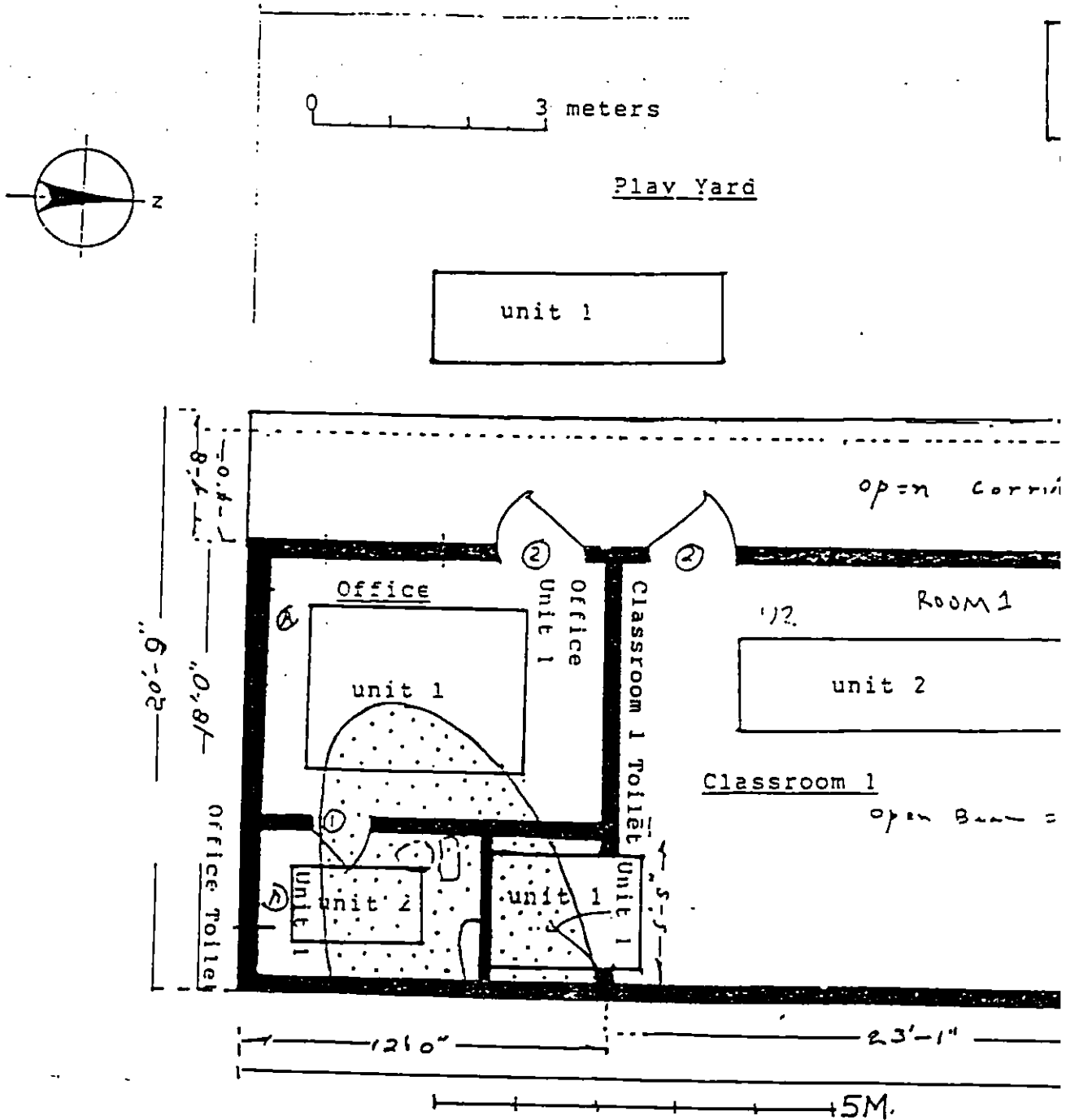
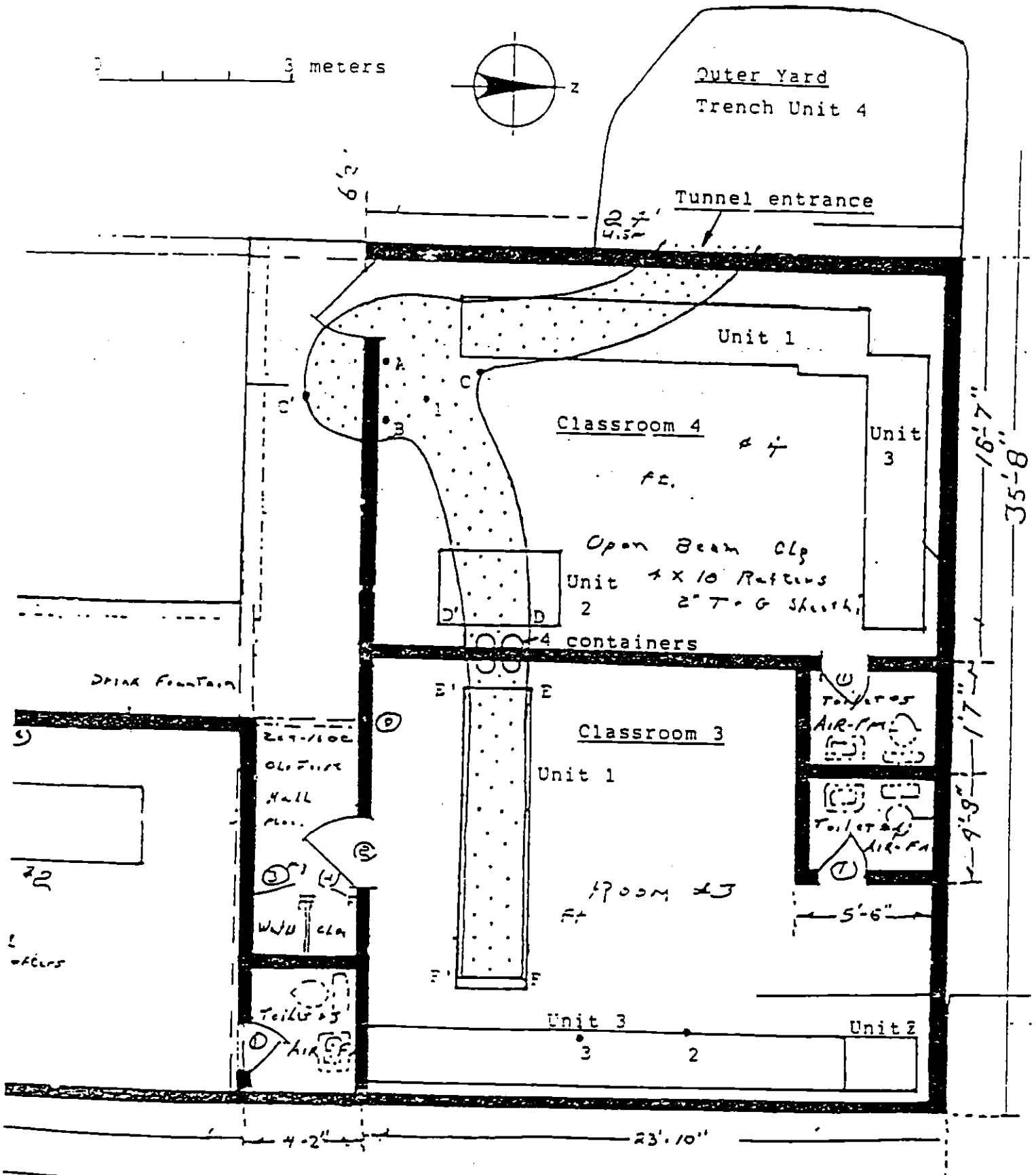
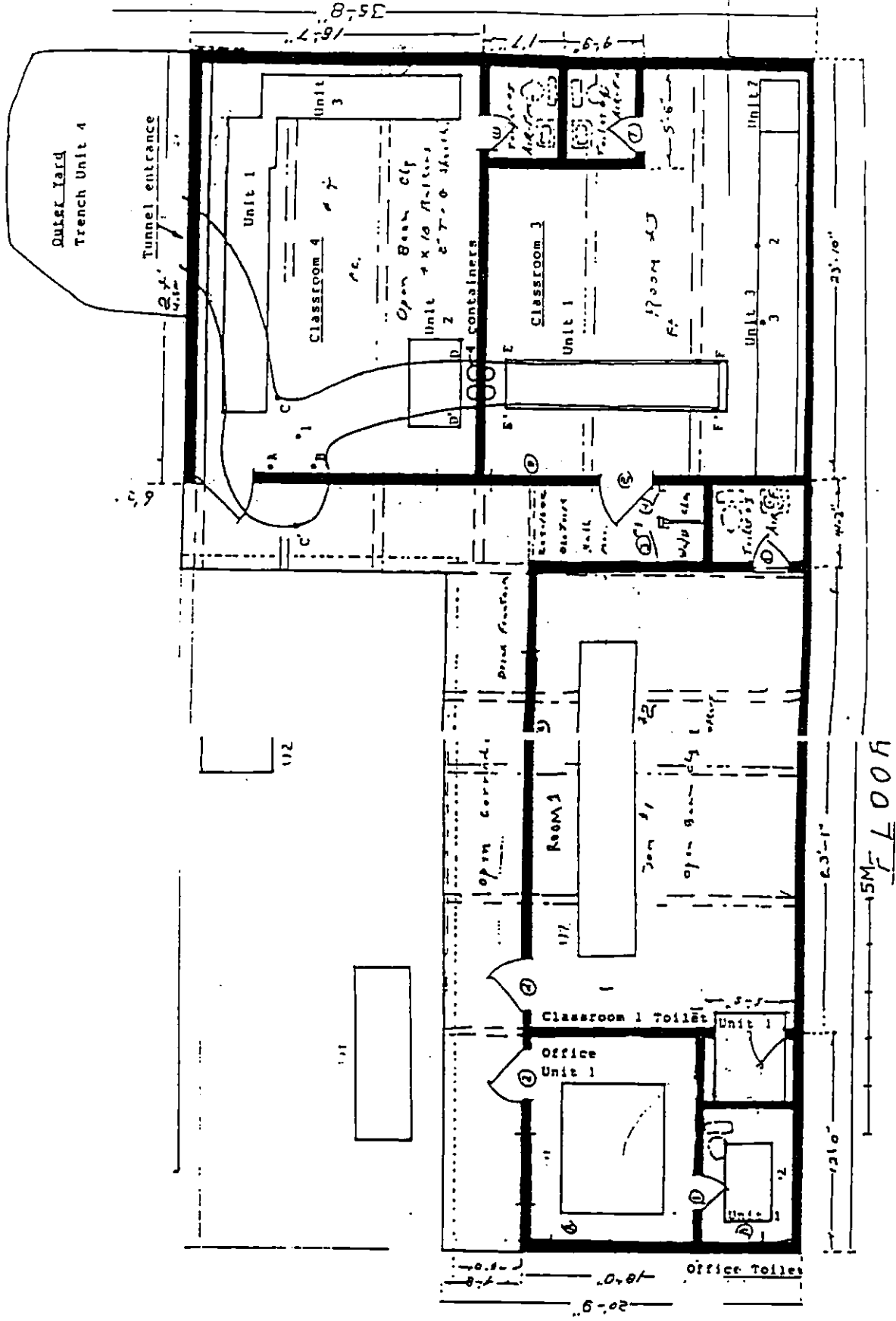

FIGURE 10b: MAP OF TUNNEL FEATURE UNDER CLASSROOMS 3 & 4



(see text for lettered & numbered point identifications)

UNIT 1 UNIT 2 UNIT 3 UNIT 4 UNIT 5 UNIT 6 UNIT 7 UNIT 8 UNIT 9 UNIT 10 UNIT 11 UNIT 12 UNIT 13 UNIT 14 UNIT 15 UNIT 16 UNIT 17 UNIT 18 UNIT 19 UNIT 20 UNIT 21 UNIT 22 UNIT 23 UNIT 24 UNIT 25 UNIT 26 UNIT 27 UNIT 28 UNIT 29 UNIT 30 UNIT 31 UNIT 32 UNIT 33 UNIT 34 UNIT 35 UNIT 36 UNIT 37 UNIT 38 UNIT 39 UNIT 40 UNIT 41 UNIT 42 UNIT 43 UNIT 44 UNIT 45 UNIT 46 UNIT 47 UNIT 48 UNIT 49 UNIT 50 UNIT 51 UNIT 52 UNIT 53 UNIT 54 UNIT 55 UNIT 56 UNIT 57 UNIT 58 UNIT 59 UNIT 60 UNIT 61 UNIT 62 UNIT 63 UNIT 64 UNIT 65 UNIT 66 UNIT 67 UNIT 68 UNIT 69 UNIT 70 UNIT 71 UNIT 72 UNIT 73 UNIT 74 UNIT 75 UNIT 76 UNIT 77 UNIT 78 UNIT 79 UNIT 80 UNIT 81 UNIT 82 UNIT 83 UNIT 84 UNIT 85 UNIT 86 UNIT 87 UNIT 88 UNIT 89 UNIT 90 UNIT 91 UNIT 92 UNIT 93 UNIT 94 UNIT 95 UNIT 96 UNIT 97 UNIT 98 UNIT 99 UNIT 100



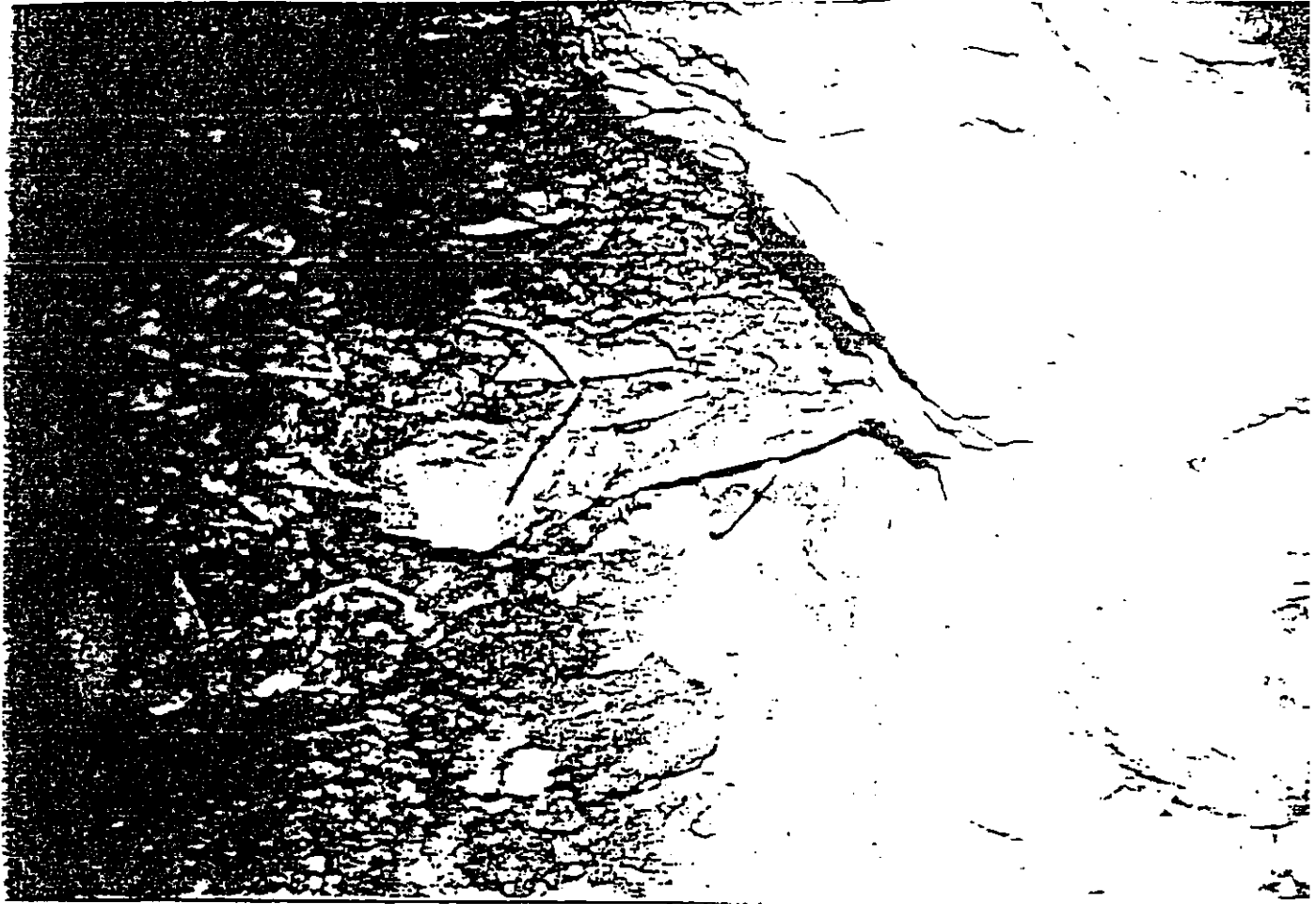

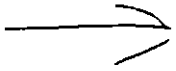
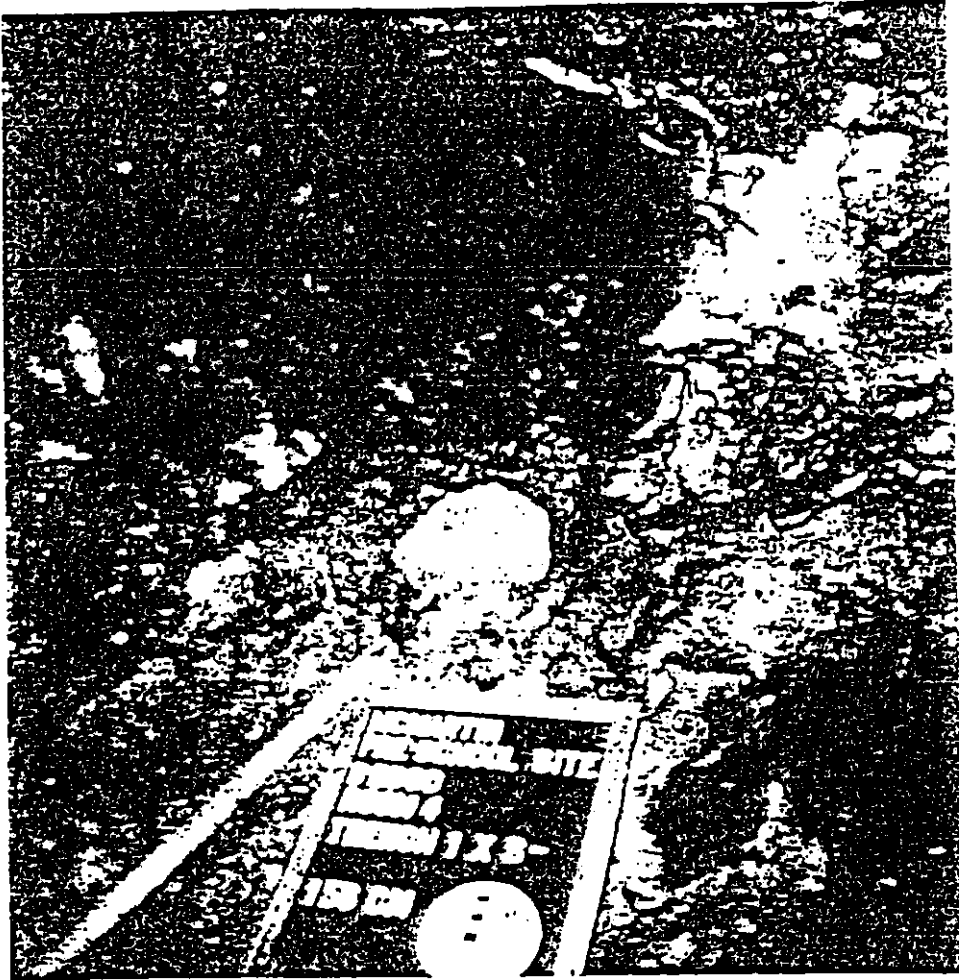

One major artifact, both in terms of size and potential import, was a complete rural, roadside style mailbox with a rounded top and a mail-for-pickup metal flag indicator (the actual flag was missing but the holder for the flag was present on the side of the box). The mailbox measured 48 cm. (19") long x 17 cm. (6.75") wide x 24 cm. (9.5") in height. This mailbox had the name "Mr. and Mrs. Karl Morris" and "927 M.B. Blvd." painted on one side, the same as the last occupants of the house on the adjacent lot that was torn down in 1972 (Figure 22a). On the other side was painted "Morris 927 M.B. Blvd." The mailbox door also was painted with "927 MB Blvd" (Figure 22b). This artifact was found in the east extension of Unit 1 (see Figure 20b, point 1) which placed it southeast of the southeast corner of Unit 1 and in the middle of the tunnel heading northeastward.

The depth of the tunnel in the room-like area was a little more than 2.0 meters (6'8") which would have permitted most adult males to stand upright. In contrast, the depth of the tunnel in the passageway leading from the west wall of Classroom #4 up to the room-like feature was more shallow, at an average of 1.80 meters (5'11"), which would have necessitated adults (especially most adult males) to bend over when walking through the passageway.

It was observed that the layer of plywood and tar paper, which may have served as a kind of roof for the room-like portion of the feature, continued in an arc to the east across the east side of the southeast corner of trench Unit 1 (see Figure 23). It appeared to slope southeastward as we followed it in that direction. This layer continued to a point 1.90 m. (6'2") north of the inside point of the south wall of Classroom #4. There were clear soil changes in the roof and floor and sides at point "C" (Figures 20b and 24). The overburden of soil forming the existing roof of the tunnel at that point was 54 cm. thick (measuring from the bottom of the concrete floor to the color and soil density change representing the former tunnel cavity). The thickness of the overburden roof under the doorway was somewhat thicker at 68 cm.

The nature of the walls of this wider area were inspected and it was observed that there were shovel mark "scars" on them. These "scars" indicated that the tunnel had been dug out with hand tools rather than mechanized equipment.

The direction of the tunnel from the wide room-like area appeared to change dramatically, turning from its southeast orientation to a "dogleg" headed acutely eastward (see Figure 20c). At this point the Principal Investigator was faced with an important decision, forced by the fact that there were only two days left for the excavation. Either the team should continue the excavation of all of the data still present in abundance in the room-like feature or continue to follow the tunnel in order to define its ultimate extent. Although important data may well have been missed by not fully exploring the "room," it was considered more important at that time to redirect our efforts to explore the extent of the tunnel. It was hoped that the more the tunnel feature could be defined, the more possibilities there would be for making correlations with the eyewitness reports of the children describing the tunnel(s), room(s) and artifacts.



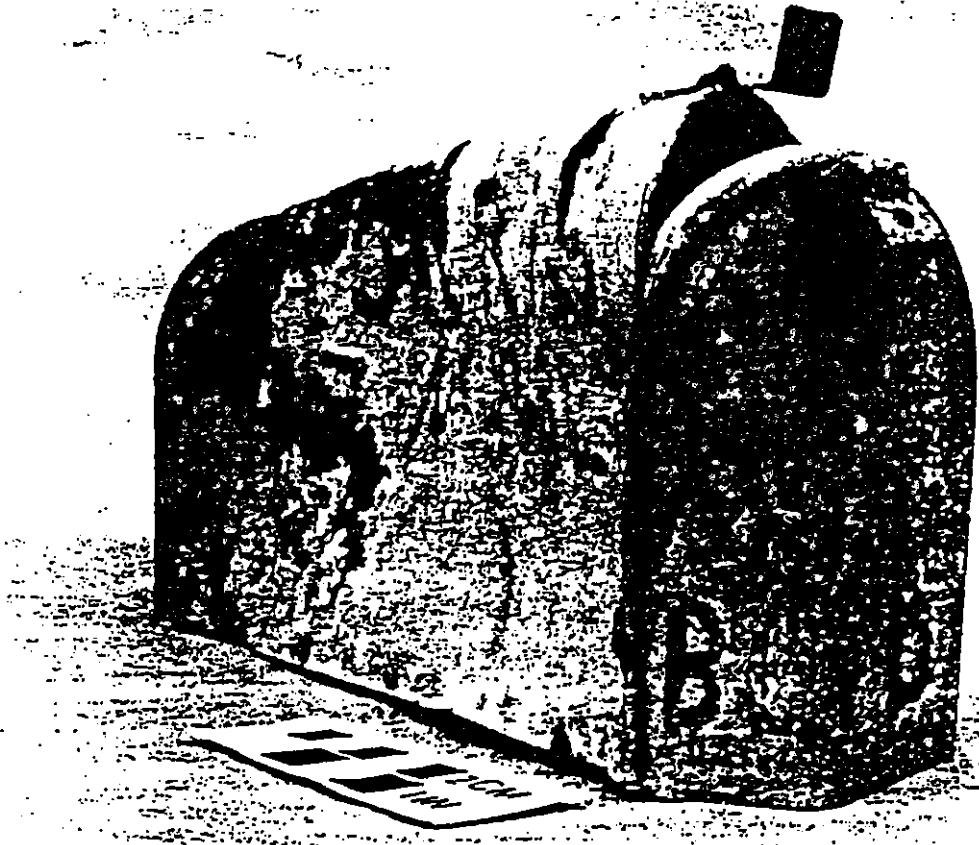
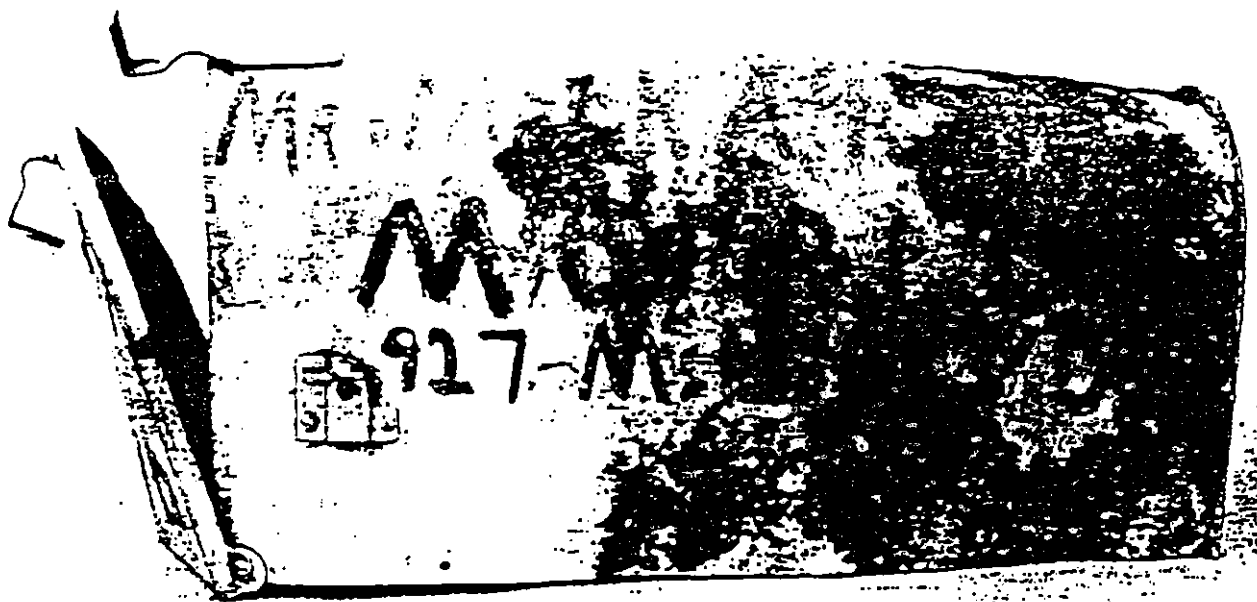
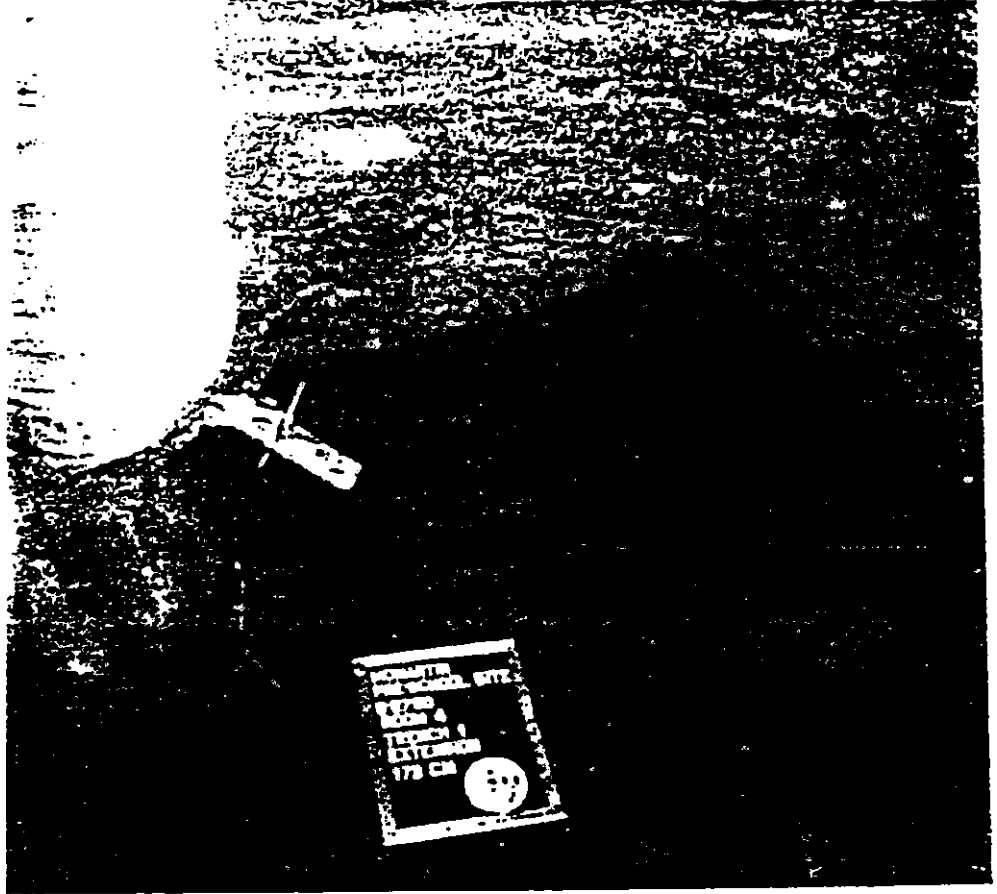

FIGURE 12b: SIDE VIEW OF MAILBOX



■ ■ ■ 2 CM  
■ ■ ■ 1 IN





Digging out the tunnel fill eastward under the concrete floor, it was apparent that the line of the tunnel (still indicated clearly by numerous artifacts and soil color and texture changes) continued across Classroom #4 and into the cut through the floor at Unit 2. The width of the tunnel between Units 1 and 2 in Classroom #4 was still about 1.0 meter (3.3'). The height of the tunnel feature was unlike the "room" area, returning to the 1.80 meter (5'11") average height of the western passageway (cf. Figure 20b). The tunnel feature was clearly discernible in Unit 2. Some boards and a few tin cans were still found in the tunnel fill within Unit 2 but they petered out until no more major artifact inclusions were encountered at about three fourths of the way (80 cm.: 31.5") across the Unit (see Figure 25).

Later laboratory tabulation of these data disclosed that a total of 1603 artifacts were recovered from the tunnel. These were distributed from the entrance through the southeast passageway to the room-like area and from there to Classroom #4, Unit 2. Most of these artifacts came from the larger room-like area. What were considered to be possible diagnostic artifacts that might be directly datable (i.e. with a date stamped or marked on them or which might have other markings such as U.S. Patent Marks that might yield an age) were submitted to the project's Historical Artifact Analyst, Jeff Minard. It was hoped that some of the bottles, cans or other finds might yield dates that would indicate the date of the construction, use and/or abandonment of the tunnel (e.g. the time of its filling with soil and debris). Mr. Minard's analysis is presented in Appendix I.5.

At that point (three-fourths of the way across Classroom #4, Unit 2), a decision was made to dig out the overburden above and dig out the rest of Unit 2 to that point in order to see the vertical face or profile of the tunnel feature. It should be noted here that it is much easier for an archaeologist to see or detect a tunnel or a similar structure by cutting a cross section of a soil deposit perpendicular to the possible orientation of the tunnel. Given the test expectations noted in Section 1.4 above, if a tunnel had been back filled with soil and other materials or objects, that material would help to form the "signature" of the tunnel, since that fill should be softer, less compact, should be of a different color (particularly if the soil were brought in from another, off-site source), and it might contain atypical artifacts and ecofacts. Such was the case with the tunnel feature, which can be clearly seen in Figure 26 at point D to D'(cf. Figure 20b). The tunnel outline was clearly visible with the fill of darker and lighter colored layers, cracks indicating different layers of fill, roots (visible at the upper right hand corner of the provenience board, and ecofact inclusions of small stones (appearing as white specks in the photograph). There was no large historic artifact trash (bottles, cans or large pieces of wood for example) contained within the tunnel fill at that point. Also note in the photograph (Figure 26) that the non-tunnel and naturally formed deposits of soil outside the tunnel are lighter in color generally and are devoid of the other disturbance elements noted above.

When the rest of the tunnel fill and the overburden above were excavated eastward, it was noted that the tunnel feature ran completely across Classroom #4, Unit 2 up to the foundation under the dividing wall (see Figure 27). Also the overburden "roof" above the tunnel gradually diminished as the tunnel came closer to the surface until, at the point where the tunnel went under the concrete foundation, there was no soil overburden or roof. Consequently the bottom of the foundation intruded into the tunnel's roof at that point.

FIGURE 10: SECTION OF THE TUNNEL AT THE  
UNIT 2, WEST ENTRANCE Note slight arch on bottom of  
foundation:

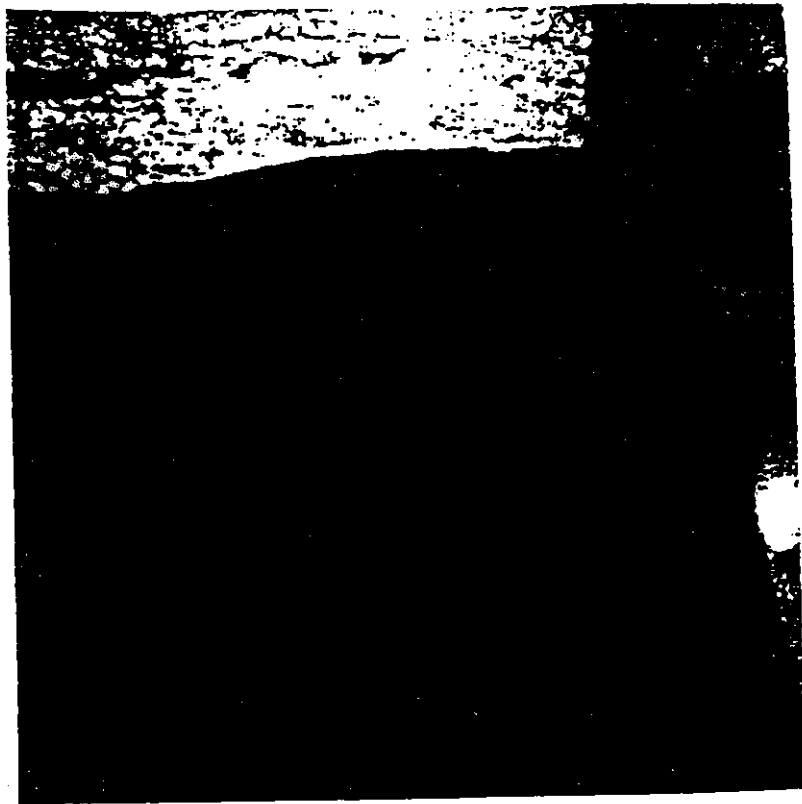



FIGURE 17. VIEW OF TUNNEL NO. 27 PASSAGE UNDER SLIGHTLY  
AROUND CORNER OF OVER CLASSROOM 2. LOOKING east.



Curiously, it was observed that at the precise width of the tunnel, at the point where it crossed under the dividing wall between Classrooms #4 and #3, the bottom of the concrete foundation was slightly arched (see Figure 27. cf. Figure 25). The considerable depth of the foundation (as measured at the centerpoint of the tunnel passage) was 63 cm. (24.8") below the concrete floor. The depth of this foundation (which gave it enormous strength) is curious given that it supported only a structurally insignificant secondary dividing wall between the two classrooms.

We then acknowledged the fact the our initial Ground Penetrating Radar survey had actually detected the tunnel at the locus of its crossing under the dividing wall (see Figure 12). Indeed, the GPR was successful in detecting the tunnel feature on both sides of the dividing wall beneath the concrete pad floor. The two corresponding anomalies had been the reason we decided to cut through the concrete pad floor to create Classroom #3, Unit 1 and Classroom #4, Unit 2 in the first place. And it was the reason the two units were directly aligned with each other, even though on opposite sides of a then-existing dividing wall.

Next an extension eastward was excavated in order to follow the tunnel's path. An unexpected discovery of four large artifacts was made in the tunnel directly under the foundation between Classrooms #4 and #3. These were four large containers (Figure 28). All four containers were found *in situ* standing upright and directly beside each other (note their position in Figure 20b). Curiously, they were not found on the floor of the tunnel but had been placed on a *de facto* "platform" of fill halfway down. All of the containers were placed with their openings facing upward.

The four containers were comprised of two blue enameled metal cylindrical pots; one tall, contoured, cylindrical crockery pot; and one rusted cast iron caldron (Fig. 28). The caldron originally had an iron handle which we found to be missing. The caldron's surface was found in a highly rusted state both inside and out (Figure 29). It measured 78 cm. (30.75") in maximum circumference at the top, and 47 cm. (18.5") at the rounded bottom. The pot had a diameter of 26 cm. (10.25") at its top. It was 22 cm. (8.75") in height. The smaller of the two other metal pots had a loose, makeshift handle of twisted wire fixed around its circumference. This vessel had a circumference of 101 cm.(39.9") top and bottom (Figure 30c). Its diameter was 34 cm. (13.4"). The vessel was 27.3 cm. (10.75") in height. The larger of the containers, (Figure 30a) had large patches rusted off its graniteware stippled blue surface. The circumference was 114 cm. (45.1") top and bottom, and its diameter was 37.5 cm. (14.75"). The height of the pot was 35.7 cm. (14.2 in). The larger metal pot had one original looped metal handle still fixed to one of its sides. The corresponding handle on the other side had been broken off.

The crockery container (Figure 30b) was stamped "Red Wing Stoneware Co.", was of a glazed tan color and had a decoration of one cobalt blue leaf and three stems painted on one side. The pot had a circumference of 74.5 cm. (29.35"), top, and 74 cm. (29.25"), bottom. The diameter of this vessel at the top was 23.4 cm. (9.25"). This container did not have a free handle on it but handle-like lugs were molded into its sides under the rim (see Figure 20 for the location of the containers; and see Figure 28, which shows a reconstruction of how they were placed with one another under the foundation).

FIGURE 25: RECONSTRUCTED POSITIONS OF THE 4 DEBRIS FILLED CONTAINERS FOUND ALL UPRIGHT IN THE TUNNEL BELOW THE FOUNDATION BETWEEN CLASSROOMS 4 & 3 LOOKING EASTWARD



FIGURE 29: IRON CALDRON AND CONTENTS





FIGURE 101a: LARGE ENAMELLED METAL CONTAINER

FIGURE 101b: CROCKERY CONTAINER AND CONTENTS



2 CM

1 IN

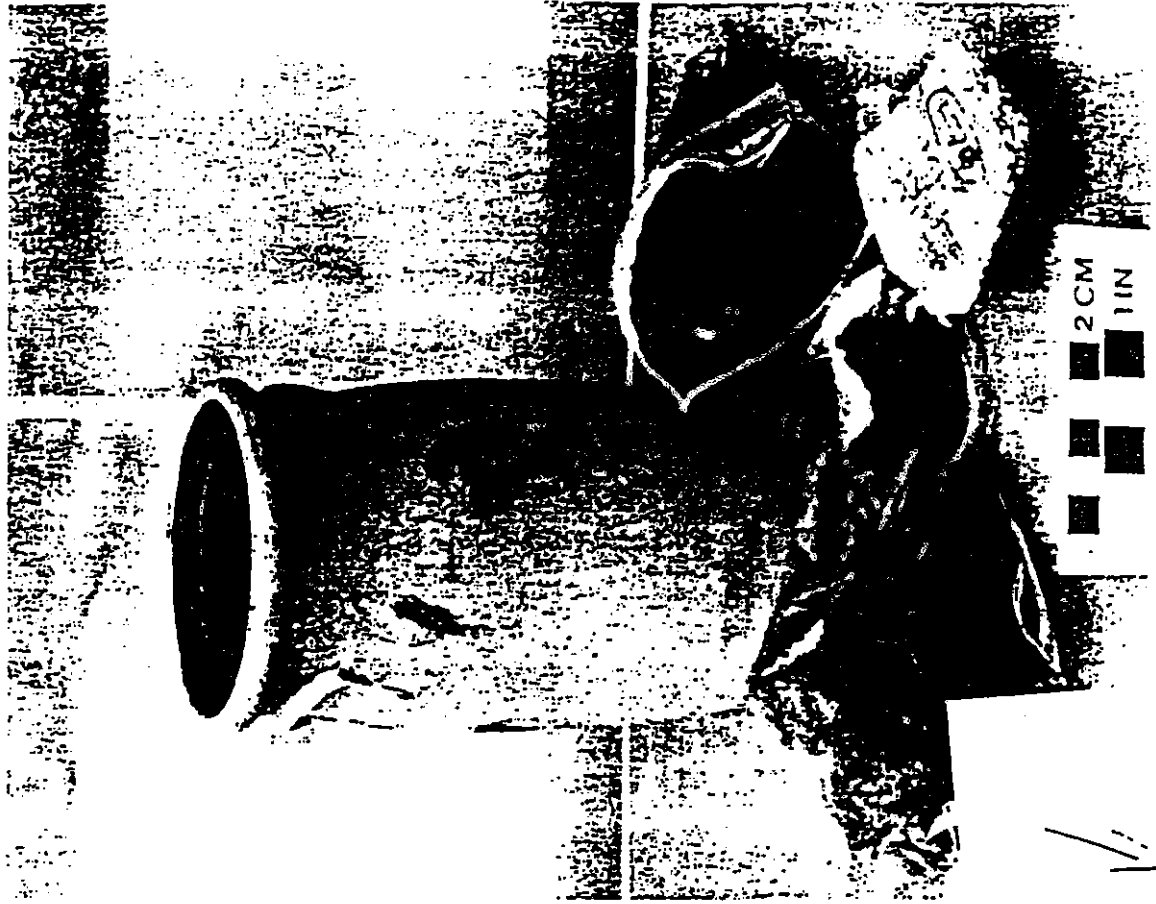

2 CM

1 IN



FIGURE 306: TALL METAL CONTAINER AND CONTENTS



All four containers were found filled with a great deal of trash (Figures 30a-d). The cast iron caldron was filled mainly with soil but it did contain 2 metal fragments, a piece of black yarn and 2 large fragments of an ocean shell (wavy top shell, *Astrea undosa*, Figure 29). The smaller of the two blue enameled metal pots contained a large fragment of a soft drink bottle, 60—80 miscellaneous metal fragments, 3 light green-painted cinder block fragments, and one small bone china pot lid (Figure 30c). The larger of the two cylindrical blue metal pots contained one large 1 gallon glass food jar (found completely unbroken), 35—40 old rusted tin can fragments, one 15 cm. (diameter) crockery lid, one old medicine bottle, 30—33 glass fragments from a large jar, one small, pestle-like stone and one 43 cm. (17") rusted metal rod (Figure 30d). The tall crockery pot contained 1 chunk of concrete (15.5 x 13 cm.) and 60—70 rusted metal can fragments (Figure 30b). All items were packed with soil in each container.

Further work revealed that the tunnel ran completely under the dividing wall foundation and eastward under Classroom #3. The bottom of the wall foundation, the arched portion, served as the roof of the tunnel at that point (i.e. there was no intervening compacted soil roof). Figure 31 shows a view of the tunnel cleared of its fill and debris, looking from points C-B to E-E' (note the roof of the tunnel is visible in the foreground above the debris). We then excavated an east extension of the Classroom #3 trench-like Unit 1. Digging downward, it was then possible to observe a profile of the tunnel feature. The bottom of the tunnel was slightly U-shaped and clearly distinguishable from the lighter natural soil matrix below (which, unlike the tunnel fill, contained some lighter and darker-colored small areas of rodent burrow disturbance). In Figure 32a (at points E-E'; cf. Figure 20) we see Jerry Hobbs sitting on a platform-like level that we created by removing the fill down to that point. Therefore he is sitting halfway down the vertical extent of the tunnel. The bottom of the tunnel is clearly visible boundary between the darker tunnel fill and the lighter natural soil matrix below (see the indicative marker on Figure 33).

Just 20-30 cm. (approximately 12") eastward of the dividing wall foundation, another profile was defined. The tunnel at that point again had a "roof" of compacted overburden soil. Therefore a U-shaped soil boundary was observable on the top of the tunnel profile. It was very clearly defined both in soil color and texture.

Unlike the tunnel passages in Classroom #4, we found virtually no inclusions of artifacts in the tunnel fill within Classroom #3. Following the tunnel fill, we reencountered the area of the metal pipeline with the shiny pipe joiner clamps previously described (see Figure 13 b and 36a below; note this pipeline can be seen in Figure 32b in the foreground as well). A hypothesis about the clamps was then formulated and they were submitted to the Historic Artifact Analyst (see Section 5.5 below). As we continued to follow the tunnel fill eastward down trench Unit 1, it became apparent to us that the original tunnel virtually coincided with the size and length of our concrete cutout for that unit. This coincidence was the reason we did not discover the tunnel previously when we were digging Unit 1. It had been virtually impossible to distinguish the tunnel as we dug downward, precisely within its margins. And the reason for the coincidence was that we had detected the tunnel passage underneath the dividing wall between Classrooms #3 and #4 (by Ground Penetrating Radar) and our trench Unit 1 cutout in Classroom #3 just happened to fall directly on top of the tunnel alignment.



FIGURE 306: TALL METAL CONTAINER AND CONTENTS

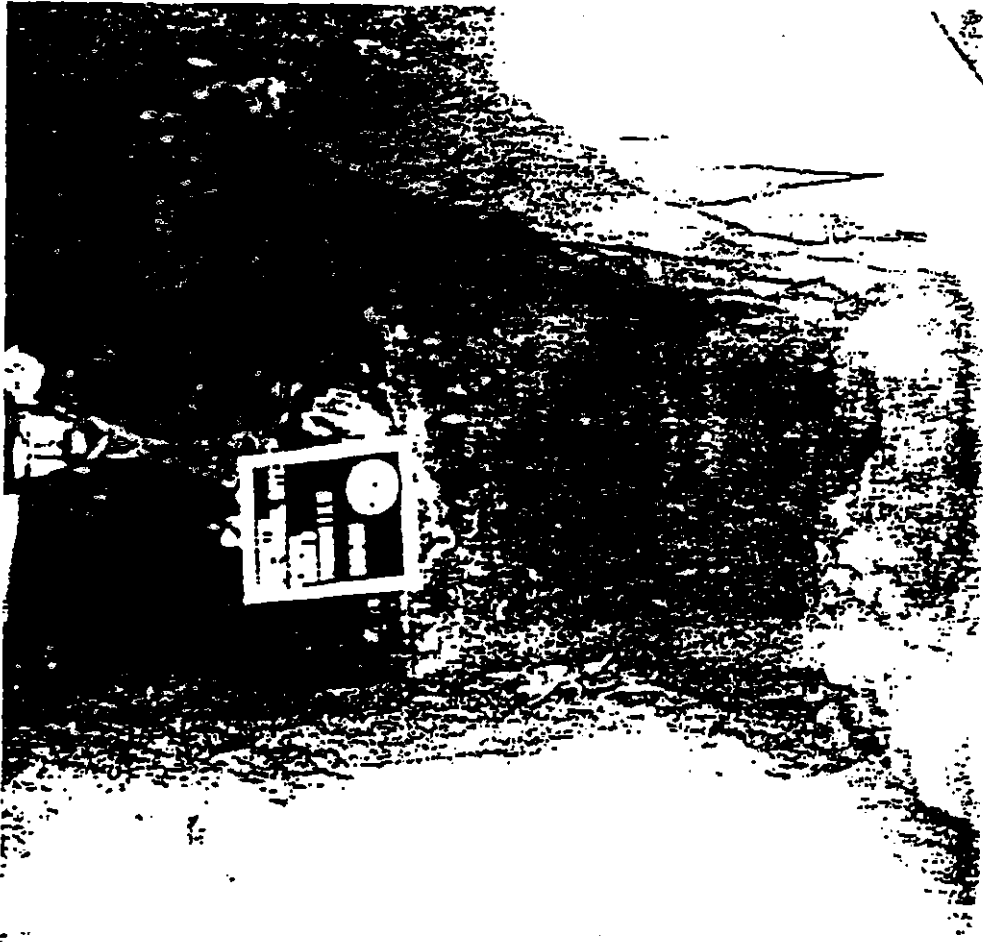

FIGURE 11. VIEW THROUGH THE TUNNEL LOOKING EASTWARD FROM  
FOOTING OF THE EAST END OF TUNNEL.

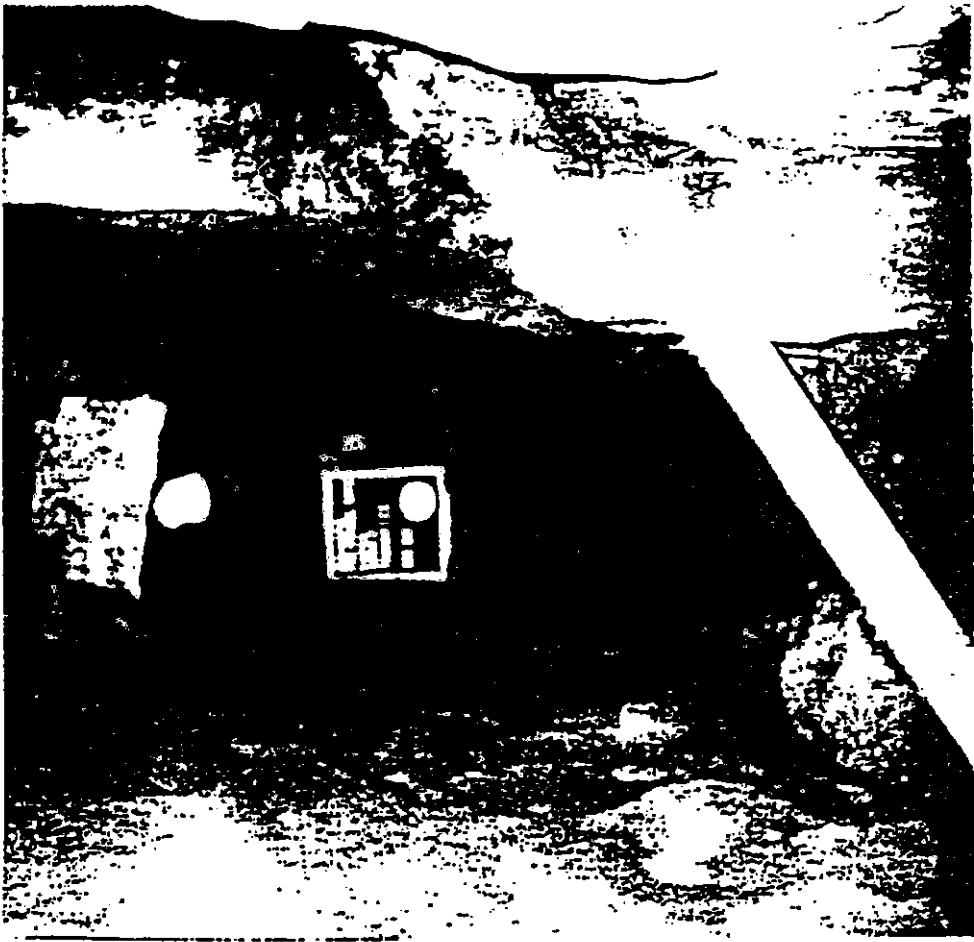

FIGURE 32.7 VIEW OF J. DOBBS KNEELING ON EXCAVATED LEVEL, HALFWAY DOWN TUNNEL, FILL, LOOKING BACK WESTWARD AT POINT E-E'

32a: (Note Tunnel signature)



32b: (Note same view but with pipe in foreground, cf. Fig. 14b)



Due to the critical lack of time (It was now Friday, May 25; only the Memorial Day weekend remained after several extended deadlines), the decision was made to have some workmen dig in various places on the site in order to create profiles, in the hope that we might inspect them and find some signatures of possible tunnels or rooms. These workmen dug along the entire east wall of Classroom #3, thereby digging between Unit 2, passing by Unit 1 and continuing to the south corner of the room. This trench was designated as Unit 3 (see Figure 20). They also started to dig down Sector 4 of Unit 1. We stopped them as soon as it became apparent where the tunnel was leading. We then decided to do a profile of the bottom of the tunnel at points F-F' (see Figure 34a and 34b). This point was located most of the way across Classroom #3, and was only some 1.70 m. from the east wall of Classroom #3. The bottom of the tunnel here was also U-shaped and its signature, based primarily on soil color, was clearly visible (see Figure 34a & 34b). In Classroom #3 the tunnel appeared to be about 1.5 m. (4.9') in height and it varied from 1.0 to 1.5 m. (3.3 to 4.9') in width. It was unfortunate that we could not detect the further continuation of the tunnel at that point due to the workmen's hasty removal of the vital soil deposits between the east end of Unit 1 and Unit 3.

Summarizing the excavation under Classrooms #3 and #4, we were able to find a clearly defined tunnel whose data conformed to virtually all of the test expectations we developed for the discovery and identification of such a tunnel. Indeed, we were able to follow the orientation of the tunnel for some 6.75 m. (22.2') in Classroom #4 and for an additional 8.5 m. (27.9') where it went in an east/west direction across Classrooms #4 and 3 until we could follow it no further. Thus we followed the tunnel for a total of at least 15.25 m. (50') through both Classrooms (including the area of the possible room under the doorway area of Classroom #4).

Once we knew what we were dealing with, we stopped the workmen and more carefully explored what remained in Unit 3 of Classroom #3. Within it we were able to detect some remains of upright wooden posts. These were found *in situ*, still in upright positions. Both posts were the remains of 4 x 4" timbers. The first one had been burnt and was located some 2.4 m (7.9') from the north wall and 1.0 m. (39.37") from the east wall of Classroom #3, at a depth of 2.08 m. (6.8'; Figure 20, Classroom #3, point 2). The second post was more intact, and only slightly burnt. It was located 3.8 m. (12.5') from the north wall and 85 cm. (33.5") from the east wall of Classroom #3 and at a depth of 2.1 m. (6.9'; see Figure 35). Due to their relationship parallel to the east wall of the preschool and relative to wood fragments to the north in Unit 2 found by Hobbs (see Appendix IV.1). These posts seemed to be spaced at regular intervals, going from north to south in classroom #3. (see Figure 20, Classroom #3, points 2 and 3 for their spatial locations). They may have been part of a shoring system for an underground passageway, but we could not explore for corroborative evidence at the time. The geologist later provided the author with a report based on an electrical resistivity survey in which a possible correlative underground feature was detected in that area (see Appendix I.3b).

This was the final work of our excavations at the site.

FIGURE 31a. VIEW OF TUNNEL SIGNATURE IN  
CLASSIFICATION 3 AT POINTS 1-4

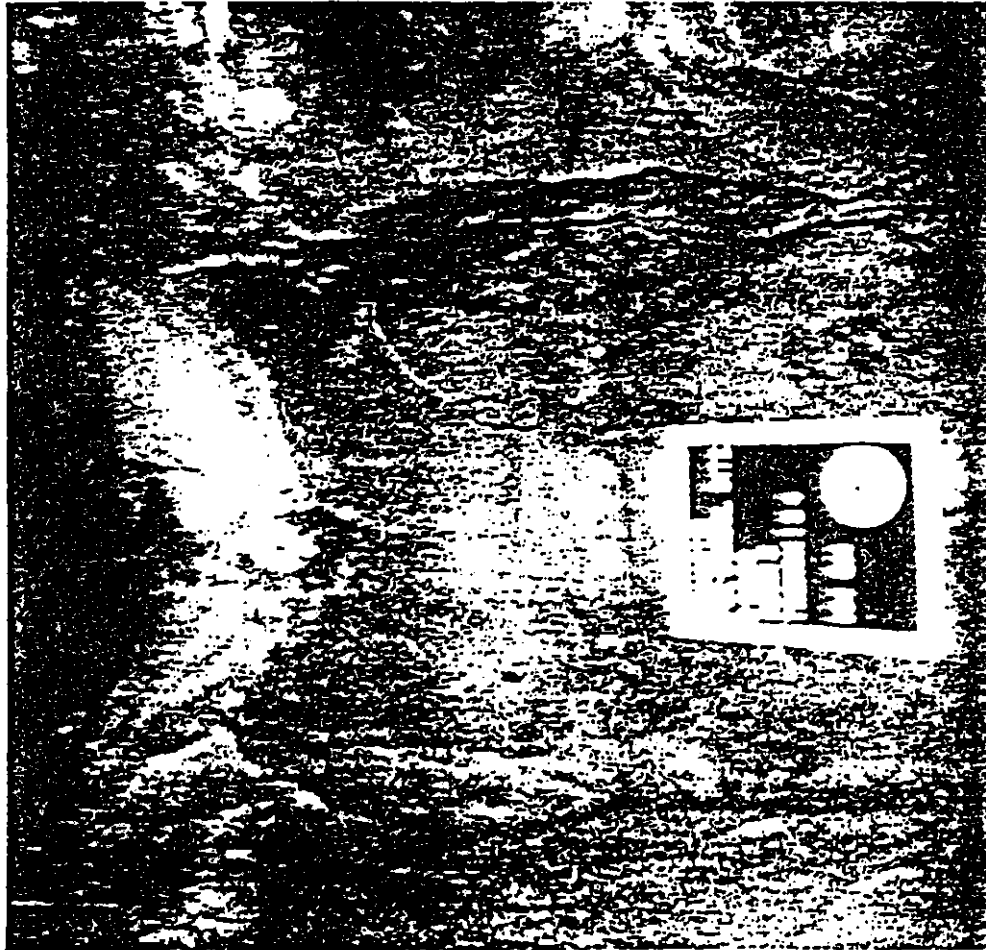

31b. DETAIL OF BOTTOM OF POINT 1 AT  
POINTS 1-4

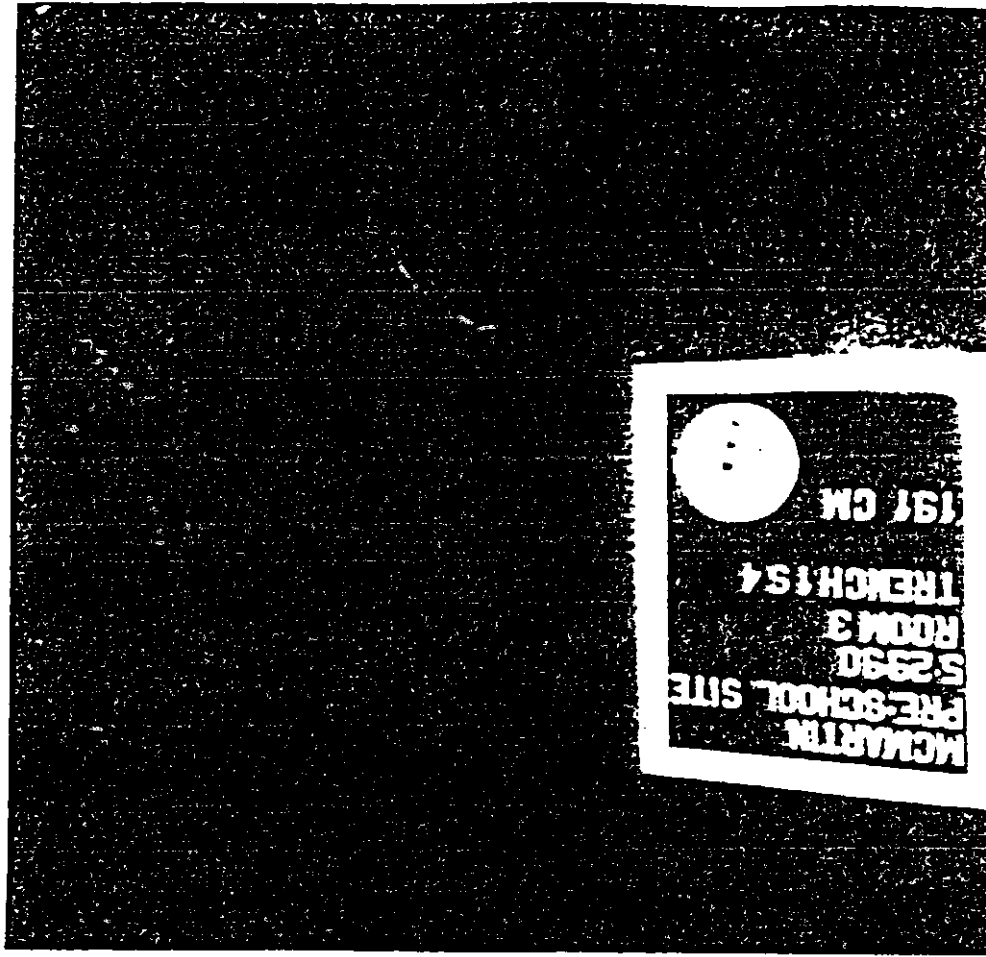







4

## 5.0 Ancillary Supporting Scientific Analyses by Consultants

### 5.1 Introduction of Supporting Scientific Team

The project drew on a number of consultants who provided scientific input based on their own specializations in archaeology or related scientific fields. The following is a brief discussion of the results of each of the scientific team member's results. Their respective reports are included in Appendix I. The first report is based on the work of Prof. Rainer Berger, who performs chronometric dating, especially on archaeological data by radiocarbon assays. Next follow the reports of Dr. Don Michael, site geologist; Dr. Charles Schwartz, faunal analysis; Minard, historic special artifact analysis; Hellman, electrical "fire alarm" assessment; and the results of the Ground Penetrating Radar survey. The results of these various support studies will be integrated into the project findings in the next Section, 6.0.

### 5.2 Radiocarbon Analysis

Prior to the writer's May 2, 1990 involvement with the project, Gunderson collected two charcoal samples for radiocarbon dating on May 2, 1990. These samples were taken from among charcoal pieces immediately surrounding the "fire hearth" feature located in the upper right corner (facing the west wall of Classroom #4) of the entrance to the tunnel. They were given provisional provenience numbers of "TLG" No. 223 and No. 227. The two samples were submitted to the UCLA Isotope Laboratory for radiocarbon dating by its Director, Prof. Rainer Berger.

The results of the radiometric analysis indicated that the tree(s) from which the charcoal samples derived were probably not more recent in age than the 1930's (see Appendix I.2 for Prof. Berger's report).

It should be understood that Gunderson submitted the samples in good faith prior to the author's involvement with the project. Radiocarbon dating should not be expected to yield useful results to the project since the era in question (1980—1989, i.e. any possible activity in tunnels or rooms prior to the time of our excavation) was too recent in time to be effectively measurable by radiocarbon. Other dating systems, most probably dates on found artifacts, would be better age-date determiners.

### 5.3 Results of the Geological Study of the Site

Consulting geologist Dr. Don Michael reports that the entire Manhattan Beach area is underlain by ancient dune sands that date within the last 10,000 years (known as the Holocene or Recent Epochs). At the preschool site itself, he observed two deposits of soil: "...an older filling episode over a slope that originally extended downwards to the north on the northern side of Manhattan Beach Boulevard, and a local younger episode of filling that was apparently undertaken for the construction of the school building" (Appendix I.3a).

Although he provides data showing that the sand deposits at the preschool site are compacted, he still notes that "To be safe, it (a tunnel) would have required shoring, i.e., some sort of support for its walls and ceiling, because the dune sand, even as well compacted as it is, would cave in if it became too damp".

Dr. Michael also provided a drawing (Figure 18a) and measurements of a feature he described as a cavity. This feature was located under the foundation of the west wall of Classroom #4. Although initially discussed in a 1992 correspondence to the author (Appendix I.3a), upon an inquiry seeking clarification of his report, Dr. Michael now reports that the feature was a "cavity" which contained "af", that is "artificial fill" that had been emplaced ". . . due to the operations of man. . .". He reports that the cavity could have been formed in three ways:

- (a) it could have been excavated, i.e., created by the removal of material that previously occupied the volume of the cavity;
- (b) it could have been left as a result of the incomplete filling of a previous, larger cavity such as a tunnel excavation;
- (c) it could have formed as the result of the caving of an underlying cavity. (Michael 1992b: 2; Appendix I.3b).

Concerning his most recent thoughts on the age of the feature, Dr. Michael states:

My notes indicate that the wrapper (The Disney bag found within the cavity just under the foundation of the west wall of Classroom #4) was a plastic bag imprinted with cartoon characters and bearing a copyright symbol and date of 1983. Therefore the cavity could be no older than 1983, assuming the Disney Corporation did not manufacture a wrapper prior to the time of the copyright date appearing upon it. Even if it did, it probably would not have done so much before 1983 and certainly not as early as 1966 when the McMartin School building was constructed (Michael 1992b: personal communication: cf. Appendix I.3b).

It should be noted here that Dr. Michael defines the "cavity" as the volume of the artificial fill. Therefore, while the time of filling the cavity would be no earlier than 1983, the cavity to be filled could have existed for any duration before 1983. The author's interpretation is that the Disney bag may date the time of the filling in of the tunnel feature under the northern E/W axis of the preschool, not the time of the construction of the tunnel (although the time of construction probably postdates 1966; cf. Section 4.4 above and Section 7.0 below).

The author was unaware (until a June, 1992 phone conversation with Dr. Michael) that Dr. Michael had run his own remote sensing survey for the project. The technique used was electrical resistivity (cf. Hester, Heizer and Graham 1975, pp. 21-22). A colleague of Dr. Michael, Dr. Herbert Adams, of the Geology Department of California State University, Northridge, ran the instrument in a survey on a traverse between the north wall of the preschool and the house immediately to the north and parallel to that axis. The survey generated an electrical resistivity profile based on values measured in "ohm feet". When plotted, the values indicate "...an anomalous increase in resistivity" (Michael, 1992b: p. 3), at a point parallel to the east wall of the preschool and at a depth of 10—15 feet (3.04—4.6 m.). Dr. Michael interpreted this anomaly as having a signature indicating

"...presumably, a cavernous zone..." (Michael 1992b: 3; cf. Appendix I.3b). These findings corroborate our interpretation of a possible tunnel feature along and under the east wall of Classroom #3 (see Section 4.4 above).

#### 5.4 Results of the Zooarchaeological (Faunal) Analysis

Dr. Charles Schwartz, a specialist in archaeological animal bone identification and analysis and a longstanding member of the ERA Consortium, first analyzed some 22 bones that were recovered by the preliminary digging by Hobbs and crew prior to the ERA team's formal archaeological excavation. All of these bones were found during their digging and exploration of the area we later designated as the Outer Yard Trench Unit 4 (see Figure 11). Unit 4 was the irregular pit located beside the west wall of Classroom #4. Some of the bones came from the outermost part of the fill of the tunnel entrance just east and inside the wall line of the Classroom.

The 22 specimens were identified as domestic cattle (*Bos taurus*); chicken (*Gallus dom.*); probable domestic cattle, unidentified; and domestic pig (*Sus scrofa dom.*). Two bones (433 and 483B; note these numbers were previously assigned and are separate from the ERA catalogued, numbered specimens) were possibly of domestic dogs. None of these bones exhibited evidence of trauma that would indicate the animal had suffered a violent death (see Appendix I.4).

In addition, Dr. Schwartz analyzed some 77 bones found during our formal excavations at the site. Of those identifiable, most (50%) came from large domestic animals, 11% from domestic chicken and 10% from wild species. Specifically, there were 19 bones of domestic cattle, 19 of domestic pig and 2 from domestic dogs (*Canis familiaris*). In addition, there were 5 bones from unidentifiable birds, 9 from chickens, 1 rabbit (*Sylvilagus*), 1 rodent, 1 reptile, 1 from a large unidentified mammal, and 19 other unidentifiable bones. There were no trauma-related marks or modifications observed on these bones. The marks that were present were consistent with modern butchering techniques. Indeed, the faunal assemblage is consistent with food remains. The 1 rodent bone was probably a wild rodent (e.g. possibly a ground squirrel) whose remains were fortuitous at the site. Dr. Schwartz noted that:

... the occurrence of these bones within the context of the yard and trenches is unusual. It is unlikely they occurred randomly, [also] the elements recovered from the different animals are uneven in their distribution, no teeth or skull material, no pelvis specimens and only a few carpal bones. . . . From most archeological contexts this sample would be considered atypical of kitchen midden material (see Dr. Schwartz's report in Appendix I.4).

#### 5.5 Results of Selected Special Artifact Analysis

A selected number of artifacts were sent for special analysis by the project's Historic Artifact Analyst, Minard. Thirty seven (37) complete bottles and jars found within the main tunnel were carefully inspected with a primary objective of determining their actual or probable dates so that the tunnel, or at least the time of the filling in of the tunnel, might be dated by their association. Most of the items were whole specimens, but some were recovered in a broken state and yet were complete enough for identification. Each item was measured, and notes on any embossing, painted labeling, and other comments

deemed relevant were taken. The artifacts consisted of a number of drinking glasses, medicine bottles (a variety of medicine and eyedrop containers), food bottles (beer, soda, preserves and salad oil bottles), condiment bottles and jars (mustard and sauces), cosmetic jars (a cold cream jar), household utility jars (shoe polish jars), and household decor items (vases)(cf. Appendix I.5).

All of the glass containers identified range in age from the 1920—1960 era, with most of them dating to the 1930's—1940's era. Thus none of these data would date the fill to a time after the 1966 construction date of the preschool.

The metal strap pipe connectors, found on the pipe leading to the toilet in Classroom #3 , Unit 1, sector 2: (whose *in situ* provenience placed them within the main tunnel at that point; see Figure 13b) were investigated as a special find by Jeff Minard. The connectors are technically known as Pipe Joint Clamps. They were manufactured by the Anaco Company of stainless steel. A U.S. patent for this specific design was granted on February 8, 1966 (cf. Appendix I.5, Attachment 3). This clamp is still being marketed by the Ideal Corporation of Florida. An executive of the Corporation was queried as to the likelihood that the two clamps could have been purchased and installed on the pipe in Classroom #3 by September, 1966 (the date of the construction of the preschool). The response was that it would have been "unlikely," that is, it is most likely that the clamps would have been purchased and installed after the preschool's construction (Appendix I.5). Thus the clamps probably date to a time after 1966.

Figure 36a shows the two pipe joint clamps. Figure 36b shows two other clamps. Both of these artifacts (MP563 found in Office, Unit 1; and MP562 found in Classroom #2, Unit 1) have considerable more corrosion and patina than the two connectors (MP560 and MP561) found within the tunnel on the pipe to the bathroom in Classroom #3.

See Appendix I.5 for the full historic artifact report.

FIGURE 36a RELATIVELY NEW LOOKING PIPE CLAMPS FOUND IN CLASSROOM 2, WEDDIN BUILDING

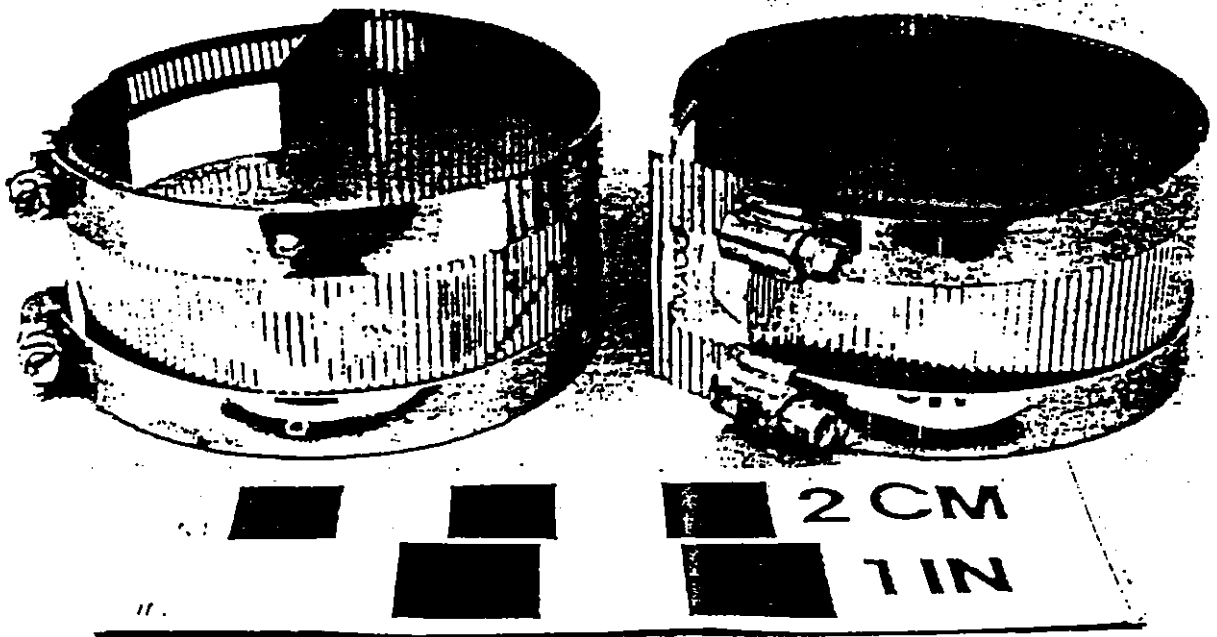

FIGURE 36b OLDER LOOKING PIPE CLAMPS FOUND IN OFFICE UNIT 1 AND CLASSROOM 2, UNIT 1 RESPECTIVELY (Note increased degree of corrosion on both these specimens).



### 5.6 Results of Electrical Analysis of the Preschool Building

Hellman of G.S.E. Communications, Inc. (a firm that specializes in alarm systems and electronic devices) came to the preschool to investigate the possibility of evidence of any electronic signaling devices that may have been present. He does report an unusual and inoperative system that was labeled "Fire Alarm"(see Appendix I.6).

### 5.7 Results of the Ground Penetrating Radar Study

A remote sensing device was used in a survey intended to help in the search for any buried tunnels or rooms both under the preschool structure itself and in the outside open yards as well. The instrument used was a Geophysical Survey Systems, Inc. unit (see Figure 37 a, b, and c). The survey instrument is contained in a low lying rectangular box mounted on wheels. The box has a handle for pulling or pushing the instrument over the ground surface of a survey site. For our survey, the instrument was run at 300 MHz, which can profile up to 10 feet (3.05 m.) below the surface and can yield good near-surface definition depending on the soil conditions. Simply put, Ground Penetrating Radar (GPR) sends down into the ground a radar signal which is reflected back to the instrument. The reflected signal can detect buried solid features such as walls or pipes and it can detect buried open (or formerly open) features such as tunnels or rooms. When a buried feature is detected, it is technically referred to as a "target" or an "anomaly". The GPR was the most suitable instrument to use at the site in question because other instruments (e.g. the terrain conductivity meter and the electrical resistivity meter) in general would be too affected by the "noise" coming from the preschool structure due to reinforcing rods and other metallic objects. Such interference produces uninterpretable records. In fact, such did occur with the District Attorney's archaeological project which unsuccessfully used the terrain conductivity meter (Langenwalter, *et al*, 1985).

The GPR survey was conducted by a commercial firm, Spectrum, of San Fernando. The firm did not provide a report to this author, despite many requests. It supplied only a cover letter and 4 graphics based on its work at the site (see Appendix I.7).

Three targets or anomalies were detected by the GPR survey. One was a large buried slab (which the operators interpreted at the time to be located at an 8-9' depth). This turned out to be the roughly poured concrete slab which was only 1 foot under the surface instead of 8-9 feet as reported by Spectrum's operators at the time (cf. Section 4.3 above).

The two other targets were more significant. Both were located directly opposite each other across the dividing wall between Classrooms #3 and #4 located toward the south end of the wall (see Section 4.1 above, Figure 20). The detection of these two targets directed our selection of the locations for openings in the concrete pad floor of both Classrooms for excavation of Unit 1, Classroom #3 and Unit 2, Classroom #4; (Figure 20). Later it was determined through excavation that the main tunnel passed directly under the same loci noted as the targets by the GPR survey.

Thus the GPR was successful in detecting the main tunnel at the locus of the dividing wall between the two classrooms.



FIGURE 1. PAGES 1-3. VIEWS OF THE DEPLOYMENT AND PAPERING OUT OF THE GROUP'S PAPER TREATMENT

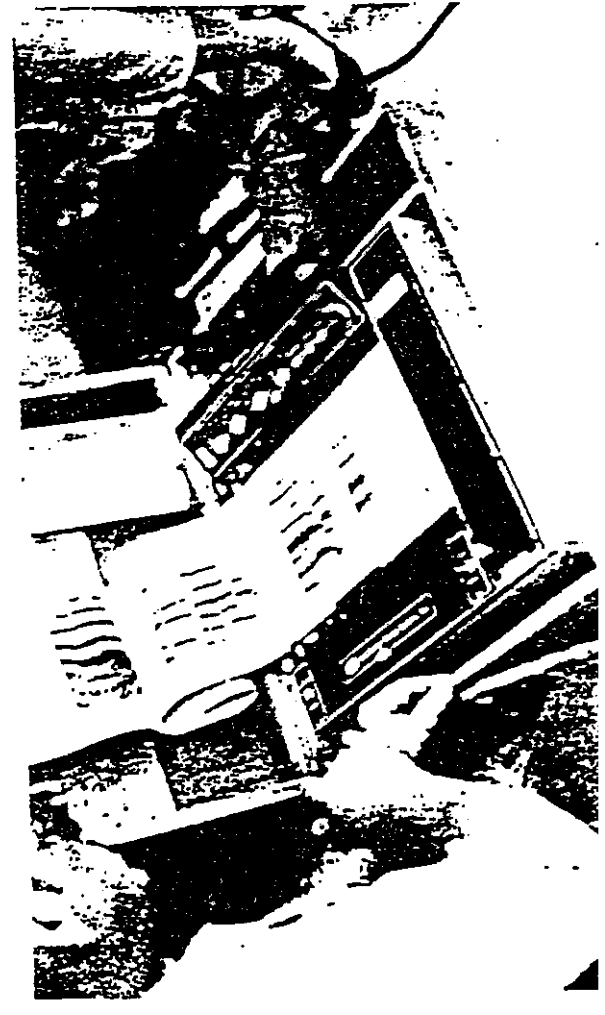
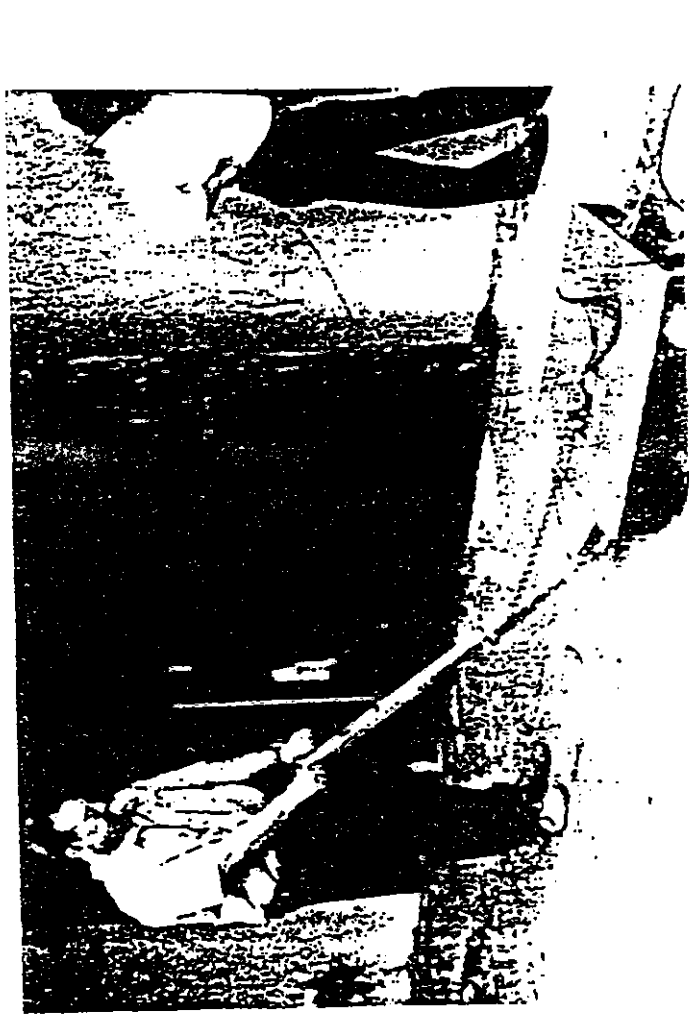

## 6.0 Synthesis of Excavated Data and Scientific Support Studies

Despite the constricted time frame for this project's field work, extensive excavations were conducted at the McMartin Preschool Site. These included 11 units (trench and pit units) which were excavated down into the soil deposits below the concrete pad floor of the structure as well as additional unit extensions that were excavated in order to follow features that continued between the initial units (such as between Classroom #1, Unit 1 and Office Unit 1 or those between Classroom #4, Unit 2 and Classroom #3, Unit 1). Also three units were excavated outside the structure in the Play Yard and Outer Yard areas respectively. In addition, some excavation and mainly profile cleaning was performed in the Outer Yard backhoe-excavated trenches (Trench Units 1, 2 and 3). Parts of the irregular "Unit 4", located in the Outer Yard adjacent to Classroom #4 were also excavated. Unit 4 had been dug with a backhoe by the parents in 1985, had four units dug into it by the District Attorney's Office archaeologists in 1985 (Langenwalter, *et al*, 1985) and had been dug up again by Hobbs and crew prior to our formal excavations (cf. Section 1.3 above).

A large number of artifacts were recovered during the excavations, totalling some 2806 specimens. These data were identified as follows: all but two were historic artifacts (2 were prehistoric Native American stone artifacts dating prior to 1542 A.D.). The historic artifacts were comprised of whole specimens and fragments of bottles, cans, bricks, paper and a range of other wooden, metal, glass and plastic items. These artifacts range in age from the 1920's to 1983.

Altogether, some 99 animal bones were recovered and identified as mainly coming from domestic cow, pig, and dog, rabbit, rodent, reptile, and other unidentifiable bird and mammal remains. The geology of the site was inspected and two radiocarbon dates were obtained.

In addition to the archaeological work *per se*, a number of other inspections of the preschool structure in terms of its concrete floor, architecture and electrical system were made. Also, observations were made on other factors that were deemed relevant such as tree root identifications.

The objectives for the project were met with the following evidence. Relevant to the children's reports of possible occult activity (cf. Appendix II), a plate, precisely drawn by an adult with three pentagrams, was recovered from Unit 1 in the preschool Play Yard (see Figures 16a and 16b).

In terms of the second and major goal of the project, to ascertain the presence or absence of tunnel(s) and/or underground room(s) under the preschool based on reports made by the children (see Appendix II), the following recovered data is relevant.

The feature first encountered in Classroom #1, Unit 1 (toilet and adjacent floor area) was followed into the Office (Unit 1) and from there to the Office toilet room Unit 1 until it was observed to exit beneath the east wall of the preschool. This feature was followed

for some 5.5 m. (18.1'). The feature was a possible tunnel in that it conformed to some of the test expectations (set forth in Section 1.4) but not all of them. The entrance could have been through the floor of the toilet room in Classroom #1, but that was not confirmed. The exit of the feature, that is, where it exited under the foundation of the west wall (see Figure 15), was a clear signature. The feature appeared to be curvilinear. It was filled up with artificial fill that did not contain much in the way of artifacts or other materials. A clear compact floor was not ascertained nor were there any indications recovered of the possible date of the feature. The possible connection of the feature with the triplex next door is discussed in Appendix V.

The feature that conforms scientifically to those attributes that identify it as a tunnel was the one uncovered under the northern E/W axis of the preschool (i.e. it extended across Classroom #4 and across most of Classroom #3). This tunnel feature was clearly distinguished from the other subsurface features that we encountered during our excavations at the site. Those non-tunnel features we identified as: 1) backhoe trenches dug by the parents in 1985; 2) archaeological units dug at the direction of the District Attorney's Office in 1985; 3) a trash pit uncovered in Classroom #2; 4) trenches for utility pipes for the preschool (e.g. the outline of the trench for the pipe crossing Unit 1 in Classroom #3); and the septic tank which had served the old house on the side lot (see Figure 9).

The northern tunnel feature conformed to virtually all of the test expectations utilized herein (see Section 1.4 for the tunnel identification requirements. These were as follows:

1) There was an identified entrance, large enough for adult human passage, leading from the surface down underground (see Figures 18a and 18b). It is notable that the entrance was located in the exact area that was concentrated upon by the District Attorney's archaeological excavation in 1985 due "to the reports of the children" of a tunnel entrance and/or buried "room" (Langenwalter *et al.*, 1985; Langenwalter, 1992b). That excavation failed to locate the entrance and probably destroyed its outermost signature. This same area, through our own research, was also identified by some of the children as one entrance to the tunnel(s) (see Appendix II).

2) The feature's architecture was both linear and slightly curvilinear (see Figure 20b) and extended for some 15.25 m. (50') including both its N/S (6.75 m.) and E/W (8.5 m.) sections.

3) The feature's architecture was large enough for adult human passage, although given the ceiling height an adult would have to walk bent over along much of the route.

4) Characteristic scars indicating that it had been dug by hand were noted in the large (room-like) sector of the feature in Classroom #4.

5) The feature had a compacted dirt floor (especially noticeable in the room-like sector) which was distinguishable from the noncompacted soil matrix found in immediately adjacent, but non tunnel, areas.

6) The tunnel was found not open.

7) In contrast, the tunnel was found to have been completely, artificially filled in with soil. The fill soil had been very tightly compacted so as to leave no small openings. The soil used for fill was distinguishable on the basis of color, texture and compaction from the original soil deposit at the site.

8) The feature's fill did contain inclusions in the form of a large number of artifacts. There were 1603 artifacts found in the tunnel, especially in the room-like sector; and including the four large containers found upright in the tunnel's passage under the dividing wall between Classrooms #3 and #4.

9) Finally, the probabilistic dating of the tunnel can be estimated.

Although the old bottles and tin cans found within the tunnel date mainly to the 1930's and 1940's, other artifacts and factors point to a much later tunnel construction date. First, given the patent date for the pipe connector straps found on the pipe crossing the tunnel in Classroom #3 (see Figure 36a, also Section 5.5 above and Appendix I.5) and the fact that the appearance of the straps is essentially new in that they exhibited no (or very little) corrosion or patina as did the other straps found under the building, it is unlikely that the straps had been placed on the pipe in 1966. In the opinion of the Historic Artifact Analyst and the archaeological team, the date of the placement of the straps is much more recent than the construction date of the preschool of 1966.

Secondly, the placement of the mailbox, that came from the Morris family's residence on the adjacent side lot (see Section 4.4 above), most probably dates to the time following the destruction of the Morris house in 1972 when the mailbox was no longer in use.

Thirdly, the Disney bag, found in the fill matrix at the entrance to the tunnel (see Section 1.3 above) has a date of 1983 which probably indicates that the tunnel fill (or at least some of it) dates to that time or thereafter.

Fourthly, the foundation, at the precise width of the passage of the tunnel under it, was slightly arched (see Figure 27). This was obviously a feature made to accommodate the tunnel and there is no other conceivable scenario to account for it if it were created before the preschool was constructed.

Fifth, the four large containers (1 ceramic and 3 metal pots) that were all found in the tunnel directly under the foundation for the dividing wall between Classrooms #3 and #4 (and which were placed by hand into that locus) all indicate the use of the tunnel after the preschool was built. This is because, given their shallow provenience under the foundation, there is no possibility that they would not have been knocked out of place and their intact glass bottle and jar contents broken when the trench was excavated in 1966 for the pouring of the concrete foundation.

Sixth, the shallow (54 cm.: 21.4") ceiling of the tunnel, especially noted under Classroom #4 in the room-like sector and between it and Unit 2 in that room, was simply too shallow to have withstood human foot traffic on it in an unprotected state. That is to say, if the tunnel feature had existed prior to the construction of the preschool, its covering or roof (made of the soft sand) would have been so shallow that a person walking on the surface would have easily caved it in, thus exposing the tunnel. The fact that the ceiling or roof of sand was still intact when we found it is most probably due to the fact that it had been protected from foot traffic or other such force by the concrete pad floor above which served as a de facto "roof."

Finally, the seventh factor is that the geologist confirms a report by the preschool's builder that the soil deposit at this part of the property (the E/W axis of the structure) had been put into place and compacted at the time of the building's construction (see Section 4.4 above and Appendix 1.3a and b). Therefore any holes or openings found in that area extending up to or near the surface would necessarily date to a time after 1966.

Therefore, given the evidence of the seven factors, the time of the construction and use of the tunnel most probably postdates 1966.

It was not resolved whether or not a buried room was encountered by our excavations. We did find that the tunnel passage from the entrance led southward to the relatively wide area filled with debris at the south end of Unit 1 in Classroom #4. This area was measured to be 2.74 m. (9') wide at points C—C' (see Figures 20b, 21a and 21b). That dimension was roughly three times the average width of the tunnel (both under Classrooms #4 and #3). As stated above, given the severe time limit, we had to abandon the full excavation of that wide area (despite the fact that it offered additional artifacts and debris) in order to devote what little time we had left (2 days) to exploring the tunnel to the fullest extent possible. If fully explored, this wide area of the tunnel may well have proven to have functioned as a room. But due to the lack of the opportunity to have obtained all the relevant data from it, the feature area's function remains indeterminate.

## 7.0 Conclusions

Prior to presenting the conclusions based on the data collected specifically for this archaeological project, a number of conclusions relative to the findings of the various investigations of the site previous to our work in 1990 can be made.

It is concluded here that, in similar investigations, reports of subterranean features (i.e. tunnels and rooms) and tangible artifacts (i.e. objects used in rituals) should be taken seriously regardless of whether they come from children or adults. Such artifacts and data are tangible in nature, and if they are present as reported, they can be discovered by scientific means. However, despite the reports of the children of such relevant physical evidence, and in the case of "tunnels" or an underground "room", potentially substantial evidence, it is remarkable that the McMartin Preschool site was not properly investigated for such evidence.

In order to successfully search for such information two measures should have been implemented: 1) the "integrity" (in archaeological terms) of the site should have been preserved by the authorities by sealing off the entire site in question at the very beginning of the investigation (i.e. in this case both the preschool site lot and the adjacent lot should have been cordoned off) to any unauthorized access until the presence or absence of the reported evidence had been adequately resolved. 2) Proper professional expertise should have been brought in to insure an objective, thorough, and capable search for the data. The purpose, of course, to immediately seal off the site would be to maximize the chance of "freezing" *in situ* (in their original locations) any potentially relevant data or evidence bearing on a case so that it could be located when it was searched for. This never did officially occur with the McMartin Case. That is, the case officially began in September 1983 and the entire site (both lots) were never sealed off by the authorities. The entire site was sealed off for the first time after some seven years, in May, 1990, when the coordinators initiated this project.

Instead of properly sealing off the entire site, the authorities *de facto* allowed a series of invasions (see Section 1.2). Indeed the first "excavation" was conducted by the defense in February, 1984 by one of their private investigators who found relevant data in the form of tortoise bones with trauma (Daily Breeze, 1987). He found those data in the side lot. It is not surprising that the defense could easily dismiss their own collected data. Then the parents, out of utter frustration with the lack of response from the District Attorney's Office, did their own digging with a backhoe about a year later (Daily Breeze, March 16, 1985b). Despite the fact that this was another haphazard and unprofessional dig, the parents remarkably managed to find more relevant evidence (additional tortoise bones) which discovery finally forced the D.A.'s Office into action. Thus two years after the investigation began, the District Attorney's Office hired a local archaeological firm to conduct a dig (on what basis they were hired is not clear). According to one of the two archaeologists in charge, the D.A.'s Office wanted the archaeological project to focus on the adjacent or side lot rather than on the preschool lot itself (where the children reported the presence of tunnels and rooms; cf. Appendix II).

It must be concluded that the D.A. project was inappropriate and inadequate based on several factors. First the goals of their project were limited only to 1) searching for "...buried remains of animals exhibiting the effects of traumatic death; and (2) ...a subterranean room" (Langenwalter, *et al*, 1985: 1). Thus a wider range of data possibly relating to ritual behavior and even the search for long buried features (i.e. a tunnel) were not explicitly considered as the formal goals of the project. Next, the type of remote sensing equipment used for that search was inappropriate, as the terrain conductivity meter is not usable in such a building or structure (as their own results indicate, cf. Beer in Langenwalter, *et al*, 1985, Appendix A). It should also be noted here that most of the children's reports about "tunnels" or buried "rooms" have repeatedly emphasized that they were located under the preschool not in the adjacent side lot (cf. Appendix II). Despite this fact, the archaeologists were "limited" to digging in the side lot (Langenwalter, 1992b: personal communication).

Apparently the archaeologists were even further limited as to where they could dig in the side lot. Despite the fact that their remote sensing equipment detected two "targets" buried in the side lot which the archaeologists deemed worthy of digging up so they could be identified, the D.A.'s office strangely did not permit them to do so (see Beer in Langenwalter, *et al.* 1985, Appendix A, p.3; 1992b; Langenwalter, 1992 personal communication). In addition, the test expectations used for the search for the subterranean features (tunnels and rooms) were inappropriate. That is, the archaeologists excavated down until they encountered either "(1) a level predating the period of interest for this case (i.e. 1966-1984) which exhibited no evidence of burial pits or similar phenomena; and/or matrix disturbed by the recent unauthorized excavations..."(Langenwalter, *et al.* 1985: 15). These are inappropriate and inadequate test expectations for locating a buried room or tunnel (cf. Section 1.4 above). Levels "predating the period of interest" may well have been encountered as the "roof" of a tunnel or room underneath (and that is what we in fact encountered in our excavations). The second factor was also inappropriate. Our project had to sort through both their excavations and others in order, for example, to ascertain the entrance to the tunnel, the outermost parts of which had been disturbed by prior work. Lastly the D.A.'s Office restricted their work to only two weeks which is not adequate to explore such a large composite site.

Thus it is concluded that the District Attorney's Office archaeological project was inappropriately restricted in where excavation could take place, the remote sensing equipment was inappropriately used since it was not applied in the most logical and relevant locus for the reported subterranean features (i.e. under the preschool), and that the two "anomalies" detected by the remote sensing equipment in the side lot were not explored and identified despite the archaeologists' recommendations. In general, the archaeological research design was inappropriate for the relevant search for tunnels or buried rooms. And the time period authorized for the dig was too short to provide for a thorough and adequate project even for the side lot.

It is apparent that legal authorities and the police are not qualified, experienced, or competent (as appropriate archaeologists are), for excavating and identifying what may be subtle underground features. Moreover, proper research designs for such projects must be formulated which include the use of test expectations relevant to the search for desired data as well as specifying appropriate equipment (e.g. proper remote sensing instrumentation). The fact that the present project utilized such critical factors, accounts for the successful outcome of our research.

Assessment of the data specific to the present project has led to the following conclusions. The children's reports that formed the objectives of this specific project, which were made at various times prior to our May, 1990 excavation, have been corroborated by our discovery of physical data in the following forms:

Reports of what have been interpreted by adults as bizarre ritual behavior which utilized occult-related symbols (cf. Appendix II) are corroborated by our discovery of a plate that had been precisely decorated by an adult with three pentagrams. This find is not a substantial indicator of occult-related behavior, but since this object was probably an *in situ* find, if it were not related to occult activity then its logical presence at a preschool would

have to be credibly explained especially given the fact that some children specifically reported seeing pentagrams at the preschool (cf. Appendix II).

Much more substantial is the evidence we recovered bearing on the questions of whether there were subterranean tunnels and rooms at the site. Due to the test expectations of soil discoloration, texture, and compactness, the project located a possible tunnel under the front part of the preschool (i.e. in the Classroom #1 toilet, leading through the Office and out under the Office Toilet Room foundation to the property next door.

The most substantial evidence for a tunnel was discovered under the north (E/W) axis of the preschool. The apparent entrance was located under the west wall of Classroom #4. Although the area had been disturbed by various diggers prior to our formal excavation, the signature of the entrance was clear and it was clear that it had been filled back in with soil and debris (cf. the observations of the consulting project Geologist, Dr. Don Michael, Appendix I.3b).

Beyond the entrance, this northern tunnel meandered under Classroom #4 and then under most of Classroom #3 to a point where it could no longer be followed. This tunnel was indicated by many factors including distinctive soil color, soil texture, soil compaction, the human sized architecture permitting passage, presence of an earthen roof (possibly with inside roofing), possible shoring, and the presence of a great number (1603) of artifacts found densely intermixed in the artificial fill within most of the tunnel.

There is no other scenario that fits all of the facts except that the feature was indeed a tunnel. The date of the construction and use of the tunnel was not absolutely established, but an assessment of seven factors of data all indicate that it was probably constructed, used and completely filled back in sometime after 1966 (the construction date of the preschool). This age assessment has also been corroborated by the consulting Geologist for the project Dr. Don Michael (1992b; cf. Appendix I.3b).

A relatively wide (2.74 m.; 9') area in the tunnel may have been a room but such an interpretation cannot be asserted with the evidence at hand.

Therefore, this project's goals or objectives were met with data which probabilistically corroborates reports made by the children regarding the site.

## 8.0 Recommendations

Based on the total assessment of this project, the following recommendations can be made. Authorities should not discount apparently bizarre and unlikely claims. Reports of subterranean features (tunnels and/or rooms), whether from adults or children, should be taken seriously and searched for in a scientific manner. In order to maximize the success of such a search, several measures can be taken. For any case in the future in which underground features of tunnels and/or rooms are suspected, it is recommended that the



local authorities immediately seal off the total site or site areas in question. Hopefully this will maximize the chance of finding any relevant subsurface data *in situ* (in its original location). Then the police or investigating authorities must obtain the services of professional archaeologists. Police and their forensic investigators lack the needed expertise and experience critical to a successful search for such features. Moreover, the supervising archaeologist should possess a Ph.D. and have the necessary field experience. Such senior standing both in terms of credentials and experience will ensure the most scientific, and useful and authoritative results.

Any such archaeological project must have a suitable research design that includes both relevant formulated testable hypotheses (relevant to the discovery of the sought after data) and the use of relevant equipment (e.g. in this case the use of Ground Penetrating Radar). If such buried tunnels are suspected in a future case, and if they are suspected as running out from underneath a structure of some kind into open surrounding areas, then it is recommended here that trenches could be dug around the bordering foundations of a structure which would permit the search for tunnel signatures in the "side walls" of such trenches. The use of remote sensing equipment could augment the resultant search underneath such structures.

## 9.0 REFERENCES CITED

Binford, L.R.

1964 A Consideration of Archaeological Research Design. *American Antiquity*, Vol. 29: 425-441.

Bottoms, Bette L., Phillip Shaver and Gail Goodman

1991 Profile of Ritualistic and Religion-Related Abuse Allegations Reported to Clinical Psychologists in the United States. State University of New York, Buffalo.

Braun, Bennett G.

1986 Treatment of Multiple Personality Disorder. American Psychiatric Press, Washington, D.C.

Blueprint

1966 "Virginia McMartin Preschool," architectural plans submitted to the City of Manhattan Beach Planning Department. The plans were approved on April 15. Plans on file at the Manhattan Beach Planning Department.

Committee on Child Abuse Prevention

1991 Ritualistic Child Abuse in California. California State Social Services Advisory Board, Department of Social Services, Sacramento.

Currie, Robert

1992 Personal Communication.

#### Daily Breeze

- 1984a Arsonist sets preschool blaze, leaves a warning. Newspaper article by Norma Meyer. April 9. Daily Breeze. Torrance, California.
- 1984b Manhattan Beach preschool searched again for evidence. Article by Norma Meyer. April 11.
- 1984c Suspect arrested in preschool fire. Article by Bob Jones, May 24.
- 1985a Boy, 10, names church, store as molestation sites. Article by Faye Fiore, February 2.
- 1985b McMMartin parents dig up yard in search of clues. Article by staff writers, March 17.
- 1985c Investigators take over excavation at McMMartin site. Article by David Hall, March 18.
- 1985d Defense lawyers want access to McMMartin findings. Article by David Hall, March 19.
- 1985e McMMartin dig site under constant guard. Article by Gregg Zoraya, March 23.
- 1985f McMMartin school excavation delayed until next week. Article by staff writers, March 28.
- 1986a Will McMMartin also fail test of state probes? Article by Faye Fiore, October 5.
- 1986b Lawyers to testify in McMMartin case. Article by Faye Fiore, December 16.
- 1987 Ex-officer apparently kills self. Article by David Hall, December 11.
- 1989 After 6 years, \$15 million, jurors get case today. Article by Norma Meyer, November 2.

#### Daily News

- 1985 Animal remains unearthed near McMMartin preschool. Newspaper article by Tony Knight, March 18. Daily News, Woodland Hills, California.

#### Easy Reader

- 1987 Former Hermosa Beach officer's suicide adds questions to McMMartin mystery. Newspaper article by Kevin Cody, December 17. Easy Reader, Hermosa Beach, California.
- 1988 Boy testifies to complex abusive acts at McMMartin. Article by Kevin Cody, April 21.

- 1990 McMartin Pre-school mystery buried beneath bulldozers, media reports. Article by Kevin Cody, May 31.
- Fallor, Kathleen Coulborn  
1990 Sexual Abuse of Children in Cults: A Clinical Perspective. Roundtable. Spring.
- Finkelhor, David and Linda Meyer Williams  
1988 Nursery Crimes. Sexual Abuse in Day Care. Sage Publications. Newbury Park, California.
- Flaherty, Don  
1992 Personal Communication.
- Ganaway, George K.  
1989 Historical Versus Narrative Truth: Clarifying the Role of Exogenous Trauma in the Etiology of MPD and its Variants. Dissociation, Vol. II No. 4, December.
- Goodwin, Jean M.  
1993 Rediscovering Sadism. Rediscovering Childhood Trauma: Historical Casebook and Clinical Applications. American Psychiatric Press, Inc., Washington D.C.
- Hester, T.R., R.F. Heizer and J.A. Graham  
1975 Field Methods in Archaeology (6th edition). Mayfield Publishing Co. Palo Alto, California.
- Historical Committee  
1977 The Streets of Manhattan. Transportation at the Beach. Manhattan Beach Historical Series Publication No. 5, published by the City of Manhattan Beach Historical Committee.
- Hobbs, Gerald  
1990 Notes on excavations and exploration of the McMartin Preschool Site, Manhattan Beach, California. Notes on file with the McMartin Tunnel Project and with the author.
- Hole, Frank and Robert F. Heizer  
1973 An Introduction to Prehistory (3rd revised edition), Holt, Rinehart and Winston, New York.
- Jones, David P.H.  
1991 Ritualism and Child Sexual Abuse. Child Abuse and Neglect, Volume 13, pp. 163-170.
- Jonker, F. and Jonker-Baker, P.  
1991 Experiences With Ritualist Child Sexual Abuse: A Case Study From The Netherlands. Child Abuse and Neglect, Volume 15, pp. 191-196.

Joukowsky, Martha  
1980 A Complete Manual of Field Archaeology. Prentice-Hall, Inc., New Jersey.

KCAL TV

1990 News segment on the McMartin Preschool dig, KCAL. Channel 9, Newscast, May 9, Los Angeles.

Kelley, Susan J.

1988 Ritualistic Abuse of Children: Dynamics and Impact. *Cultic Studies Journal. A Journal on Cults and Manipulative Techniques of Social Influence.* Vol. 5. No. 2. pp. 228-236. American Family Foundation, Weston, Massachusetts.

1989 Stress Responses of Children to Sexual Abuse and Ritualistic Abuse in Day-Care Centers. *Journal of Interpersonal Violence*, Volume 4, No. 4, pp. 502-513.

1990 Parental Stress Response to Sexual Abuse and Ritualistic Abuse of Children in Day-Care Centers. *Nursing Research*, Volume 39, No. 1, pp. 25-29, Jan./Feb.

Koch, Rudolf

1930 *The Book of Signs.* Dover Publications, Inc. London.

Langenwalter, Paul E.

1992a Personal communication (phone conversation, June).

1992b Written notes and corrections to this draft report, mailed to author on June, 30, 1992.

1993 Personal communication (conference with Tunnel Project staff, July 13).

Langenwalter, Paul E., Kevin Peter, Jane King, and Robert Beer

1985 Report on a forensic archaeological investigation conducted at the Goldstein property, Manhattan Beach, California. Report prepared for the Los Angeles County District Attorney's Office. Unpublished report on file at the contracted firm of Scientific Resource Surveys, Inc., Huntington Beach, California and at the D.A.'s office.

Lehner, Ernst

1950 *Symbols, Signs, and Signets.* World Publishing Co., Cleveland, Ohio.

Lloyd, David W.

1990 *Ritual Child Abuse: Understanding the Controversies.* The National Resource Center on Child Sexual Abuse. Wheaton, Maryland.

MacNeil/Lehrer Newshour

1990 "McMartin: Trial and Errors" (an Emmy Award winning 25 minute special segment on the McMartin Preschool Case, produced and aired on the MacNeil/Lehrer Newshour), Public Broadcasting System (PBS) television network. segment first aired June, 1990). Videotape on file at Channel KCET, Los Angeles.

McGauley, Jackie

1992 Personal Communication, May.

Michael, Don

1992a Personal Communication (letter to E.G. Stickel, June 15; see Appendix I.3a).

1992b Personal Communication (letter to E.G. Stickel, July 2,; see Appendix I.3b).

Morse, Dan, Jack Duncan and James Stoutamire

1983 Handbook of Forensic Archaeology and Anthropology, Florida State University Foundation, Inc. Tallahassee, Florida.

Munsell

1975 Munsell Soil Color Charts (1975 Edition). Macbeth Division of Kollmorgen Corporation, Baltimore, Maryland.

Nathan, Debbie

1990 What McMartin Started: The Ritual Sex Abuse Hoax. Newspaper article in the Village Voice, New York City, Vol. XXXV, No. 24, June 12. Note: review cited in introduction was published in NASW (National Association of State VOCAL Organizations) News/CAVOCAL (California Victims of Child Abuse Legislation), newsletter, Vol. 7, no. 3, Fall, 1991, p. 3. VOCAL Public Relations, P.O.Box 462, Deer Park, California 94576

Noel-Hume, Ivor

1975 Historical Archaeology, Norton, New York.

Office of Criminal Justice Planning

1989/

1990 Occult Crime: A Law Enforcement Primer. Research Update, Special Edition, Volume 1, No. 6, Winter. State Office of Criminal Justice Planning, Sacramento, California.

Ofshe, Richard

1993 Making Monsters. Society, Vol. 30, No. 3.

Permit

1962 Application to "Excavate approximately 80 cubic yards of earth," Excavation Permit (presumably preparatory to the preschool construction), permit granted and on file at the City of Manhattan Beach Building Department.

- Putnam, Frank W.  
1991 The Satanic Ritual Abuse Controversy. *Child Abuse and Neglect*, Vol. 15, pp. 175-179.
- Sandborn Map  
1928 Portion of map of Manhattan Beach, Sandborn Map Company, Los Angeles.
- Schiffer, Michael  
1976 *Behavioral Archaeology*. Academic Press, New York.
- Smith, Martin R.  
1992 A Reply to Ganaway: The Problem of Using Screen Memories as an Explanatory Device in Accounts of Ritual Abuse. *Dissociation*, Vol. V, No. 2. June.
- Snow, Barbara and Teena Sorenson  
1990 Ritualistic Child Abuse in a Neighborhood Setting. *Journal of Interpersonal Violence*, Volume 5, No.4. pp. 474-487. December.
- South, Stanley  
1977 *Method and Theory in Historical Archeology*. Academic Press, New York.
- Stickel, E. Gary  
1979 More on Theory Building in Archaeology. *Current Anthropology*, Vol. 10; pp. 621-622.
- 1982 A General Human Systems Model for Archaeological Analysis. *In New Uses of Systems Theory in Archaeology*, ed. by E.G. Stickel, pp. 10-72, Ballena Press, Los Altos, California.
- 1983 The Mystery of the Chinese Anchors: Towards Research Designs for Aquatic Archaeology. *In Shipwrecks as Anthropology*, ed. by Richard Gould, School of American Research Advanced Seminar Series, University of New Mexico Press, pp. 219-244.
- Stickel, E. Gary and Joseph C. Chartkoff  
1973 On The Nature of Scientific Laws and Law-building in Archaeology. *In The Explanation of Culture Change: Models in Prehistory*, ed. by Colin Renfrew, Duckworth Ltd., London. pp. 663-672.
- Stickel, E. Gary and Ervan Garrison  
1988 New Applications of Remote Sensing: Geophysical Prospection for Underwater Archaeological Sites in Switzerland. *In Wet Site Archaeology*, ed. by Barbara Purdy, University of Florida/The Telford Press, Caldwell, N.J., pp. 69-88.

Summit, Roland C.

1988 Hidden Victims, Hidden Pain; Societal Avoidance of Child Sexual Abuse. *In* Lasting Effects of Child Sexual Abuse, ed. by Gail Wyatt and Gloria Powell Sage Publications, Newbury Park, California. pp. 39-60.

1989 The Centrality of Victimization; Regaining the Focal Point of Recovery for Survivors of Child Sexual Abuse. *Psychiatric Clinics of North America*. Vol. 12, No. 2, pp. 413-430.

The Beach Reporter

1985 Parents take initiative in McMartin site search. Newspaper article by Mary Kinetz, March 21. The Beach Reporter, Manhattan Beach, California.

U.S.A. Today

1985 Massive case bogs down at hearing. Newspaper article by Eric Brazil, March 21. U.S.A. Today, Washington, D.C.

Waterman, Jill, Robert J. Kelly, Mary Kay Oliveri and Jane McCord

1993 Behind the Playground Walls: Sexual Abuse in Preschools. Guilford Press, New York.

Watson, P.J., S.A. LeBlanc and C.L. Redman

1984 Archaeological Explanation. Columbia University Press.

Wedek, Harry

1961 Treasury of Witchcraft. Philosophical Library, New York.

Wiley, E.L.

1991 The McMartin Preschool Case. *State Police Officers Journal*, Vol. 40, No. 3, pp. 66-90.

Wilson, Charles and Susan Caylor Steppe

1985 Issues in the Investigation of Child Sexual Abuse in Day Care Centers. State Department of Human Services, Nashville, Tennessee.

Worth, Valerie

1971 The Crone's Book of Words. Llejelly Publications, Saint Paul, Minnesota.

Young, Walter C., Roberta G. Sachs, Bennett G. Braun and Ruth T. Watkins

1991 Patients Reporting Ritual Abuse in Childhood: A Clinical Syndrome. Report of 37 cases. *Child Abuse and Neglect*. Vol. 15, pp. 181-189.

## 10.0 Acknowledgements

Without the sensitivity, patience, and cooperation of Mr. Arnold Goldstein the owner of both the vacant lot and the preschool properties in 1990, the successful results of this project would never have come to light. On behalf of the parents and especially the children, we will be forever grateful to Mr. Goldstein for his great kindness and extreme generosity.

Hobbs was invaluable to the project in countless ways. From his experience in underground excavations and his expertise as a tree surgeon, to his great abilities as a mediator when feelings got bruised and his sensitive way with the children, Jerry was everyone's friend and confidant. When we extended the final date of the project three times, Jerry delayed opening his new store, "Azusa Gold," to stay with us until the last day.

Flaherty, Crew Chief, was a tremendous asset to the project for his willingness to work long hours despite a severe bout with bronchitis. The dedication, intelligence, sensitivity and kind manner Don brought to the project cannot be measured. In addition, Don generously donated the wages owed to him at the end of the project to the cause.

The professional archaeological crew went beyond expectations with their untiring, dedicated efforts to complete the project under unusually stressful and demanding conditions. Thanks to Sandy Collier, Robin Cummins, Michael Fene', B.J. Schenk, and Monica and Milosh Gulai.

We were very fortunate to have available to us some of the finest professionals in their fields as our consulting scientists. Special thanks to Dr. Herbert Adams, Dr. Rainer Berger, Hellman, Dr. Don Michael, Minard, and Dr. Charles Schwartz.

The backbone of the project was the persevering volunteer crew. Especially Judy Winkler, Chris Clark, Libbe HaLevy, Mary Hitt, Johanna Michaelsen, Randolph Michaelsen, Randy Michaelsen, Sandy Munro, Meisha Silva, Paul Krikrak, Patrick O'Shea, Stan Ibraro, Samantha Khury-Ibraro, and numerous parents of children who had attended the preschool. They shoveled dirt, provided lunch, hot tea on cold nights, lent us equipment, latrines, donated services and funding. Thanks to the neighbors who lent us bathrooms, telephones, electricity, water and moral support.

The project would like to acknowledge the following organizations that contributed to its sustenance with their in kind contributions: Families of Crimes of Silence (F.O.C.O.S), Tom Reddin Security, Miko Photography, Superior Concrete, and California Labs of Tustin, California.

In the last days of preparing this report we faced unexpected financial problems. M.A.S.A. (Mothers Against Sexual Abusers) graciously arranged for donations to be made through them, and matched a generous donation from Gloria Steinem thus allowing the report to proceed on schedule.

And finally, we would like to show our appreciation to the members of the media who portrayed the project in a fair and unbiased light. We gratefully acknowledge Chris Harris of KTTV, Heidi Vanderbilt of *Lear's Magazine*, E.L. Wiley of *State Police Officers Journal*, and Rachel L. Heller of *The Beach Reporter*.



## 11.0 GLOSSARY

**Anomaly:** (e.g. a Ground Penetrating Radar anomaly). In remote sensing surveys (or searches of the landscape which utilize high technology equipment such as radar, sonar, magnetometer, electrical resistivity instruments, etc.), an "anomaly" or "target" are terms used to describe detected features which are sought (i.e. the object of the survey) and/or which need to be identified by further research.

**Archaeology:** The science which excavates artifacts and other data in order to reconstruct and explain past cultures and human behavior.

**Artifact:** An object manufactured and utilized by human beings for some task(s).

**Archaeological Site:** A locus which contains two or more artifacts or ecofacts which were involved in past human behavior that was conducted at that place.

**Bioturbation:** The disturbance of an archaeological site by rodents or other fauna who dig burrows or the like.

**Ecofact:** A piece of nature that is brought to or is found at an archaeological site due to past human activity. Examples are unmodified stones (e.g. a quartz crystal) or bones from a deer. Locally, animal bones and pieces of shellfish are commonly found ecofacts at archaeological sites.

**Feature (archaeological):** A complex comprised of two or more artifacts and/or ecofacts that were functionally associated (e.g. fire-burnt stones and charcoal comprising an ancient fireplace).

**Forensic:** Having to do with evidence suitable for legal, particularly criminal court cases.  
**Ground Penetrating Radar (G.P.R.):** A type of radar used to search for items or features underground.

**Historic Archaeology:** A subfield of Archaeology which excavates and/or studies archaeological data and historic records in order to more fully reconstruct and explain past human behavior and cultural sites. Historic, or Historical, Archaeology, exclusively deals with sites and data coming from cultures which had a written language (which makes the site or artifact "historic"). Locally Historic Archaeology begins in 1542 A.D. with the arrival of Cabrillo.

***in situ*:** The original location of an artifact as it was discarded or abandoned by a person in the past.

**Munsell Soil Color:** A formal set of colors used to measure various hues of soils. These colors are provided in a reference book that can be used in the field for accurate measurement (Munsell, 1975).

**Overburden:** The nonessential, nonrelevant, usually natural soil layer that overlies an archaeological deposit of interest.

**Patina:** a surface modification of metal (e.g. copper, bronze, iron, steel) or glass formed by chemical modification of an item's surface. Made be caused by chemical/physical buried ground conditions or by acids.

**Provenience:** A special American Archaeological term that refers to the exact spatial location (both horizontal and vertical) of a site, feature or artifact determined on the basis of measurements (usually in the metric system) from a stipulated reference point(s). Provenience facilitates the reconstruction of the location of data in the laboratory for analysis. Old World Archaeologists use the term "provenance" for the same concept.

**Provenience control:** The system used for recording the provenience of archaeological data (e.g. the use of a grid system for the placement of excavation pits).

**Remote Sensing:** A type of high technological search of the landscape using special techniques and equipment such as satellite photography, sonar and magnetometer searches.

**Signature (Archaeological):** A distinctive pattern, usually visually observable, in an excavated soil area (either a vertical or horizontal soil profile in a pit or trench), that is the remains of a feature. Examples include house pits, fire pits, storage pits, post holes and tunnels.

## APPENDIX I: Scientific Support Studies

### APPENDIX I.1: Introduction

The following six reports discuss the specific findings by scientists, various professionals, and a geophysical firm. These studies were all commissioned for the project.

The analyses included: radiocarbon dating, Dr. Rainer Berger; geology, Dr. Don Michael; faunal analysis, Dr. Charles Schwartz); historical artifact analysis, Mr. Jeff Minard; electrical analysis, Mr. Jeff Hellman; and the Ground Penetrating Radar Study.

Modern archaeological research requires an array of data from different sources that is best supplied by specialized scientists. The following information is integrated into the preceding main text and evaluated as to its relevance.

**APPENDIX I.2 Radiocarbon Analysis**

by Dr. Rainer Berger



INSTITUTE OF GEOPHYSICS AND PLANETARY PHYSICS  
LOS ANGELES, CALIFORNIA 90024  
Tel: 213-825-1469

October 26, 1990

The burnt wood samples you submitted for radiocarbon dating have been tested with the following results:

No. 223 found 5/2/90 Radiocarbon Content -2.3 % (UCLA-2841)

No. 227 found 5/2/90 " " -5.3 % (UCLA-2842)

The radiocarbon concentration stated in percent provides a better age estimate than giving years when modern samples are involved.

A brief interpretation clearly indicates that the wood samples, in terms of when the original trees were felled, did not grow more recently than the late 1950's as no bomb radiocarbon is present. The dates are commensurate with growth in the 1930's or so, although UCLA -2842 at -5.3 % could also be thought of as stemming from a roughly 400 year old tree. Please feel free to discuss these dates with me in greater detail. UCLA will bill you separately for \$ 500.-

Sincerely yours,

*C.R. Berger*  
C.R. Berger  
Professor

**APPENDIX I.3a: Geological Study**

by Dr. Don Michael

E. D. MICHAEL, CONSULTING GEOLOGIST  
ENGINEERING GEOLOGY • HYDROGEOLOGY • FORENSICS  
6225 BONSALL DRIVE • MALIBU • CALIFORNIA 90265 • 310 • 457-9319

June 15, 1992

E. Gary Stickel, Ph.D.  
Environmental Research Archaeologists  
Los Angeles Bicentennial Station  
P.O. Box 480074  
Los Angeles, California 90048

Dear Dr. Stickel;

The following information is offered in response to your letter of June 9, 1992. In forwarding it however, I want to make clear the extent of my involvement in exploration of the McMartin Pre-school site. Prior to my visiting the site, I was contacted by Mr. Ted Gunderson who asked me if I would help in identifying any tunnels that might exist under the school building in the event they had been filled. Since this would involve essentially distinguishing between artificial fill and earth materials in situ, work with which I am familiar, I agreed. My efforts at the site over a period of about a month consisted essentially in examining various trenches in both the southern and northern wings of the building and in the vacant lot adjacent on the west most of which were excavated under your direction..

I observed in various trenches dug through the slab of the northern wing clear evidence of an older filling episode over a slope that originally extended downward to the north on the northern side of Manhattan Beach Boulevard, and a local younger episode of filling that was apparently undertaken for the construction of the school building. The older fill was simply dumped sand which included some junk and organic debris whereas the younger fill had evidently been placed under controlled conditions, i.e., compacted to a predetermined density as is required by the local building code. The only anomalous feature I observed was especially deep stem wall in the center of the northern wing that is not indicated in the foundation plans.

In response to your specific questions:

(1) Manhattan Beach is underlain entirely by dune sands probably deposited within the previous 10,000 years, i.e., during the Holocene Epoch of the Quaternary Period. At some locations, at the surface there are developed sections of a relatively dark more clayey material that I take to be a rudimentary "A" soil zone.

(2) I observed no bedding planes or similar features which would permit the determination of the attitudes of depositional layers, although I did get the impression in several of the trenches that the deposits had been laid more or less horizontally. It should be emphasized that attitudes in aeolian deposits have limited significance, at least locally.

(3) The dune sands I observed were very well compacted. 111A

June 15, 1992

Sticker - 1

composite of six samples had an average field density of 1.86 g/cc. and an average moisture content of 15.6 percent. The size of the sample ranged from somewhat above 0.701 mm. to less than 0.124 mm. with some colloidal material. About 30 percent of the sample was smaller than 0.124 mm., i.e., in the range of very fine-grained sand, silt, and clay. About 5 percent of the entire sample probably was of clay size.

My drawing, a copy of which you included in your letter, is not of a "tunnel entrance" insofar as I am concerned, although I can understand that a more extensive excavation might have determined it to be such. Generally, the results of my examinations were negative insofar as proving the existence of a tunnel. It was my understanding that the suspected tunnel was of such a size that would have allowed children to be led, presumably by an adult, from some location within the school structure to some location outside of the structure. To be safe, it would have required shoring, i.e., some sort of support for the walls and ceiling, because the dune sand, even as well compacted as it is, would cave if it became too damp.

Too much time has passed for me to now add comments to the drawing. The "af" designation indicates artificial fill exposed in the area of the excavation as shown when I examined it, and the dimensions are self-explanatory except that the edge of the slab to the left is at the northwestern corner of the building and the depth of the excavation beneath the slab was about 5 feet. The excavation was done by Mr. Jerry Hobbs, and I believe it was he who found the piece of plastic beneath the slab with a date that was later than the date of construction.

That is actually all I know about the site. Since I never was able to form any definite helpful conclusions and was deeply sympathetic to the parents' obvious concerns, real or imagined, I did not charge them. At this late date, I am not comfortable in getting involved again. I hope this is adequate for your purposes.

Very truly yours,



E.D. Michael



I. 3b Drawing by E.D. Michael. Referred to in text *Reference*

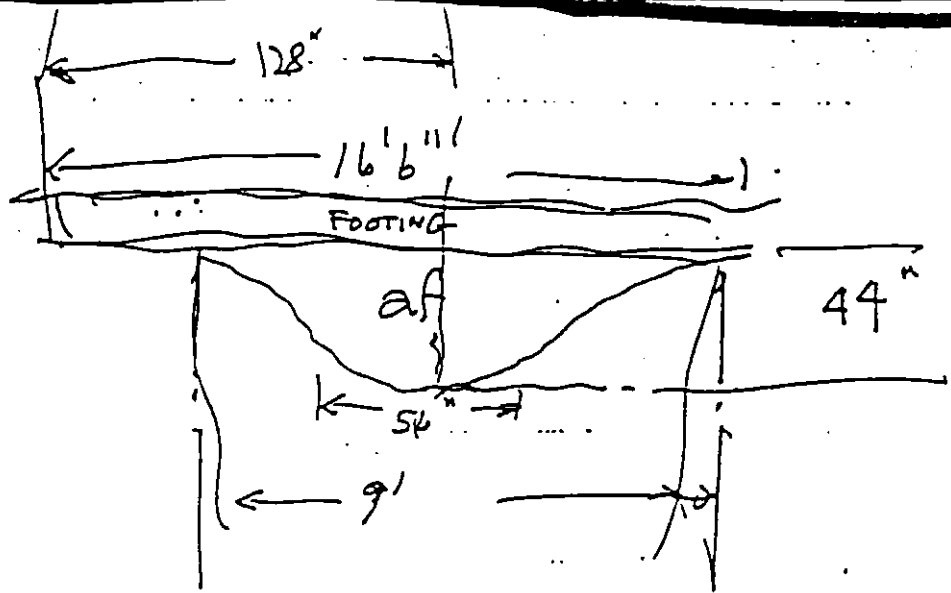

**APPENDIX I.3b: Addendum to Geological Study**

By Dr. Don Michael

E. D. MICHAEL, CONSULTING GEOLOGIST  
ENGINEERING GEOLOGY • HYDROGEOLOGY • FORENSICS  
6225 BONSALL DRIVE • MALIBU • CALIFORNIA 90265 • 310 • 457-9319

July 2, 1992

E. Gary Stickel, Ph.D.  
Environmental Research Associates  
Los Angeles Bicentennial Station  
P.O. Box 480074  
Los Angeles, California 90048

Dear Dr. Stickel:

This letter is in response to yours of June 24. It is intended to supplement and correct my letter to you of June 15. That letter was written when I was under the impression that the cavity I examined beneath the western foundation wall and slab of the northwestern wing of the McMartin School building had been excavated by Jerry Hobbs. I now understand from you that Hobbs did not excavate it but rather found it more or less as I saw it during my examination. The following are my responses to your specific numbered questions.

- (1) I made the drawing on May 8, 1990.
- (2) The drawing is a sketch of a cavity beneath the building slab looking into it from the outside. The more or less U-shaped curve is about the shape of the bottom of the cavity, seen in cross-section, directly below the exterior building wall footing.

The "af" symbol indicates that the material exposed in the cavity, i.e., in its bottom, sides, and back, is artificial fill. "Artificial fill" as the engineering geologist commonly uses the term, refers to earth materials placed for some sort of construction; however, it can refer to any soil, mineral, or rock material, indurated or unindurated, and any included materials of whatever origin, such as trash, physically emplaced by man. Artificial fill, by definition, can be regarded as a geologic formation if its boundaries can be placed upon a map. It differs from all other geologic formations in that its mode of emplacement is artificial, i.e., due to the operations of man, rather than to some natural process.

The bottom of the cavity when I examined it was 56 inches wide. Its maximum width at the top, beneath the slab, was 9 feet. The maximum depth was 44 inches. The approximate centerline of the cavity was 128 inches from the

July 2, 1992

Stickel - 2

northwestern corner of the building. The southernmost edge of the cavity beneath the slab was 16 feet 6 inches from the northwestern corner of the building.

Had I been aware that the cavity was found by Hobbs when he dug the trench along the side of the building, rather than assuming he had excavated as he did the trench, I would have taken photographs and made a more careful sketch. As it was, I simply assumed there would be additional digging, and I made the sketch primarily for the purpose of indicating its general configuration and location at the time of my examination.

It is important to understand that the cavity could have been formed in any of three ways: (a) it could have been excavated, i.e., created by the removal of material that previously occupied the volume of the cavity; (b) it could have been left as a result of the incomplete filling a previous, larger cavity such as a tunnel excavation; (c) it could have formed as the result of the caving of an underlying cavity.

(3) It is my understanding that Hobbs found in the cavity a wrapper for a Disney Corporation toy of some kind bearing a date subsequent to that of the building's construction. My notes indicate that the wrapper was a plastic bag imprinted with cartoon characters and bearing a copyright symbol and the date 1983. Therefore, the cavity could be no older than 1983, assuming the Disney Corporation did not manufacture a wrapper prior to the time of the copyright date appearing upon it. Even if it did, it probably would not have done so much before 1983 and certainly not as early as 1966 when the McMartin School building was constructed.

(4) I do not recall the comment, but I have never used the word, "unstabling." I did remark that the walls of a tunnel dug in the dune sands would be unstable, i.e., prone to caving, especially if the sands became too moist.

(5) My last examination of trenches at the McMartin School was on May 24, 1990. Those trenches were ones I understood were excavated under your direction at various locations in the northwestern wing.

I have enclosed a copy of the resistivity profile Dr. Herbert Adams of the Geology Department, California State University, Northridge, and I prepared. The profile was taken along a traverse between the school building and the house in the

July 2, 1992

Stickel - 3

property adjacent to the north. The traverse was parallel to the northern wall of the school building, about 5 feet from it, and it extended about 20 feet east of a line projected northward along the eastern school building wall (see the sketch on the reverse side).

The profile indicates an anomalous increase in resistivity at a point a few feet east of a line projected to the north along the eastern school building wall and a depth probably not greater than 10 - 15 feet. Its significance is not immediately apparent, but, presumably, a cavernous zone would have a somewhat similar signature. An attempt to penetrate to the anomaly using a hand-held engine-driven auger was unsuccessful because of caving of the loose sand. Due to the proximity of the buildings, and the necessity to extensively damage the neighboring yard if a back-hoe were brought in, no other exploration was attempted.

Very truly yours,



E.D. Michael  
RG 270; EG 157

McMartin Preschool Electrical Resistivity Profile

10:00 AM, April 28, 1990

Location: S side (rear) of bldg, 32" S. of fndn.,  
 Profile runs west to east, parallel to bldg fndn.  
 and started 22" E of SW bldg corner

} "bldg" refers to house  
 adjacent to school on the north

Run # 1

Spacing of Electrode	Center of Run	Reading (dial)	Mult.	Apparent Resist. ohm-feet	Comments
8.0	12.0	139.9	1.0	1119.2	
8.0	20.0	117.5	1.0	940.0	
8.0	28.0	119.3	1.0	954.4	
8.0	36.0	160.6	1.0	1284.8	
8.0	44.0	113.9	1.0	911.2	Ground damp from 40' on
8.0	52.0	138.0	1.0	1104.0	

Run #2

Same tape setup, electrodes mov

8.0	16.0	115.0	1.0	920.0
8.0	24.0	113.5	1.0	908.0
8.0	32.0	147.3	1.0	1178.4
8.0	40.0	133.9	1.0	1071.2
8.0	48.0	119.3	1.0	954.4
8.0	56.0	121.9	1.0	975.2

Electrical Resistivity Profile  
 McMartin - April 28, 1990

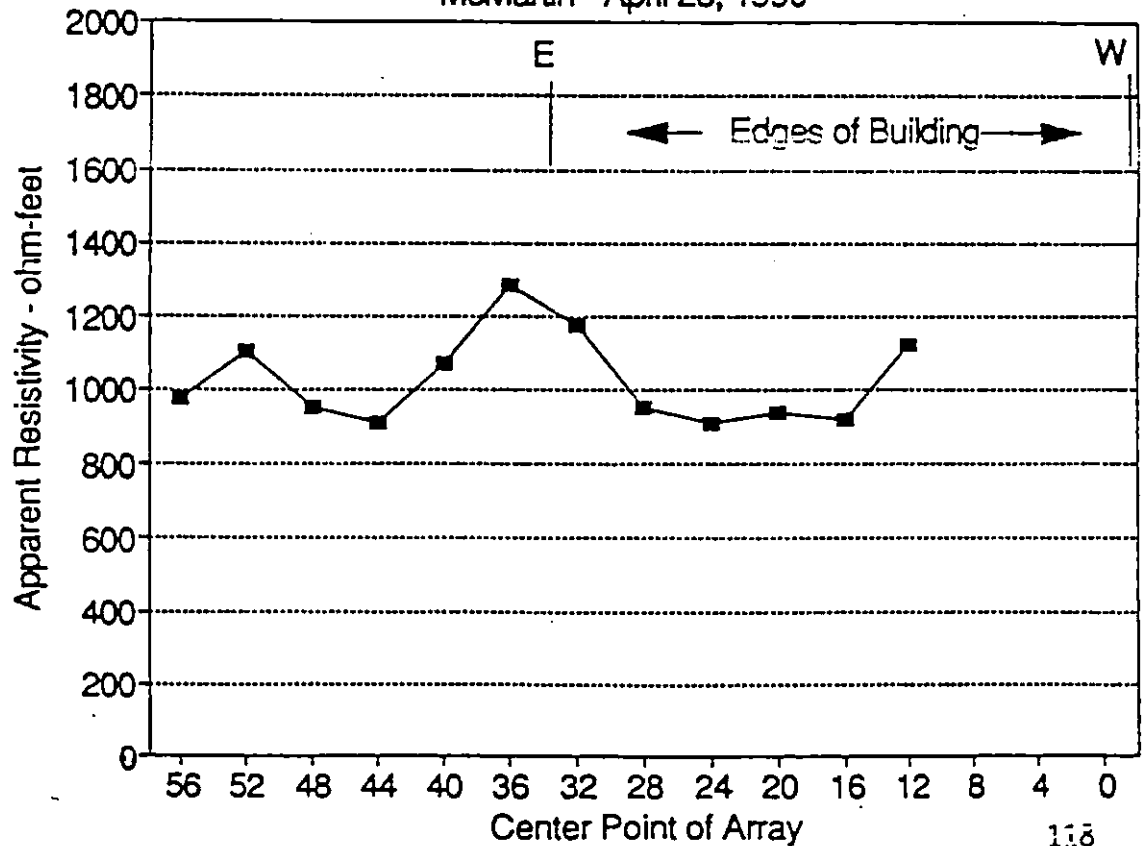

N  
no scale

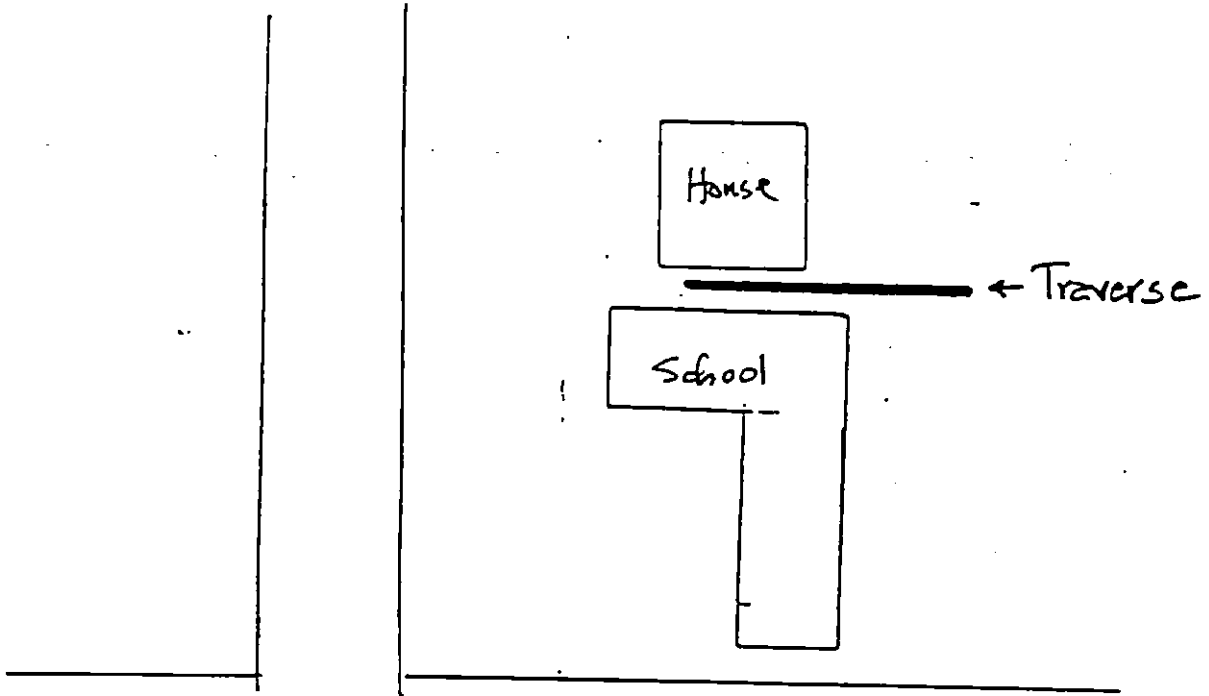

Manhattan Beach Blvd

**APPENDIX I.4: Zooarchaeological Analysis**

**a) Initial Faunal Report, June 2, 1990**

**by Dr. Charles Schwartz**



June 2, 1990

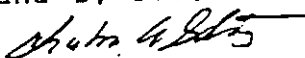

The McMartin Pre-School Osteological Remains

by

Charles A. Schwartz, Ph.D.

Bones from the McMartin Pre-School site are all from domestic mammals. Their preservation is 5 on a scale from 10-0. When brushed with a medium bristle toothbrush some of the bone tended to crumble. This may have been due to an excessively acid and/or moist soil in which they were deposited. These factors tend to mask the actual age of the bones. However, there is only a light patina on the bones with little staining present. There are no real butcher marks except those caused by a band saw.

204 Proximal left radius shaft; more proximal than no. 209. Both ends have coronal cuts with a ripple pattern perpendicular to the cut. Cuts made by band saw.

animal type: Bos taurus L., domestic cattle  
fragment size: 82 mm. length  
48 mm. width of shaft  
26 mm. breadth of shaft  
weight: 117.5 g.

207 Left femur, whole. Broken in recovery.

animal type: Gallus dom. L., chicken  
fragment size: 85 mm. length  
17 mm. proximal width of epiphysis  
16 mm. distal width of epiphysis  
10 mm. breadth of proximal epiphysis  
13 mm. breadth of distal epiphysis  
weight: 2.7 g.

207 Rib fragment. Has been cut distally-coronal plane.

animal type: cattle?  
fragment size: 74 mm. length x 17 mm. width  
weight: 8.5 g.

208 Right tarso-metatarsal shaft with proximal and distal epiphysis missing. Distal portion appears to have been lost recently possibly due to recovery techniques.

animal type: Gallus dom. L., chicken  
 fragment size: 6.5 mm. x 6.2 mm.  
 weight: 4.0 g.

- 208 Right humerus—shaft and distal epiphysis present. However, proximal epiphysis appears to have been lost in recovery from soil.

animal type: Gallus dom. L., chicken  
 fragment size: 59 mm. length  
                   48 mm. width of distal epiphysis  
                   15 mm. breadth of distal epiphysis  
 weight: 1.5 g.

- 209 Proximal left radius shaft. Both ends of shaft have been cut in the coronal plane and exhibit a ripple pattern perpendicular to the cut. Cuts made by band saw.

animal type: Bos taurus L., domestic cattle  
 fragment size: 67 mm. length  
                   48.2 mm. width of shaft  
                   29 mm. breadth of shaft  
 weight: 24.15 g.

- 210 Femur shaft fragment

animal: Gallus dom. L., chicken  
 fragment size: 54.7 mm. x 8 mm.  
 weight: 1.3 g.

- 210 Bone fragment—unidentifiable to element.

animal type: unidentifiable  
 fragment size: 13 mm. x 7.3 mm.  
 weight: 1.7 g.

- 216 A Proximal right scapula with medial portion missing. An oblique sagittal cut removed acromion and part of collum.

animal type: Bos taurus L., domestic cattle.  
 fragment size: 57 mm. width X 69.5 breadth  
                   69 mm. maximum length  
 weight: 82.1 g.

228 Rib fragment coronal section cut at both ends.

animal type: Bos taurus L., domestic cattle?  
fragment size: 88 mm. x 29.5 mm.  
weight: 32.0 g.

229 Two fragments of burned (charred) bone. Apparently one piece from a split rib.

animal type: unidentifiable  
fragment size: 38.5 mm. x 6.5 mm.  
weight: 1.2 g.

312 Burned rib fragment. Specimen had white surface with a slightly darker interior; burned.

animal type: unidentifiable  
fragment size: 14 mm. x 9 mm.  
weight: 0.6 g.

315 This fragment appears to have been associated with a fire. Although the specimen does not show direct burn marks its whitish cast and hardness are atypical for a normal bone. It is also not a weathered bone given these characteristics. A possible distal tibia, left medial side.

animal type: unidentifiable - dog size  
fragment size: 21.5 mm. x 12 mm.  
weight: 1.5 g.

330 Cervical vertebral element; left, caudal. Cut in the coronal plane and separation of the vertebra at the mid-line plane. Caudal end incompletely formed; immature.

animal type: Sus scrofa dom., domestic pig  
fragment size: 42.0 x 17.5 mm.  
weight: 1.8 g.

331A A left proximal scapula fragment with articulation from a juvenile animal. Part of the acromion is missing with root structures present on the bone. The collum has been severed with a smooth cut exhibiting perpendicular ribbing to the cut. Cut made by a band saw.

animal type: Sus scrofa dom., domestic pig  
 fragment size: 30 mm. articular width  
                   26 mm. articular breadth  
                   24.5 mm. collum width  
 weight: 8.0 g.

331B A left proximal ulna. Ventral portion is present minus articulation. It has been cut in the transverse plane and also in the frontal plane proximally. The distal end has been broken.

animal type: Sus scrofa dom., domestic pig  
 fragment size: 40.0 x 25.0 mm.  
 weight: 8.2 g.

331C sternum; juvenile

animal type: pig ?  
 fragment size: 26 mm. x 33.5 mm.  
 weight: 2.45

231D Thoracic vertebra; left caudal. It has both transverse and coronal cuts plus being broken in the transverse plane.

animal type: Bos taurus L., cattle  
 fragment size: 39 mm. length of body  
                   34 mm. width of body  
 weight: 24.0 g.

332B Left ventral ulna fragment. Specimen has two clean cuts; one medial-lateral which would have removed the olecranon process and the other is proximal-distal which removed the dorsal part of the ulna.

animal type: Sus scrofa dom., domestic swine  
 fragment size: 43 mm. length  
                   24.7 mm. width  
                   28 mm. breadth  
 weight: 6.2 g.

347 Proximal humerus. Fresh and old breaks. All major articulation points missing.

animal type: unidentifiable - medium dog size  
 fragment size:  
 weight: 0.85 g.

Salas A: First phalange with a portion of the ventral medial surface missing. Lateral portion of proximal articulation present. There are two wear surfaces (incomplete holes 1 mm. in diameter) opposite each other on the diaphysis. They are darker in color than the rest of the bone. These are a modifications by man. The distal end is partially gnawed, but is also more recently some disintegration of the bone. This more recent disintegration is also apparent in the proximal epiphysis too.

animal type: Sus scrofa dom., domestic pig  
fragment size: 57.3 mm. x 21 mm.  
weight: 0.9 g.

Salas B: Fragment of a vertebral disk.

animal type: ?  
fragment size: 24 mm. x 17.5 mm.  
weight: 0.5 g.

#### Conclusion

All the bones are from domestic animals; birds and mammals. The condition of the bones tends to mask their age. Given their condition and the patina it is estimated that they are not older than one hundred years. Other related material e.g. bottles may furnish a more exact date as to the deposition of the bones.

The animals found are domestic cattle (6 specimens), domestic pig (6 specimens), and domestic chicken (4 specimens). There are also six unidentifiable bone fragments.

Butchering patterns are limited given the samples fragmentary nature although the cattle bones exhibit clean cuts made by a band saw. Other man imposed marks are not observed nor are tooth impressions or even the breaking of the long bones for marrow.

All the cattle bones are from adults as are the chicken bones too. Pig bones represented adults, juveniles, and immature individuals.

**APPENDIX I.4b: Zooarchaeological Analysis**

**b) Second Faunal Report, June 15, 1990**

**By Dr. Charles Schwartz**

June 15, 1990

## The McMartin Pre-School Osteological Remains (2nd report)

by

Charles A. Schwartz, Ph.D.

Bones from the McMartin Pre-School site are from domestic and wild animals. From a total of 77 bones (Figure 1) over 50 percent are from domestic cattle and pig with 10 percent from wild species and 11 percent from domestic chicken. Their preservation is 5 on a scale from 10-0. When brushed with a medium bristle toothbrush, some of the bone tended to crumble. This may have been due to an excessively acid and/or moist soil in which they were deposited. Several of the bones exhibited fresh breaks which occurred in excavation. Other specimens had straight surfaces which were made by using the bone in a fashion so as to grind away the bone. In these examples these surfaces were not polished. These factors tend to mask the actual age of the bones. However, there is only a light patina on the bones with little staining present. There are no real butcher marks except those caused by a band saw. There was one intrusive rodent recovered.

---

 Distribution of Bone Elements from the McMartin Preschool
 

---

Figure 1

species	
<u>Bos taurus</u> L., domestic cattle	19
<u>Sus scrofa dom.</u> L., domestic pig	19
<u>Canis familiaris</u> L., dog	2
<u>Gallus dom.</u> L., chicken	9
<u>Sylvilagus</u> sp.? rabbit	1

rodent	1
reptile	1
Aves-bird	5
large mammal	1
unidentifiable	<u>19</u>
total	77

Room 4, U2F1: Femur shaft fragment; cut with saw bisecting shaft.

animal type: cattle?  
 fragment size: 36.2 mm. length  
 17.0 mm. width

Rome 4, unit 1: Proximal right epiphysis, tibia, sub-adult

animal type: Sus scrofa dom. L., domestic swine  
 fragment size: 62.0 mm. width  
 42.0 mm. depth

Room 4, unit 1, sec. 1: Femur shaft fragment, right. Shaft cut on a diagonal across shaft by saw.

animal type: Sus scrofa dom. L., domestic pig  
 fragment size: 90 mm. length  
 26 mm. width  
 25 mm. depth

Humerus shaft bisected by two saw cuts on proximal and distal end.

animal type: Sus scrofa dom. L., domestic pig  
 fragment size: 19.2 mm. length  
 22.5 mm. width  
 15.5 mm. depth

Left shaft + distal left ulna

animal type: Gallus dom. L., chicken  
 fragment size: 79.5 mm. length  
 11.0 mm. width  
 6.9 mm. depth



Room 4, unit 3, sec. 1: Right proximal tibia shaft; both ends sawed off. The distal cut is perpendicular to the shaft while the proximal cut is on the diagonal.

animal type: Sus scrofa dom. L., domestic pig  
 fragment size: 58.0 mm. length  
                   21.8 mm. width  
                   17.5 mm. depth

Small vertebral fragment. Saw cuts perpendicular to body.

animal type: unidentifiable  
 fragment size: 8.0 mm. length  
                   12.0 mm. width

Room 4, unit 1, sec. 1: Intrusive rodent bones

Room 4, trench 3, sec. 2: Right femur, whole.

animal type: Gallus dom. L., chicken  
 fragment size: 87.0 mm. length  
                   18.0 mm. proximal width  
                   8.0 mm. diaphyseal width  
                   18.5 mm. distal width  
                   12.5 mm. proximal depth  
                   8.0 mm. diaphyseal depth  
                   14.8 mm. distal depth

Room 4, trench 3, sec. 2: Left femur shaft section. Two perpendicular cuts bisecting the shaft.

animal type: Bos taurus L., domestic cattle  
 fragment size: 20.0 mm. length  
                   43.0 mm. width  
                   42.0 mm. depth

Room 4, north extension: Femur shaft fragment; two perpendicular cuts bisecting the shaft.

animal type: Bos taurus L., domestic cattle  
 fragment size: 12.0 mm. length  
                   65.0 mm. width  
                   44.0 mm. depth

Right tibia shaft; broken both ends

animal type: Gallus dom. L., chicken  
 fragment size: 82.0 mm. length  
                   8.0 mm. width  
                   8.5 mm. depth

Room 4, trench 1 extension (between tr 1 & U2): Scapula fragment,  
 possible modified; one surface appears to have been rubbed  
 smooth yet no polish.

animal type: large mammal  
 fragment size: 47.0 mm. length  
                   26.5 mm. width  
                   10.0 mm. thickness

Humerus shaft fragment. Two perpendicular cuts bisecting  
 left distal shaft.

animal type: Bos taurus L., domestic cattle  
 fragment size: 9.5 mm. thickness  
                   56.3 mm. width  
                   46.5 mm. depth

Caudal vertebra

animal type: Canis familiaris L., dog  
 fragment size: 33.0 mm. length  
                   23.0 mm. width

Room 4, trench 1, extension, 105-130 cm.: rib fragment. Severed  
 by perpendicular saw cuts to axis.

animal type: unidentifiable  
 fragment size: 91.8 mm. length

Left femur shaft. Distal diagonal cut and a perpendicular cut  
 bisecting the shaft.

animal type: Bos taurus L., domestic cattle  
 fragment size: 29.0 mm. thickness at center  
                   51.0 mm. width  
                   49.0 mm. depth

Right humerus shaft. Two perpendicular cuts bisecting the  
 shaft. Juvenile.

animal type: Bos taurus L., domestic cattle  
 fragment size: 23.4 mm. thickness  
                   66.0 mm. width  
                   29.0 mm. depth

Room 4, Trench 1, extension: Humerus shaft fragment: Two perpendicular saw cuts bisecting the shaft (coronal plane). Juvenile.

animal type: Bos taurus L., domestic cattle  
 fragment size: 20.3 mm. thickness  
                   60.0 mm. width  
                   26.0 mm. depth

Former excavated area immediately west of Classroom 4: Thoracic vertebra. One perpendicular cut bisecting the body (coronal plane).

animal type: Sus scrofa dom. L., domestic pig  
 fragment size: 20.0 mm. length  
                   37.5 mm. width

Room 3, sec. 2, 0-20 cm.: Left humerus; whole.

animal type: goose?  
 fragment size: 131.0 mm. length  
                   39.0 mm. proximal width  
                   15.3 mm. diaphyseal width  
                   29.5 mm. distal width  
                   20.5 mm. proximal depth  
                   11.5 mm. diaphyseal depth  
                   16.0 mm. distal depth

Room 3, sec. 2, level 2: Vertebral fragment.

animal type: unidentifiable  
 fragment size: 28.0 mm. length  
                   39.5 mm. width

Room 3, sec. 3, 70-90 cm.: Burned rib fragment.

animal type: unidentified  
 fragment size: 20 mm. x 13 mm.

rib fragment, broken.

animal type: unidentified  
 fragment size: 27 mm. x 9 mm.

Burned radius shaft fragment.

animal type: unidentified  
 fragment size: 17.5 mm. x 8.2 mm.

Three small burned rib fragments

animal type: unidentified

Caudal vertebral fragment, broken. Part of body remaining

animal type: bird-unidentifiable  
fragment size: 24.5 mm. length  
10.0 mm. width

Long bone fragment

animal type: unidentifiable  
fragment size: 20.0 mm. length  
15.5 mm. width

Burned left scapula fragment. Dorsal surface partially smoothed. Distal cut perpendicular to bone axis. Articulation recently separated; sub-adult.

animal type: unidentified  
fragment size: 20.0 mm. length  
24.5 mm. width

Scapula blade fragment. One side has been cut with a band saw. No other markings observed.

animal type: cattle?  
fragment size: 75.0 mm. length  
36.0 mm. width

Left scapula fragment with each end having a perpendicular saw cut to bone axis.

animal type: Bos taurus L., domestic cattle  
fragment size: 48.8 mm. length  
68.0 mm. width

Right tibia shaft with both epiphysis removed; saw cuts perpendicular to bone axis

animal type: Sus scrofa dom. L., domestic pig  
fragment size: 80.0 length  
21.5 diaphyseal width  
16.0 diaphyseal depth

Humerus shaft fragment; dorsal portion present

animal type: dog size animal  
fragment size: 20.0 mm. length  
16.0 mm. width

Burned fragmented vertebral disk

animal type: pig?  
 fragment size: 20.0 mm. length  
 14.0 mm. width

Room 3, trench 3 extension: Left proximal ulna.

animal type: goose?  
 fragment size: 27.3 mm. proximal width  
 15.0 mm. proximal depth

Room 3, sec. 3. 0-20 cm.: 2 unidentifiable bone fragments.

Right tibia shaft with both epiphyses missing. No saw marks observed.

animal type: Canis familiaris L., dog  
 fragment size: 59.0 mm. length  
 9.0 mm. diaphyseal width  
 11.0 mm. diaphyseal depth

Lateral metacarpal II fragment; split lengthwise. Ventral surface artificially smoothed.

animal type: Sus scrofa dom. L., domestic pig  
 fragment size: 53.5 mm. length  
 12.5 mm. maximum width

Distal tibia I, sub adult. Articulation only portion of bone remaining.

animal type: Sus scrofa dom. L., domestic pig  
 fragment size: 18.5 mm. width  
 17.0 mm. depth

Room 3, sec. 3, Level 2, 20-40 cm.: Femur shaft fragment; modified at both ends; no polish noted.

animal type: cattle?  
 fragment size: 51.5 mm. length  
 36.0 mm. width

Long bone cut coronal plane; fresh break in bone circumference.

animal type: unidentified  
 fragment size: 11.5 length  
 19.5 diaphyseal depth

First phalanx proximal articulation, sub adult.

animal type: Sus scrofa dom., domestic pig  
 fragment size: 19.0 mm. proximal width  
 17.0 mm. proximal depth

\* Room 3, sec. 3-4, 85 cm.: Distal left radius.

animal type: Bos taurus L., domestic cattle  
 fragment size: 81.0 mm. distal width  
 57.0 mm. distal depth

Room 3, sec. 4, 0-20 cm: Three bone fragments; unidentifiable.

Two vertebral fragments; no body. Both unidentifiable.

Trench 1, Play yard, 78 cm. depth, 147 E. 27 S.: Right proximal medial scapula fragment. There are three saw marks: One, which bisects the spine perpendicular to its axis 20 mm. from its anterior margin; Two, which runs perpendicular to this cut in line of the scapula axis; Third, a cut which is parallel to the first cut but is 54.0 mm. posterior (distal) of it.

animal type: Bos taurus L., domestic cattle  
 fragment size: 54.0 mm. length  
 56.0 mm. width at proximal end  
 26.5 mm. width at distal end

Room 2, Trench 1, 60 cm. depth, 63 cm. E. 54 in. N. from Room 1:  
 Rib fragment bisected by two diagonal saw cuts.

animal type: Bos taurus L., domestic cattle  
 fragment size: 104.0 mm. length  
 54.0 mm. average width

Room 2, Trench 1: Proximal left tibia. This bone represents a sub adult individual. Diaphysis is has been bisected by a saw cut perpendicular to its axis (coronal plane) 117.5 mm. from the proximal articular surface. The articular surface is characterized by a pitted surface which indicates that the proximal epiphysis is absent. There is also a fresh cut mark medio-laterally which was incurred during extraction from the soil.

animal type: Sus scrofa dom. L., domestic pig  
 fragment size: 52.0 mm. proximal width  
 42.0 mm. proximal depth  
 22.0 mm. diaphyseal width  
 32.0 mm. diaphyseal depth

Room 2, 25.5 cm. depth, 192 cm from beam on west side: Right astragalus. Apparently broken into three fragments during excavation.

animal type: Bos taurus L., domestic cattle  
fragment size: no accurate measurements can be taken.

Room 2, unit 1: Twelve burn fragments from a radius; immature-juvenile.

animal type: pig?  
fragment size: no accurate measurements can be taken

Scapula fragment having two saw cuts bisecting axis and also broken 36 mm. from the exterior margin. Piece too small for orientation.

animal type: unidentifiable  
fragment size: 14.0 mm. length  
36.0 mm. width

Distal right corocoid; shaft broken.

animal type: Gallus dom. L., chicken  
fragment size: 39.0 mm. length  
9.0 mm. width  
6.0 mm. depth

Two humerus fragments.

animal type: chicken?  
fragment size: cannot be measured accurately

Left proximal scapula; juvenile

animal type: Gallus dom. L., chicken  
fragment size: 14.0 mm. proximal width  
7.0 mm. proximal depth

Room 2, 140 cm. from beam between rooms 1 & 2, 18 cm. depth: Cervical vertebra bisected along its axis at a point laterally from the spine and the body leaving intact the foramen transversus. The cut was made by a saw. There is one modified area on the dorsal lateral surface; could have been made by saw.

animal type: Bos taurus L., domestic cattle  
fragment size: unable to measure it accurately

Room 2, 163 cm. from beam, 22 cm. depth, on west wall: First phalange, distal dorsal. Proximal area exhibits a fresh break.

animal type: Sus scrofa dom. L., domestic pig  
 fragment size: 28.0 mm. maximum length  
 19.0 mm. maximum width

Room 2, 24 cm. depth, 2 cm. from cut: unidentifiable bone fragment.

animal type: unidentifiable  
 fragment size: 30 mm. x 10.5 mm.

Room 2, 185 in. from beam, 25 in. depth, 3 in. from west wall: Left proximal femur, part of articulation present. Fovea capitis abnormally deep. Whole caput shows signs of bone reabsorption. Dorsal lateral section has been removed with a resulting saw cut along the axis of the femur. A related section of this femur positioned distally to the caput yet because of the bone condition cannot be attached exhibits a saw cut similar to the larger fragment. Age of the animal is senile.

animal type: Bos taurus L., domestic cattle  
 fragment size: 69.5 maximum length  
 36.0 maximum width of caput

Room 2, 127 cm. from beam, 27 cm. depth, 6 in. from west side of hole: Rib fragment which has been cut with saw along its axis; distally on one side and more proximally on the other.

animal type: cattle?  
 fragment size: 166.5 mm. length  
 16.5 mm. maximum width  
 21.0 mm. maximum depth

Room 1, test pit, north of Unit 1: Right humerus fragment bisected in the coronal plane; medial portion missing.

animal type: Sus scrofa dom. L., domestic pig  
 fragment size: 18.0 mm. length  
 43.0 mm. maximum width

Room 1, trench 2, 94 cm.-127 cm. south from room 2, 41 cm. depth: Two rib fragments; both have been broken. No cut marks observed.



animal type: Bos laurus L., domestic cattle

409 (no other provenience given): Burned humerus shaft fragment. This fragment has been bisected in the coronal plane. The cuts have been made by a band saw.

animal type: pig?  
 fragment size: 16.4 mm. length  
 49.0 mm. maximum width

School yard trench: Distal right femur; shaft broken. Right femur with epiphyses missing; broken off.

animal type: Gallus dom. L., chicken

Play yard, unit 3, 0-70 cm.: A sub adult proximal metacarpal III; domestic pig. A sub adult metacarpal IV; domestic pig. Right femur shaft segment severed at both end with a band saw; domestic pig.

East of trench 3 (2 feet) south of fence (3 feet): Right humerus; whole.

animal type: Sylvilagus sp.?, rabbit  
 fragment size: 67.5 mm. length  
 12.0 mm. proximal width  
 6.5 mm. diaphyseal width  
 11.5 mm. distal width  
 14.0 mm. proximal depth  
 6.0 mm. diaphyseal depth  
 8.0 mm. distal depth

Outer yard trench, unit 4: Vertebral transverse process with two cut marks. Cannot be measured accurately; animal type unknown.

Outer yard trench 3, feature 1: One reptile vertebra. Rabbit size rib fragment; broken. Broken right humerus; unidentified bird. Rib fragment, bisected in the coronal plane from domestic cattle.

#### Results and Conclusions

The bones from this sample resembled those from the initial group identified on 2 June 90. The inclusion of the dog and one addi-127 --

tional bird (still unidentified) are the only new animals. There were no abnormal butchering marks outside of saw cuts. A few of the bones had areas which appeared to have been caused by grinding on some surface. The actual surface or that these were also caused by a saw is indeterminable at this time.

Most of the bones are from adult individuals with the exception of two juvenile and one senile specimens from cattle, and three sub adult specimens from pig.

Butchering cuts on the shafts of long bones are normal occurrences from historic archaeological sites and from general butchering patterns even today. Yet to cut a long bone into small sections cutting in the coronal plane (perpendicular to the axis) is common practice today in the preparation of beef and pork steaks. It is unusual to find them in the context of the excavated material. Several other bone fragments exhibited unusual saw cuts which would not have aided in meat necessarily prepared for cooking. For example, a vertebral element near room 4, a vertebral element from the play yard, and prepared for cooking, and a femur element from room 4.

There is little or no differences in the type of bone found from the different areas. In the yard area one additional animal was identified; rabbit. There were no fish bones recovered. However, the occurrence of these bones within the context of the yard and trenches is unusual, thus it is unlikely they occurred randomly.

It is also interesting to note that the elements recovered from the different animals are uneven in their distribution. No teeth or skull material, no pelvis specimens, and only a few carpal bones. In the case of cattle there were no metapodial elements. From most archaeological contexts this sample would be considered atypical of kitchen midden material.

Because of the limited nature of the sample it is difficult to come to any further conclusions as to the age of deposition. Other data concerning site use and analysis of other related artifacts may in fact prove useful in ascertaining the source of the deposited bone. There is no doubt that man did butcher this bone. From an archaeological perspective it can be said that a whole these bones represent food remains. There are several questionable specimens, however, they too could be considered in the same category if taken as simply irregularities in the butcher-process.

*W. A. G. G. G.*

**APPENDIX I.5: Artifact Analysis**

by Mr. Jeff Minard

## HISTORICAL ARTIFACT ANALYSIS

### Introduction

This report presents lab and research findings regarding artifacts found underground at the site of the McMartin Preschool, Manhattan Beach, California. For purposes of this report, we divide these artifacts into two categories. The first is those artifacts excavated and discovered in loose association with other artifacts. The second is those artifacts physically connected to the structure of the McMartin complex.

The purpose of this report is to describe the physical characteristics of the artifacts found, and the results of related research into their dating. We do not interpret the meaning of these results in any larger context.

### Excavated Artifacts

Hundreds of items of various kinds were excavated from the McMartin site during the course of the project; many were simply trash, others were useful. From the project leaders, we received 41 of those excavated artifacts deemed to be of research significance. Most of these items are glass artifacts of general consumer origin. This section covers those items.

### Lab processing

We received the excavated artifacts beginning on May 6, 1990, continuing for about a month. Each item was already tagged with its control number, and either placed in a bag or with a tag attached, noting its provenance. We carefully processed one item at a time, retaining its provenance notes in association with each artifact. Full descriptions of each item cataloged can be found in Attachment 1.

The first step was washing the artifacts. Each item was removed from its bag and inspected for paper labels or material inside it. Any material found inside, such as soil or other substance, was removed dry and bagged and marked separately, if it was in danger of getting wet during washing. Closed bottles were left intact.

We washed each item in plain water, only using a brush if embossed lettering or other identification marks needed exposing, and only if no paper labels were present. Those items with paper label traces were either not washed with water, or were carefully daubed with a damp cloth to freshen any identification marks or lettering. All items were allowed to dry in the sun.

We painted the previously assigned control number on each piece with white paint. Many artifacts were broken, and each such

piece received a letter suffix, such as 200A, 200B, etc. We matched up disassociated broken pieces if they belonged to the same item, for example, 332C and 333A fit together to form a drinking glass. Such items were glued together to make handling and identification easier and more accurate.

#### ID process

Many of the items were easy to identify, since they had intact labels or the product name embossed into the glass, while others could not be identified at all.

The dating of individual items is very difficult. Products change labels and slogans often now, and less often during the earlier years of this century, but very little history has been retained by most companies regarding the evolution of their bottles and labelling.

The easiest way to get a general idea of the age and identification of bottles is to contact antique collectors and clubs. Therefore, we contacted members of the South Bay Antique Bottles and Collectibles Club for assistance. We did not inform these members that the artifacts were connected with the McMartin Preschool, but simply said that they had been dug up in Manhattan Beach and we wanted to identify and date them.

The members were very helpful, spending approximately 4 hours with us going over the 41 items listed in Attachment 1. The main thrust of the consultation was to date the items. In their collecting, the members had often found many similar bottles, and exhibited useful expertise on many of the items we found.

#### Results of Analysis

The final identification of each piece of glass, metal, or rubber is shown in Attachment 1. Dates are not included for each item.

Without exception, all bottles in the study date from the 1920's through the late 1950's (up to 1960), with the majority of them from the 1930's and 1940's.

The rusted metal can fragments (332D) cannot be identified, nor can the rubber tubes (333J, 333K).

After identification, all items were restored to their original bags or new ones, and returned to the project team.

#### Structural Artifact

Underneath Room 4 of the school was found a cast iron pipe that had attached to it a new-looking corrugated tin clamp. Since the item shined and did not look old, we received it for analysis and dating.

## Pipe Joint Clamp

The item is known as a pipe joint clamp. It has a main corrugated sheet metal portion, and two screw-in clamps to hold it fast, and it is manufactured of stainless steel, hence the shiny appearance. Two close-up photographs of the device are shown in Attachment 2.

The clamp has the following text debossed into it (along with other specifications):

NO-HUB  
PAT NOS  
2395273  
2452806

IDEAL CORP.  
ALL STAINLESS  
HYGEAR

ANACO  
U.S.PAT.NO.  
3233922

The clamp is still being sold by the Ideal Corporation of Florida. Anaco is a brand name.

## Patents

Patent number 3,233,922 was granted February 8, 1966 for a complete pipe joint clamp very similar in appearance to the artifact under discussion. The other two patents dealt with variations on the threaded-clamp concept, and were granted in 1946 and 1948. The general design has been around for decades, and this clamp represents some new improvements, but was not a breakthrough of any kind.

We provide a complete report of the last patent application, and abstracts of the previous ones, as Attachments 3, 4 and 5.

## Results of Analysis

In the plumbing business, like many others, inventors invent new products, manufacturers make them, distributors resell them to distribution points or directly to retail chains, and customers purchase them. A product can be made and sold through that process before a patent is granted ("Patent Applied For"), but it would obviously not have a patent number on it.

Since this clamp has a number on it, it was manufactured after the grant date of the patent. The question to answer is how soon could such a product pass through the chain of distribution and get into the ground on a job?

I checked with Mr. Joe Wiener, the Service Marketing manager at Ideal Corp. When asked if this could have been installed by September, 1966, he thought that was "unlikely". He did not believe Ideal would have records going back to the mid-sixties that would provide further data on the marketing of this exact piece.

Conclusions

1. The bottles and consumer products were probably all deposited at the site up until the 1950's, when residential development began taking place in that area.
2. It is possible, but unlikely, that the pipe joint clamp was installed at that site, between its manufacture after February 8, 1966 and the construction of the school over which it was found, in September, 1966.

Respectfully submitted,

Jeff Minard, President  
Trade Research Associates

Historical Artifact Descriptions

CONTROL NUMBER	HEIGHT Inches <sup>1</sup>	BOTTOM OR SIDE EMBOSSING (Repeatable Text)	PAINTED LABEL Text or Description	COMMENTS	PRODUCT ID
200ABC	(9)	NET CONTENTS 22 OZ	n/a	3 pc, amber beer, incomplete	beer
200D	(1x2-1/2)	n/a	n/a	broken piece, cir. ground base	vase
210	6 1/2	(b) IXL	illegible traces	prob. flavoring extract	extract
216	5 3/4	c in circle	illegible traces (n/a/blue)	8 sides, cap, pb. Horelick's	choc malt
217	10	(b) G 5	CIDER VINEGAR & traces	10 sided	vinegar
219	4 1/2	MOREHOUSE in pennant	n/a	cylindrical	mustard
221	5 1/2	Premier (b) 713	n/a	prob. pepper sauce	sauce
222	8	(b) O-Cedar	n/a	cork stopper piece	polish
230	7 3/4	(b) F&S LTD STH	n/a	English, green, prob. beer	beer
313A	3 3/4	(b) 6	n/a	druggist generic medicine type	medicine
313B	3 1/2	PHILLIPS MILK OF MAG., PAT. AUG 21 06	n/a	blue glass	medicine
313C	3 3/4	(b) 6	n/a	white powder, cork applicator	shoe polish
332A&B	(3 1/4)	(b) 7	n/a	2 pieces, like 313C	shoe polish
332C	(2 1/2)	star etched design	n/a	drinking glass, 1 pc. (see 333A)	drinking glass
332D	.	n/a	n/a	19 rusted can pieces	can(s)
333A	(3/4)	etched star	n/a	1 piece, Fils 332C	drinking glass

NOTES: 1. Heights in parentheses are broken pieces  
 (b) indicates lettering found on bottle bottom. No footnote means lettering found on side.



Historical Artifact Descriptions

CONTROL NUMBER	HEIGHT Inches	BOTTOM OR SIDE EMBOSSING (readable Text)	PAINTED LABEL Text or Description	COMMENTS	PRODUCT ID
333B	3 3/4	(b) 2	n/a	White substance inside	shoe polish
333C	1-1/4x3-1/4	B3	n/a	1 piece, threaded jar mouth	preserves?
333D	5 3/4	floral cut surface	n/a	Ornate vase, no base	vase
333E	1/2x2-1/4	(b) 979	n/a	White jar lid, threadless	cosmetics
333F	8	n/a	HEINZ CO, etc., mostly illegible	Heinz sauce	sauce
333G	1 1/4	57	n/a	Threadless stopper for 333F	sauce
333H	(1 1/4)	(b) 076 in diamond	illegible traces	1 piece of small bottle	medicine type
333I	2 3/4	n/a	n/a	Long thin tube	eye-drops
333J	1-1/4x1/4	n/a	n/a	1 piece flat rubber(?) tube	(unknown)
333K	1/4x1/4	n/a	n/a	1 piece flat rubber(?) tube	(unknown)
334	10 1/2	GARRETT, VIRGINIA DARE. FOOD PRODUCTS	n/a	Soda-shaped, 2 Pieces	sauce?
335	12	SCHWABAGER BROS. SEATTLE, WASH	COLUMBIA Pure Salad Oil	10 sides, dirt filled	salad oil
337	11 7/8	EWELL	illegible traces	14 sides, beverage type	selzer?
338	3 3/4	(b) 4	n/a	white powder, cork applicator	shoe polish
339	5 1/2	MOREHOUSE in pennant	n/a	8 sided	mustard
340	(4)	n/a	n/a	Goblet, 1 piece	goblet

NOTES: 1. Heights in parentheses are broken pieces  
(b) indicates lettering found on bottle bottom. No footnote means lettering found on side.

Historical Artifact Descriptions

CONTROL NUMBER	HEIGHT Inches	BOTTOM OR SIDE EMBOSSING (Readable Text)	PAINTED LABEL Text or Description	COMMENTS	PRODUCT ID
341	(3 3/4)	(b) S in diamond, arrowheads	n/a	piece, soda-type bottle	soda
342	3 1/2	(b) 358 in diamond	n/a	druggist generic medicine type	medicine
343	(2 1/2)	(b) DAGGETT & PAMSDSELL'S	n/a	1 piece	cold cream
345A	3 1/2	reverse 5	n/a	jelly jar as drinking glass	drinking glass
345B	3 1/2	reverse 5	illegible traces	jelly jar as drinking glass	drinking glass

NOTES: 1. Heights in parentheses are broken pieces  
 (b) indicates lettering found on bottle bottom No footnote means lettering found on side.

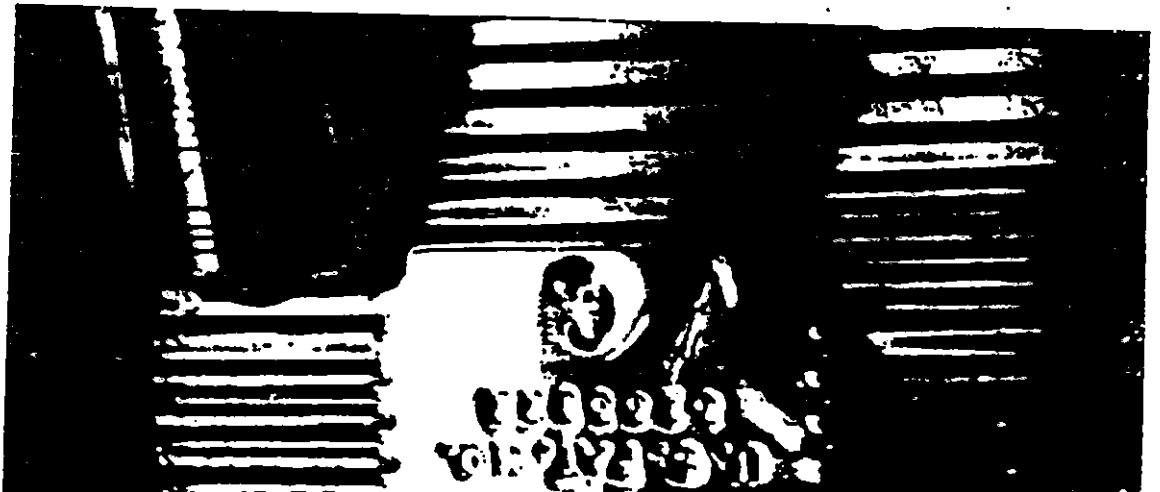
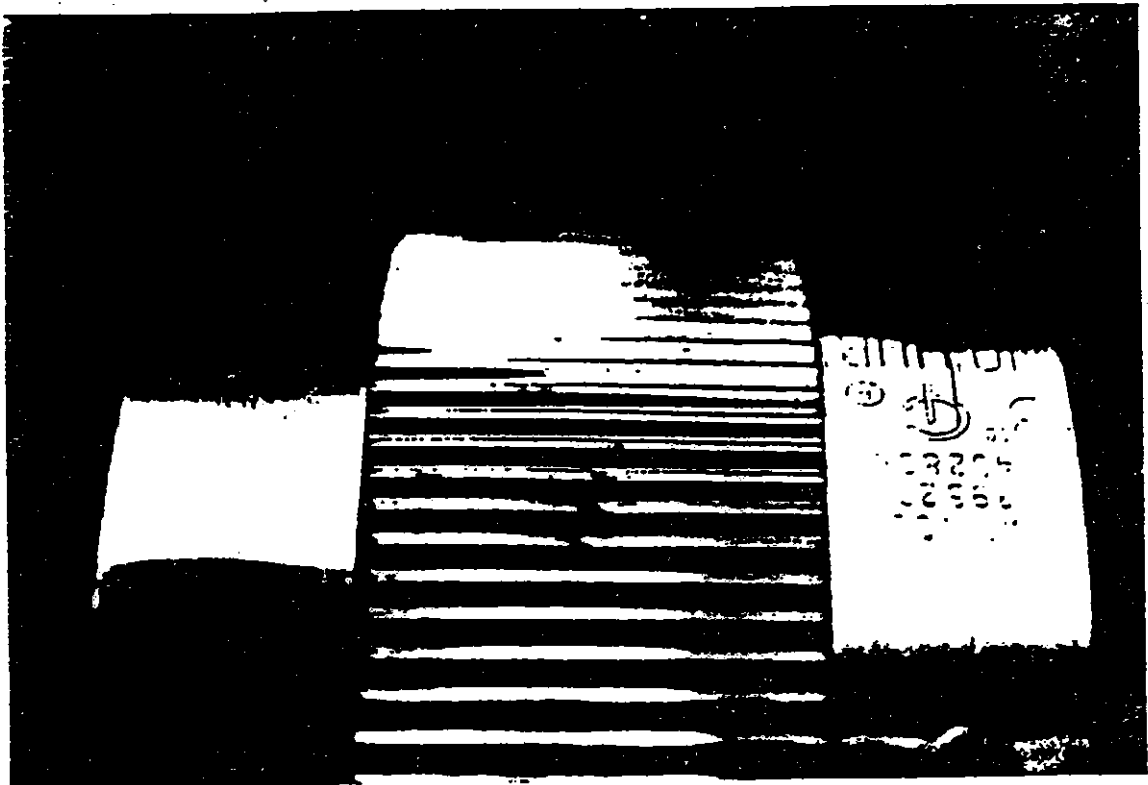

Feb. 8, 1966

G. EVANS

3,233,922

PIPE JOINT

Original Filed May 16, 1960

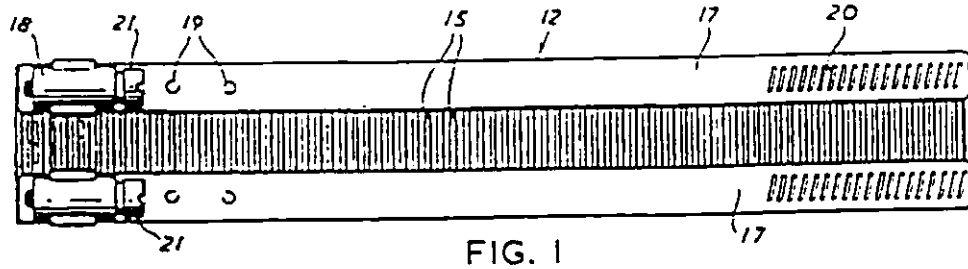

FIG. 1

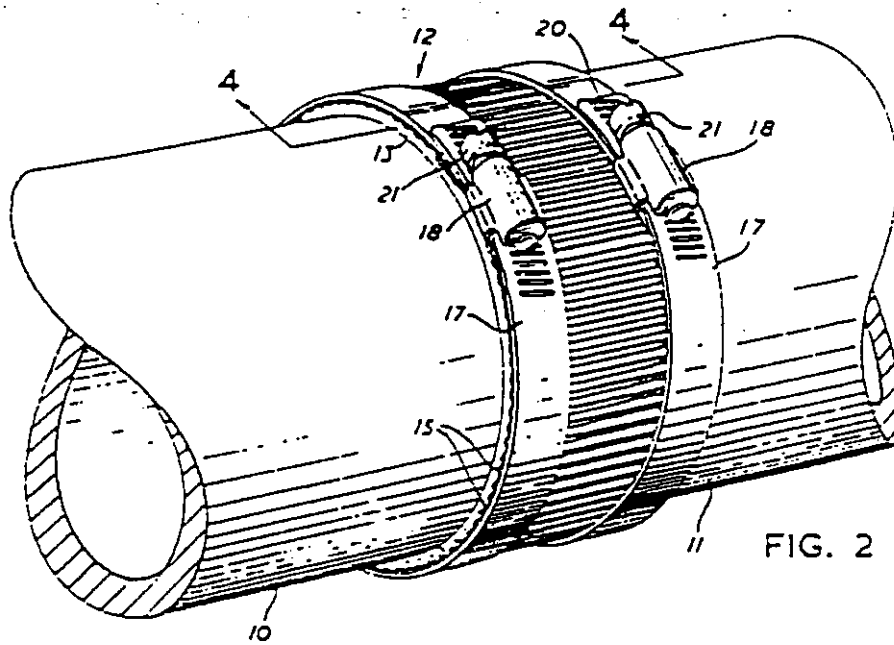

FIG. 2

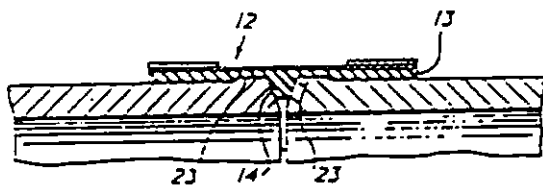

FIG. 4

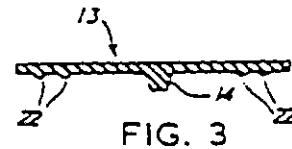

FIG. 3

INVENTOR  
GORDON EVANS  
BY: *Raphael Lemmas*  
ATTORNEYS

1

3,233,922  
PIPE JOINT

Gordon Evans, St. Catharines, Ontario, Canada, assignor, by mesne assignments, to Cast Iron Soil Pipe Institute, a general non-profit corporation of Illinois  
Continuation of application Ser. No. 29,383, May 16, 1960. This application July 29, 1963, Ser. No. 298,198  
1 Claim. (Cl. 285-236)

This application is a continuation of my copending application Serial No. 29,383, filed May 16, 1960, now abandoned.

This invention relates to pipe joints, and consists more particularly in new and useful improvements in a joint primarily designed for connecting aligned sections of cast iron pipe having identical ends. In other words, the joint of the present invention is not intended for pipe sections having complementary bells and spigots. It may be noted that while the joint is here described as used in connection with cast iron pipe, its construction and principle of operation may also be applied to joints for use with other types of pipe, including those formed of rigid plastic material.

In conventional sewer installations, domestic plumbing and the like, lengths of cast iron pipe are joined together with bell and spigot joints, and the joint is sealed by packing oakum in the hub or bell around the spigot, pouring lead over the oakum, and hand caulking until the joint is pressure-tight. In addition to being an expensive procedure, this conventional system is slow and has certain limitations of application, as well as presenting a fire hazard. The bell and spigot joint is also expensive in terms of the amount of cast iron required to extend a run of pipe over any prescribed distance. For example, when laying a straight run of 3" pipe over a distance of 20 feet with standard 5 foot lengths, five joints are required, and since there is an overlap of approximately 2 1/4" at each joint, a total of 11 1/4" of extra pipe length is required.

Furthermore, in order to provide sufficient strength to the bell portions of the joints, it is necessary to form the bells with a wall thickness greater than the wall thickness of the remainder of the pipe. The amount of extra cast iron required when the bell and spigot joint is used, is even more striking when one considers fittings such as elbows and Y fittings. For example, a 45° Y fitting has two bells at one end, and the other, or spigot end, must be long enough to allow a workman to get at the hub thereof to perform the caulking operation.

It is an object of the present invention to provide a joint for sections of cast iron pipe wherein caulking is eliminated, as the joint is designed to accommodate pipe sections having substantially identical ends arranged in alignment. Thus, by eliminating the necessity of the bell and spigot, there is a resultant reduction in the weight of the fitting. By the use of the present invention, the elimination of the bells and the shortening of the spigot end reduces the weight of a 3" Y fitting from 13 pounds to 6 pounds. This reduction in weight is important, not only from the viewpoint of economy, but also from the viewpoint of the workman who is required to lift and carry the pipe and fittings over prolonged periods of time.

In addition to presenting a fire hazard due to the use of molten lead when bell and spigot type joints are installed in buildings, these conventional joints have a further disadvantage in that the width of the bell very often prevents the installation of the pipe in places which would otherwise accommodate the pipe itself. For example, the standard size of pipe for house installation is 3" in inside diameter, having an outside diameter in the region of 3 and 3/4". However, the average outside diam-

2

eter of the bell for standard 3" is approximately 5". Thus, the pipe cannot be installed in a standard 2" x 4" stud wall, since the outer diameter of the bell exceeds the wall thickness.

It is therefore another object of the present invention to overcome these disadvantages and to provide a joint which may be assembled in standard 3 and 3 1/4" stud walls.

A further object of the invention is to provide a joint for cast iron pipes arranged in abutting relation or aligned longitudinally in end-to-end relation, including a joining unit which may be applied around the adjacent pipe ends to effect a pressure tight seal without appreciably increasing the outer diameter thereof, whereby the pipe may be installed in places where the presently used pipe cannot, due to the large size of the bell and spigot joint.

A still further object of the invention is to provide a joint which requires a minimum of time and no special tools for installation, yet providing a more flexible joint than that presently employed so as to allow the piping system to flex with the building when it settles.

A still further object of the invention is to provide a joint which insures proper alignment of pipes so that internal obstructions are eliminated and allows alterations and repairs without the destruction that is caused when repairing a plumbing system of the type employing bell and spigot joints. The joint of the present invention is also more suitable for underfloor installation and is easier to install in horizontal position than is the conventional bell and spigot joint.

Referring to the drawings in which numerals of like character designate similar parts throughout the several views:

FIG. 1 is a plan view of a clamping band and associated compressing straps of the invention;

FIG. 2 is a perspective view of an assembled pipe joint embodying the invention;

FIG. 3 is a cross-sectional view of a packing member used in the present invention; and

FIG. 4 is a sectional view taken on line 4-4 of FIG. 2, showing the relationship of the elements forming in joint.

As seen in FIG. 2, the pipe joint of the present invention is applied to two sections of cast iron pipe 10 and 11, arranged in end-to-end alignment, and includes a clamping band 12 which overlaps and surrounds the adjacent ends of the pipe sections. As best seen in FIG. 4, an annular, resilient packing member 13 is interposed between the band 12 and the pipe ends and bridges the latter, said packing member being of a width substantially the same as that of the clamping band 12 and provided on its inner surface with a centrally disposed, annular raised ridge 14 which fits between the aligned pipe ends to prevent actual contact therebetween. Thus, the clamping band 12 has the dual function of holding the pipe ends together to effect a joint, and of compressing packing member 13 tightly around both pipe ends to seal the joint.

The clamping band 12 is preferably made of high quality stainless steel to provide the strength and corrosion resistance required, and, as seen in FIGS. 1 and 2, is provided with a series of transversely extending corrugations 15 throughout its entire length. The corrugations 15 not only serve to strengthen the band so as to prevent undue flexing of the assembled joint, but also facilitate the successful joining of two pipe lengths of slightly different diameters. In this connection, it may be noted that during the manufacture of cast iron pipe, inaccuracies sometimes occur both in the pipe diameter and in the shape of the pipe, with the result that the diameter might vary as much as 1/16 of an inch from the standard size, or the pipe might be somewhat oval in

3

cross-section. In the bell and spigot-type joint, the space between the outside of the spigot end and the inside of the overlapping bell is sufficient to accommodate most of these variances. However, when the bell and spigot system is eliminated as in the present invention, these variances must be otherwise accommodated, and the corrugated clamping band of the present invention is particularly suited for this purpose.

As previously stated, the corrugations 15 run transversely of the clamping band 12 so that when the band is applied to the adjacent ends of two pipe sections as in FIG. 2, the corrugations run longitudinally of the pipe, and if the pipe sections are of slightly different diameters, the area of the clamping band surrounding the larger pipe section will expand due to the flattening of the corrugations in that area. This expansion permits tightening of the clamping band about both pipe ends to the same degree with little or no danger of causing the band to buckle, which would otherwise occur with a completely flat band.

In the manufacture of pipe to be joined in accordance with this invention, it is preferable to form flanges 23 on the pipe ends, as shown in FIG. 4, to facilitate the resistance of the joint against forces tending to pull the pipe ends apart. In other words, these flanges 23 are engaged by the packing member as it is compressed so as to provide a firm gripping action. It may be pointed out that these flanges are not absolutely necessary and that a very strong joint can be obtained between two plain pipe ends or between a plain pipe end and a flanged pipe end. This latter arrangement will occur when an off-standard length of pipe is required for a custom fit, making it necessary to cut a standard length of pipe which, of course, would not have a flange.

The clamping band 12 is tightened about the adjacent pipe ends by the use of two tightening straps 17 adapted to encircle the band adjacent each of its longitudinal edges to seal the joint by compressing the packing member 13 about the respective pipe ends. An effective means for tightening the straps 17 about the bands 12 may comprise screw-type tightening units 18 which are affixed to one of each strap and are adapted to receive the opposite ends of respective straps which are provided with a series of inclined slots 20. The tightening units 18 include screws 21 which are rotatably supported in the units and spaced upwardly a slight distance from the respective straps. Thus, the slotted ends of the respective straps are received by the units 18 in overlapping relation to the opposite ends of the straps for engagement of the inclined slots 20 by the threads of screws 21. Preferably, the straps 17 are fixed to the band 12 at points remote from their slotted ends, as by welding or the like at 19, to maintain the proper positioning of the straps with respect to the band and to facilitate the handling of the assembly during installation. It is important, however, that a certain area of each strap adjacent its slotted end be free of connection to the band 12 to permit independent tightening of the respective straps without buckling the band 12. It is also important that the actual pulling effect in tightening the joint is accomplished solely by tightening the straps around the band 12 to compress the latter and not by a pulling of the band itself, which, of course, would cause a longitudinal tension with the resultant stretching out of the corrugations 15. Naturally, any tension which would pull out or flatten the corrugations would reduce the effectiveness of the clamping band both from the standpoint of reinforcement and its ability to accommodate pipe ends of slightly different diameters, as previously described. Thus, as seen in FIG. 2, as the screws 21 are turned, the slotted ends of the straps 17 are drawn through the units 18 and are thus tightened about the opposite edges of the band 12 with no longitudinal tension on the band itself.

4

As shown in FIG. 3, the packing member 13 consists of an annular band of rot-resistant rubber, preferably synthetic rubber having the annular ridge 14 extending centrally around its inner surface, as previously described, and one or more annular sealing rings 22 also on the inner surface and spaced inwardly from the edges of the packing member. In addition to preventing actual contact between the pipe ends to avoid their damaging each other as the joint is made up, the ridge 14 also insures the the pipe ends will meet squarely and that the packing member will be located in the center of the joint. Furthermore, the ridge 14 presents a greater thickness of rubber in that area most likely to be reached by liquids and gases passing through the pipe which, of course, adds to the maintenance of a tight seal over long periods of time.

Synthetic rubber appears to be the most suitable material for the packing member 13 since it has been found to be most resistant to the corrosion effect of the material normally found in sewage and drainage systems. However, should some material which might affect the deterioration of synthetic rubber enter the sewage system, the failure of the packing member 13 would, in most cases, be delayed indefinitely due to the increased thickness of the packing member 13 by the provision of the ridge 14.

Sealing rings 22 are formed integrally with and around the inside of packing member 13 to increase the pressure with which the packing member grips the pipe ends as clamping band 12 is tightened. The size and number of sealing rings can be varied in accordance with the requirements to be met to effect a suitable seal as the smoothness of the pipe exterior varies. Where the pipe surface is particularly rough, larger sealing rings will be required. As an alternative to forming sealing rings integrally with the packing member 13, clamping band 12 could be provided with similarly shaped annular indentations, the under surfaces of which protrude and engage the packing member 13 to effect positive line contact at selected points around the pipe ends.

Tightening units 18 may be provided with screws 21 of the "one-way" variety having the slotted heads so shaped that only tightening of the screws can be effected. This alternative is advantageous where the assembled joint is to be installed in an open location. Where the joint is likely to be tampered with, such as by children, it is more important to provide some means whereby the joint cannot be loosened. When it is desired to dismantle this type of joint, the operation could be performed by a properly equipped workman by cutting straps 17 with a cold chisel or hacksaw.

As previously mentioned, the joint of the present invention provides more flexibility than the bell and spigot type joint and this compensates for the settling of newly constructed buildings having a piping system incorporating the new joint. However, complete flexibility is not required, and, in most instances, would be undesirable. Accordingly, the joint of this invention has a certain amount of rigidity so as to withstand excessive transverse forces without buckling. This rigidity is supplied by the corrugations 15 which cooperate to give the band 12 a structural strength sufficient to resist forces which might cause the joint to bend past desirable limits. This joint is capable of flexing through small angles which might have to be accommodated as a building settles, but will strongly resist any tendency to bend further.

Also, by providing the corrugations 15, a very versatile joint is produced. It is the manner in which these corrugations flex to accommodate variances in pipe size and surface contour which provides one of the most important advantages of the present invention. This joint will work successfully on pipe which varies in size, shape and surface finish due to inaccuracies of manufacture and on or between flanged or plain end pipe.

form with the sole of a shoe, said plate provided with a plurality of spaced spike members extending from one face thereof and having oppositely disposed sole engaging clips marginally positioned



adjacent the toe end, the rear end of said plate formed as two marginal extensions, each of said extensions formed at the rear end with inwardly directed extensions adapted to overlap and formed at their outer ends with sole engaging clips.

2,395,271

**PRODUCTION OF MODIFIED FEATHERS**

Erik Havemann, Chicago, Ill., assignor to Burton-Dixie Corporation, Chicago, Ill., a corporation of Delaware

No Drawing. Original application May 29, 1939, Serial No. 276,443. Divided and this application February 31, 1940, Serial No. 326,012

1 Claim. (Cl. 8-9, 10)

In the novel process of chemically modifying by iodine the feather-substance of a body of feathers having a capacity for developing an objectionable odor to prevent the possibility of such occurrence, the steps of, and in the approximate proportions stated, soaking 300 pounds of feathers in 350 gallons of a 0.4% solution of iodine and water, containing sufficient sodium-iodide to keep the iodine in solution, for about 4 hours, separating the liquor and feathers, and then rinsing and drying the treated feathers, thereby rendering such iodized feathers incapable of developing an odor objectionable to the normal human sense of smell under such atmospheric conditions of temperature and relative-humidity as would create such an offensive odor in like feathers not so iodized.

2,395,272

**SAFETY RAZOR**

Jay T. Hillmann, Chicago, Ill.

Application November 24, 1943, Serial No. 511,558

10 Claims. (Cl. 30-60)

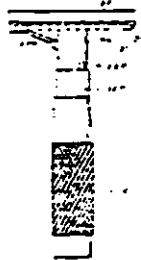

8. A safety razor holder, comprising a guard, a blade holder mounted for pivotal movement with respect to the guard to engage or release a blade thereon, a tubular member engaging the guard, a latch carrying member in the tubular member, said blade holder having a keeper extending through the blade and guard and engaged by the latch in the latch carrying member, means for moving the blade holder to an open position when the latch is released, and a toggle means for releasing the latch carrying member.

2,395,273

**HOSE CLAMP**

Frank L. Hill and Keith A. Hill, Rockford, Ill.; said Keith A. Hill assignor to said Frank L. Hill

Application August 17, 1944, Serial No. 549,835  
6 Claims. (Cl. 24-19)



1. For use in a hose clamp having an encircling metal band, a housing mounted on the band adjacent to one end thereof, and a tightening screw rotatably mounted in the housing and adapted to engage with the free end of the band, a means interconnecting the housing and the band comprising abutments on the band extending transversely thereof and means on the band forming recesses adjacent to said abutments, the base of the housing having a shape corresponding thereto and providing transversely extending abutments in abutting relationship to the band abutments to prevent movement of the housing longitudinally of the band and locking means extending longitudinally of the band and disposed in said recesses to prevent separation of the housing from the band.

2,395,274

**ISOMERIZATION PROCESS**

John C. Hillmyer and Harry E. Drennan, Bartlesville, Okla., assignors to Phillips Petroleum Company, a corporation of Delaware

No Drawing. Application January 22, 1942,

Serial No. 427,830

10 Claims. (Cl. 260-683)

1. A process for the selective catalytic conversion of aliphatic olefins of 4 to 8 carbon atoms to isomers of more highly branched chain structure while substantially excluding destructive reactions of cracking, dehydrogenation and polymerization, which comprises passing a hydrocarbon charge wherein the active hydrocarbons subjected to said conversion consist essentially of said aliphatic olefins of 4 to 8 carbon atoms in contact with a catalyst consisting of bauxite at temperatures in the range of from about 500° to about 1300° F. and at pressures ranging from about atmospheric to low super-atmospheric pressures for a reaction period in the range of from about 0.1 to about 10 seconds.

2,395,275

**COLLAPSIBLE CHILD'S CART**

Arch Robert Jackson, Bridgeport, Conn.

Application November 22, 1944, Serial No. 564,581

3 Claims. (Cl. 280-26)



1. A cart of the kind described, comprising a wheeled beam, a seat bottom comprising front and

V. means for supporting said element on said first support surface comprising a semi-circular recess in said element and a semi-circular support member mounted in said recess with the planar face on said member in engagement with the flat surface of said first support surface, and means for supporting said machine element on said second support surface and comprising a

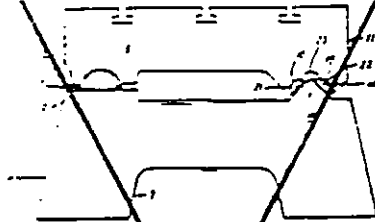

pair of independent support members, each support member having a surface resting on and slidable over one of said pair of surfaces, said machine element having a semi-circular recess therein on each side of said V to receive a semi-circular portion on each of said support members and to support said members independently of one another.

2,452,805

**COMPOSITION OF MATTER FOR SEALING SPOT-WELDED JOINTS**

Paul Sussenbach, St. Louis, Mo., assignor to The Pressite Engineering Company, St. Louis, Mo., a corporation of Missouri  
Application October 14, 1944, Serial No. 558,721  
1 Claim. (Cl. 106—193)

A sealing composition for use between metal parts to be spot-welded, comprising by weight approximately 17% of cellulose nitrate; approximately 30% of a fugitive solvent mixture comprising butyl acetate, butyl lactate, glycol monoethyl ether and glycol mono-methyl ether; approximately 48% of castor oil as a plasticizer, and approximately 5% of at least one electrical conducting material selected from the class consisting of carbon black and aluminum flakes dispersed therethrough.

2,452,806

**CLAMP**

Benjamin A. Tetzlaff, Riverside, Ill.; Lillian E. Tetzlaff, Ralph W. Tetzlaff, and Clarence C. Tetzlaff executors of said Benjamin A. Tetzlaff, deceased

Application April 14, 1944, Serial No. 531,061  
4 Claims. (Cl. 24—19)

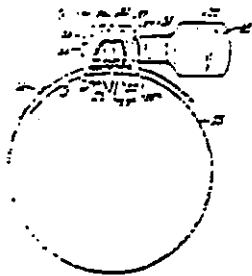

1. In combination, a housing for attachment to a band in a clamp device, having opposed end walls and a non-circular opening in one end wall thereof, a band-tightening unitary member extending through said opening and having a screw-threaded portion in the space within the housing between said end walls and a plain shank

portion extending through said opening, the end wall containing said opening being thin enough to permit it to pass between the convolutions of the screw thread during the rotary insertion of the screw threaded portion of said tightening member through said opening into the housing.

2,452,807

**SEALED REFRIGERATION UNIT**

Harry E. Thompson, Sidney, Ohio  
Application May 19, 1945, Serial No. 594,637  
8 Claims. (Cl. 230—58)

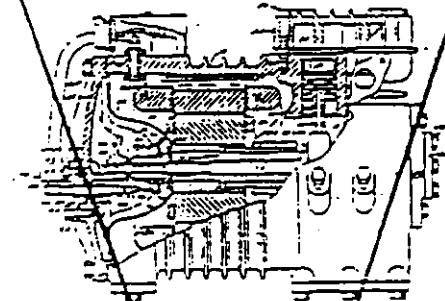

1. In a motor-compressor unit of the class wherein a motor and a compressor are sealed within a housing and are provided with a common operating shaft, the motor being of a type provided with a starting winding, the combination with said motor of centrifugally actuated mechanism driven thereby including a member movable axially of said shaft, a switch mounted upon the outside of said housing and connected in the series with said starting winding, a member projecting through an opening in a wall of said housing and mounted for pivotal movement about an axis extending transversely thereof, the outer end of the second-mentioned member lying in operative relation with respect to said switch and the inner end of said second-mentioned member lying in cooperative relationship with respect to said axially movable member, and means sealed to said housing and to said second-mentioned member sealing said opening against the flow of fluid therethrough between the interior and exterior of said housing, the relationship of said parts being such that when said centrifugally actuated mechanism is inactive said switch is in closed position and when said centrifugally actuated mechanism is active and said motor reaches a predetermined speed, said switch is open.

2,452,808

**BED SLAT**

Morris Tucker, Brooklyn, N. Y., assignor to Robert Tucker, Brooklyn, N. Y.  
Application December 4, 1946, Serial No. 714,019  
5 Claims. (Cl. 5—209)

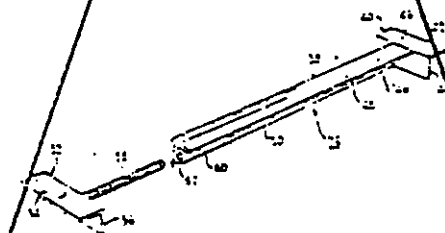

1. A slat comprising an elongated structural member, a bracket rigidly secured to one end of said structural member, said bracket including a



5

From the foregoing, it is believed that the invention may be readily understood by those skilled in the art without further description, it being borne in mind that numerous changes may be made in the details disclosed without departing from the spirit of the invention as set forth in the following claim.

I claim:

A pipe joint for joining two pipe sections in end to end alignment, comprising a clamping band of semi-stiff, flexible sheet material adapted to surround the adjacent ends of pipe sections to be joined, with the opposite longitudinal extremities of said band in overlapping relation, said band being provided with transversely extending corrugations throughout its length which, when said band is applied to the end of said pipe sections, extend longitudinally with respect to the latter, a resilient, annular packing member interposed between said clamping band and pipe ends, and bridging the junction of said pipe ends, compressing straps encircling said clamping band adjacent its respective longitudinal edges, separate strap tightening units fixed to one end of each strap, independent of direct connection to said clamping band for receiving the opposite ends of respective straps in overlapping relation, each of said straps being connected to said clamping band at one region only, said region

6

being adjacent said tightening units at points remote from said opposite ends, and means in each tightening unit for engaging said opposite ends of said strap and drawing the same through respective tightening units to thereby permit the independent compression of opposite longitudinal edges of said corrugated band and the underlying packing member around respective pipe sections to compensate for variations in the diameters or surface contours of two joined pipe sections.

#### References Cited by the Examiner

##### UNITED STATES PATENTS

131,843	10/1872	Brooks	85—45
607,018	7/1898	Connelly	285—45 X
1,833,776	11/1931	Dillon	285—365 X
2,890,899	6/1959	Simmons et al.	285—371 X
2,958,549	11/1960	Spafford	285—420 X

##### FOREIGN PATENTS

1,011,740	4/1952	France.
580,186	7/1945	Great Britain.
513,235	2/1955	Italy.

CARL W. TOMLIN, *Primary Examiner.*

**APPENDIX I.6: Electrical Analysis of the Preschool Building**

By Mr. Jeff Hellman

## APPENDIX I.6: Electrical Analysis of the Preschool Building ("Fire Alarm" System)

On May 4, 1990, Ted Gunderson documented what was represented as a "fire alarm" system in all of the classrooms (Classrooms #1, #2, #3 and #4). It consisted of a standard electrical wall switch with a crudely cut out arrow, stenciled "fire alarm" screwed onto the faceplate. Both were handpainted red. The actual light switch for each room was located approximately 3 ft. 10 in. from the floor, immediately next to the door of each classroom. It was noted that a child could reach these light switches without difficulty. However, the "fire alarm" switches were out of a child's reach in every case and were all about 4 ft. 6 in. above the floor.

The only bell was located above the office's west facing exterior door. Common red and white two conductor lead wire was wired into each classroom switch and connected in parallel to each classroom. The lead wire ran under the wooden overhang above the walkway and was attached by metal staples. Ultimately, the wire was traced to the attic above the office. A trap door was located just north of the south wall and in front of the interior wall of the office bathroom. The red and white lead wire was cut at that location and a step-down transformer was found, also disconnected, lying just inside the attic entrance, near the cut lead wire.

Mr. Jeff Hellman of G.S.E. Communications, a professional electronics expert, examined the system. His May 11, 1990, inspection is detailed in the following report.

APPENDIX I.6: REPORT ON FIRE ALARM SYSTEM

06-11-92

TO WHOM IT MAY CONCERN:

MR. TED GUNDERSON HAD ME GO TO THE MCMARTIN SCHOOL TO INVESTIGATE ANY TYPE OF ELECTRONIC SIGNALING DEVICES. A VERY INCLUSIVE SEARCH. INSIDE THE WALLS, CEILING AND GROUNDS AROUND THE BUILDING ONLY REVEALED AN INOPERATIVE FIRE ALARM, THAT HAD OPERATED ON 110 VOLTS WITH NO CAPACITY FOR A BATTERY BACKUP, AND COULD ONLY BE ACTIVATED BY MANUALLY TURNING ON ONE OF THREE SWITCHES. THESE SWITCHES WERE THE SAME TYPE AS THE LIGHT SWITCHES, AND MOUNTED CLOSE TO THE LIGHT SWITCHES. ONE COULD EASILY CONFUSE THESE SWITCHES FOR THE LIGHT SWITCHES.

THE ALARM SYSTEM APPEARS TO HAVE BEEN INOPERATIVE FOR MANY YEARS, AND OLD OUTDOOR BELL WAS THOROUGHLY RUSTED.

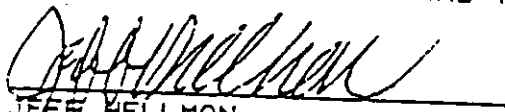

JEFF HELLMAN

(ALARM CO LIC # LQ 1449, BUREAU OF COLLECTIONS AND INVESTIGATIVE SERVICES)

## FIRE ALARM SYSTEM

On May 4, 1990, Gunderson measured and photographed what appeared to be a makeshift "fire alarm" system throughout the building. Red switch plate covers had been installed along with toggleswitches, and wired independently, above the regular Edison Company switch locations. (see figure 1, Appendix I.6). The covers were hand-painted.

The light switches themselves were placed next to the door of each classroom and measured 3' 10" above the floor. The red, "fire alarm" plates, however, were 4' 6" above the floor- higher than preschoolers would be able to reach. A crudely cut-out arrow stenciled "fire alarm" was screwed onto the switch plate, also hand painted red.

The only bell was located above the office's west facing exterior door. Common red and white one pair lead wire was wired into each classroom switch and connected in series to each classroom. The lead wire ran under the wooden overhang above the walkway and was attached by metal staples. Ultimately, the wire was traced to the attic above the office. A trap door was located just north of the south wall and in front of the interior bathroom wall of the office bathroom. The red and white lead wire was cut at that location and a step down transformer was found, also disconnected, lying just inside the attic entrance, near the cut lead wire

Gunderson contacted Mr. Jeff Hellman of G.S.E. Ccommunications, a professional electronics expert, to examine the system. His May 11, 1990, inspection is detailed in the following report.

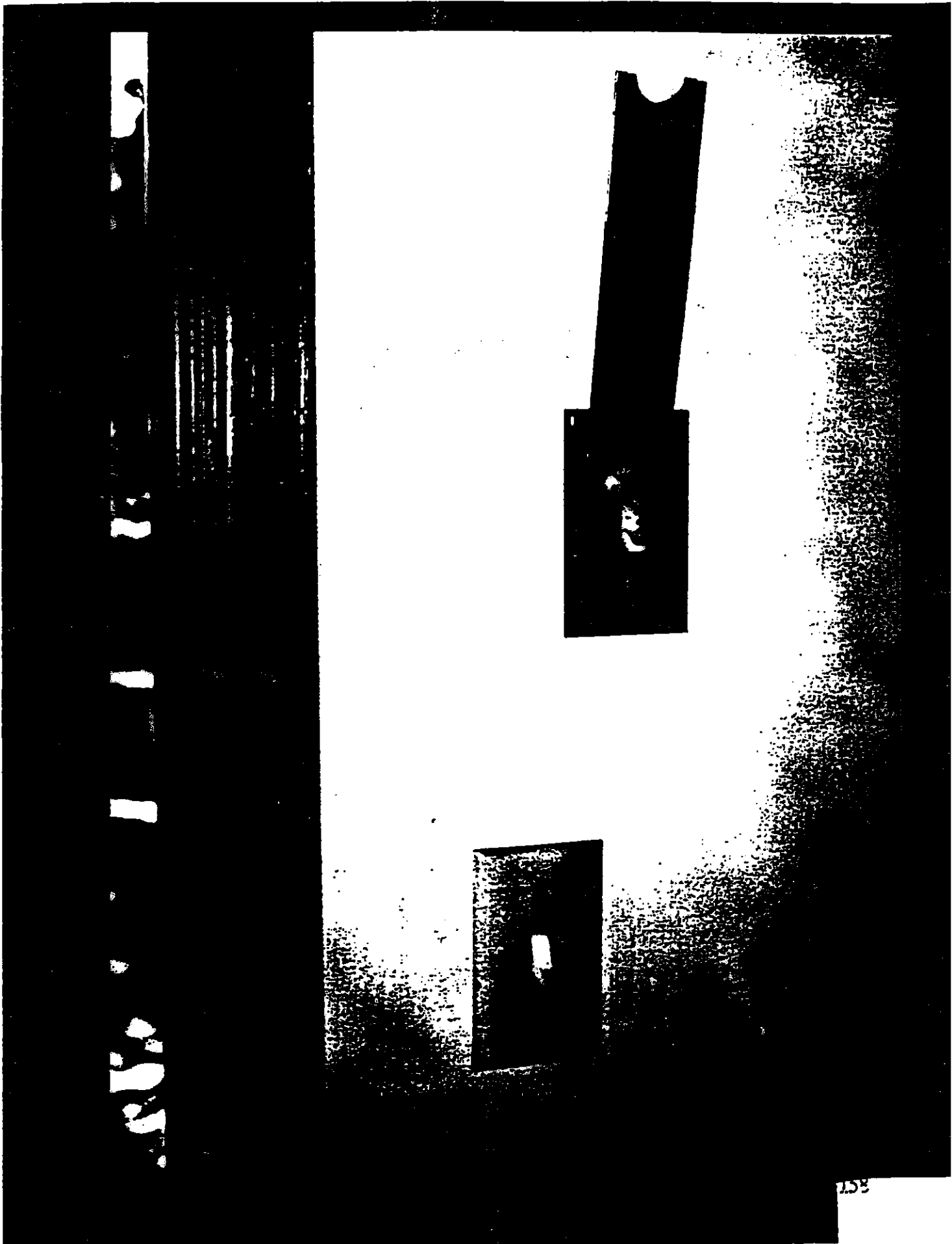

## **APPENDIX I.7: Ground Penetrating Radar Study**

RESULTS OF THE GEOPHYSICAL  
INVESTIGATIONS CONDUCTED AT THE  
McMARTIN PRESCHOOL IN  
MANHATTAN BEACH, CA

Investigation Conducted on May 8 & 11, 1990

<u>Contents</u>		<u>Page</u>
Introduction		1
Methods		1
Results		1
Figure One	Area of ground penetrating radar investigation on a portion of the McMartin Preschool Property in Manhattan Beach, CA	2
Figure Two	Typical ground penetrating radar profile from Area One.	3
Figure Three	Typical ground penetrating radar profile from Area Two.	4
Figure Four	Typical ground penetrating radar profile from Area Three.	5
Figure Five	Typical ground penetrating radar profile from Area Four.	6



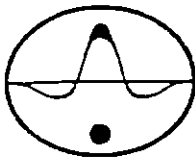

**SPECTRUM E.S.I.**

ENVIRONMENTAL SUBSURFACE INVESTIGATIONS

1475 CLADSTONE AVE. STE. 8 BURLINGAME, CA 94010  
P.O. Box 7728 FRENCH CREEK, CA 94530-9728

**RESULTS OF THE GEOPHYSICAL  
INVESTIGATIONS CONDUCTED AT  
THE MCMARTIN PRESCHOOL IN  
MANHATTAN BEACH, CALIFORNIA**

Introduction

On May 8 and 11, 1990 Spectrum Environmental Services, Inc. conducted a ground penetrating radar (GPR) investigation on the McMartin Preschool Facility located at 931 Manhattan Beach Boulevard in Manhattan Beach, California. The purpose of the investigation was to identify areas of disturbed soils which could indicate below ground tunnels.

Methods

Our approach was to conduct a GPR investigation to determine areas that may represent disturbed soils inside and adjacent to the pre-school building (see Figure One). Both north/south and east/west traverses spaced approximately five feet apart were established by Spectrum with GPR data collected continuously along each traverse.

The equipment used in this investigation included a GPR with a 300 and 500 MHz antenna.

Results

In Areas One, Two, Three, and Four, (see Figures Two, Three, Four, and Five) the GPR depth of penetration was approximately 8 to -10 feet below ground level. No evidence was found to support the existence of filled-in below ground tunnels.

*Donald J. Kirker*  
Donald J. Kirker  
Project Manager

**FIGURE ONE**

**AREA OF GROUND PENETRATING RADAR INVESTIGATION ON A PORTION OF THE McMARTIN PRESCHOOL PROPERTY IN MANHATTAN BEACH, CA**

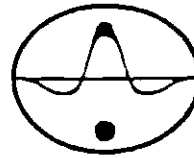

**SPECTRUM E.&I.**

ENVIRONMENTAL SUBSURFACE INVESTIGATIONS  
 1947 BLADFORD AVE. STE. 200 MANHATTAN, CA 94028  
 P.O. BOX 9728 MANHATTAN, CA 94028-0728  
 (415) 399-4371  
 (415) 399-7449

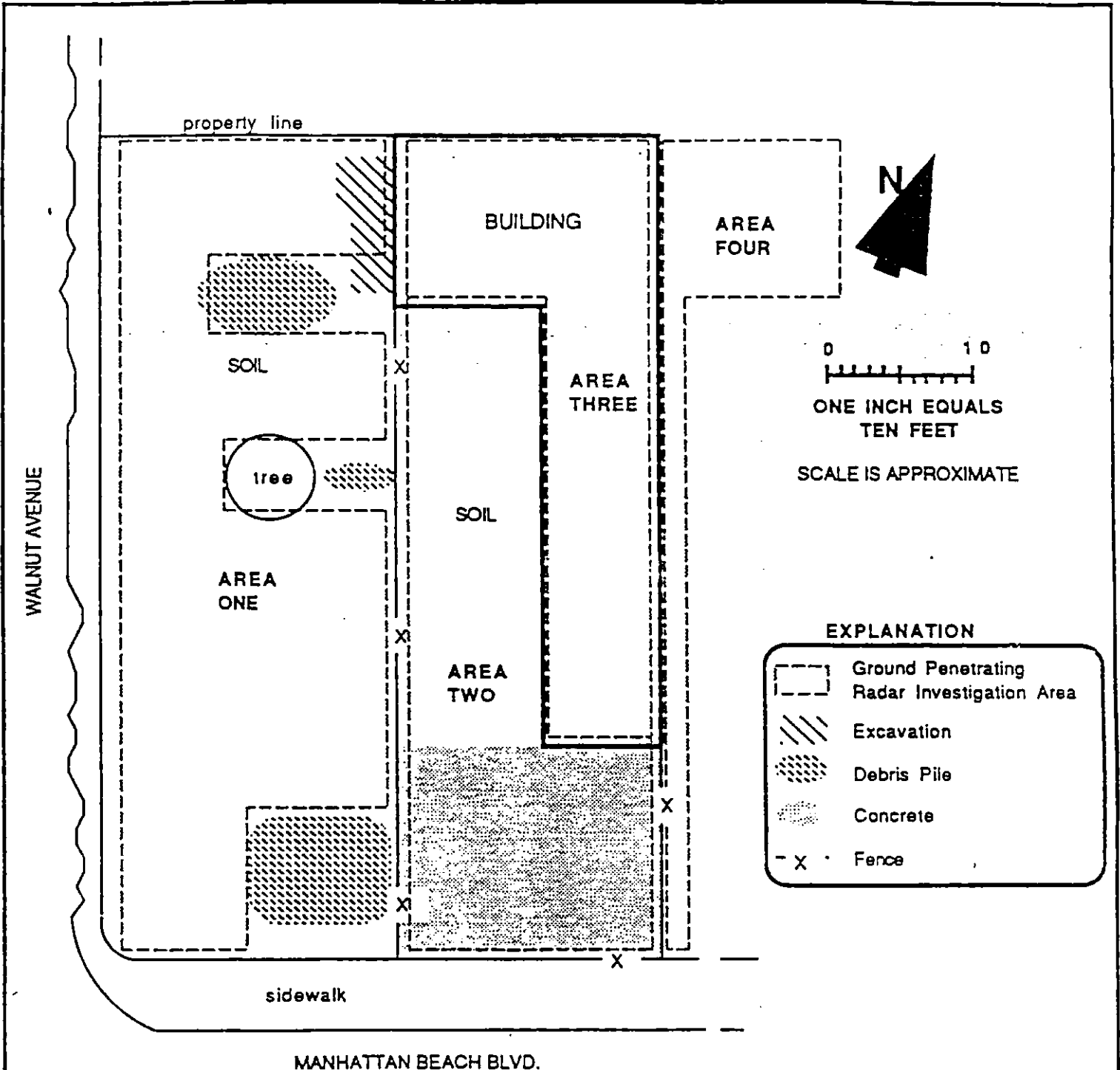

**EXPLANATION**

- Ground Penetrating Radar Investigation Area
- Excavation
- Debris Pile
- Concrete
- Tree
- Fence

90051101C  
 J. LeTourneau  
 Date of Investigation:  
 11 May 1990

\*Not all below ground facilities may be represented on this map.

Figure Two

Typical ground penetrating radar  
profile from Area One

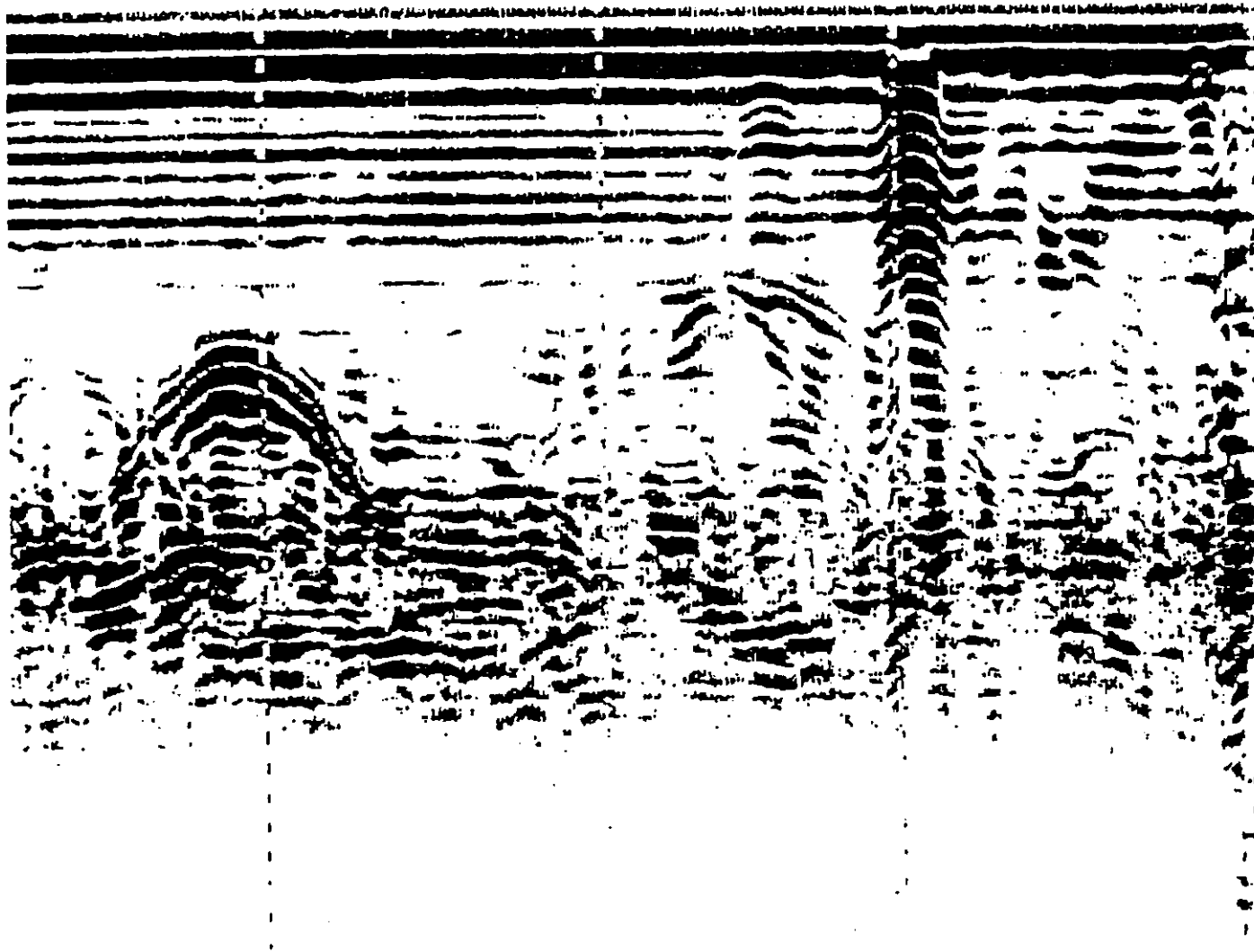

90051101C

10 feet between vertical dashed lines

Figure Three

Typical ground penetrating radar  
profile from Area Two

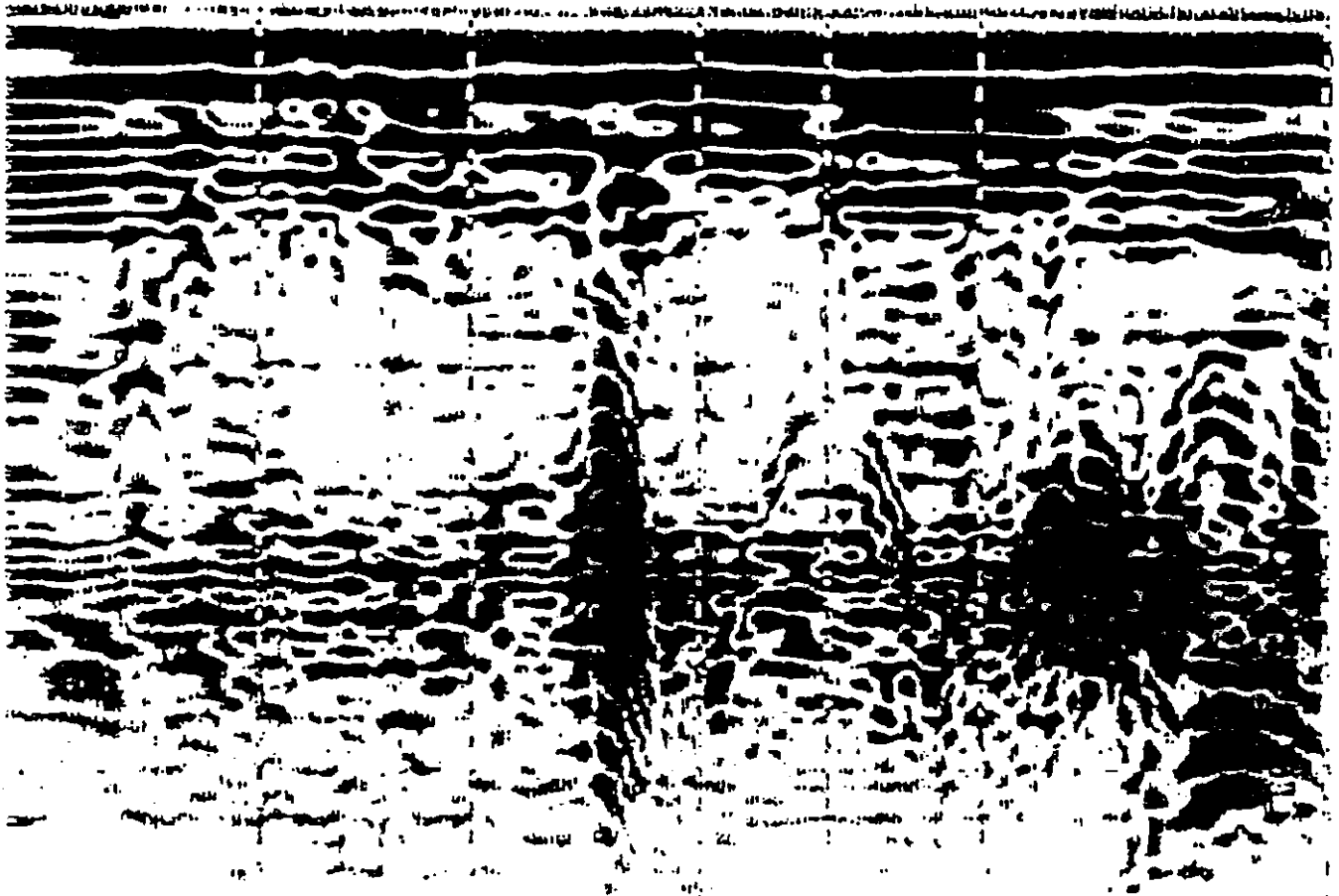

90051101C

5 feet between vertical dashed lines

Figure Four

Typical ground penetrating radar profile from Area Three

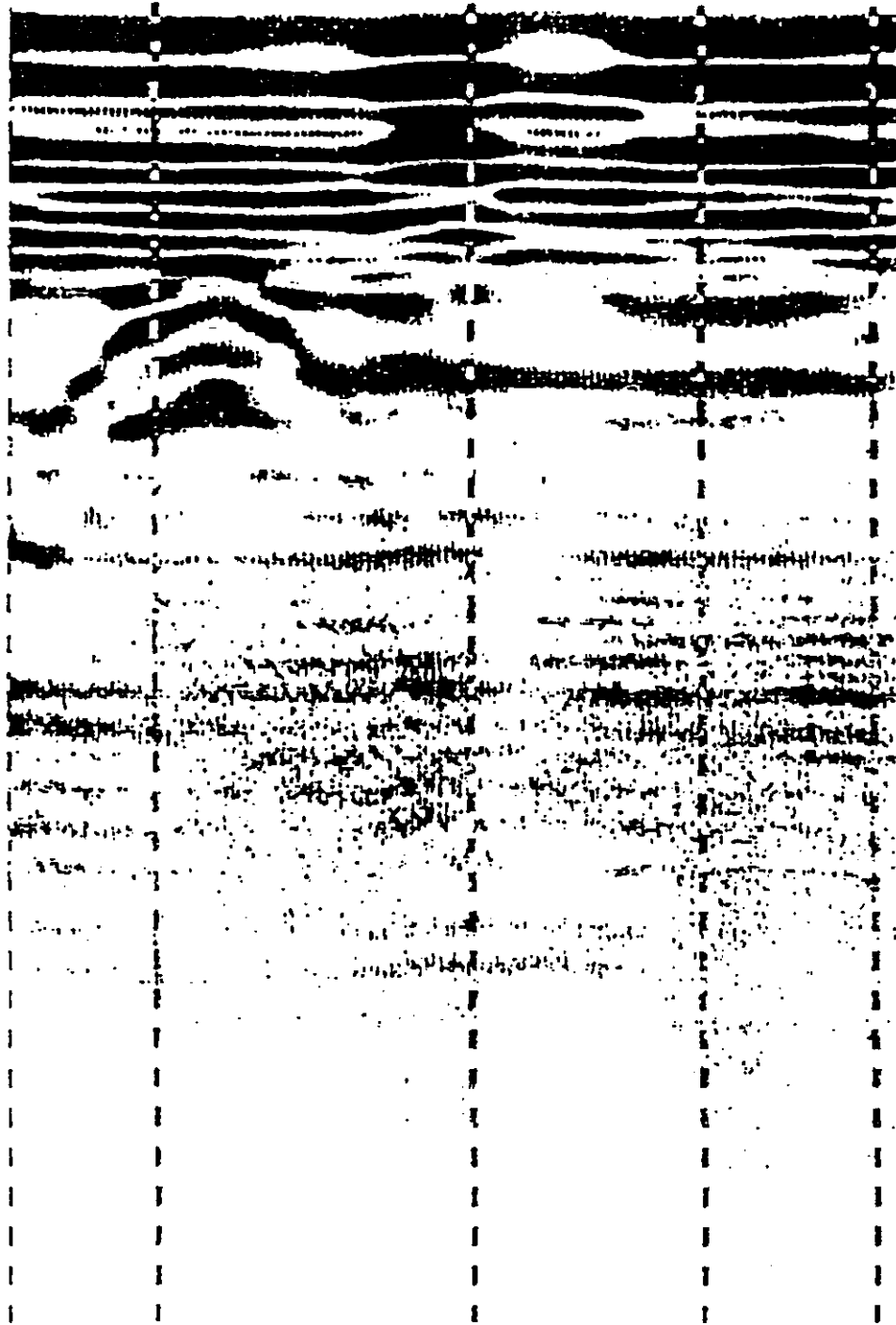

90051101C

5 feet between vertical dashed lines

Figure Five

Typical ground penetrating radar profile from Area Four

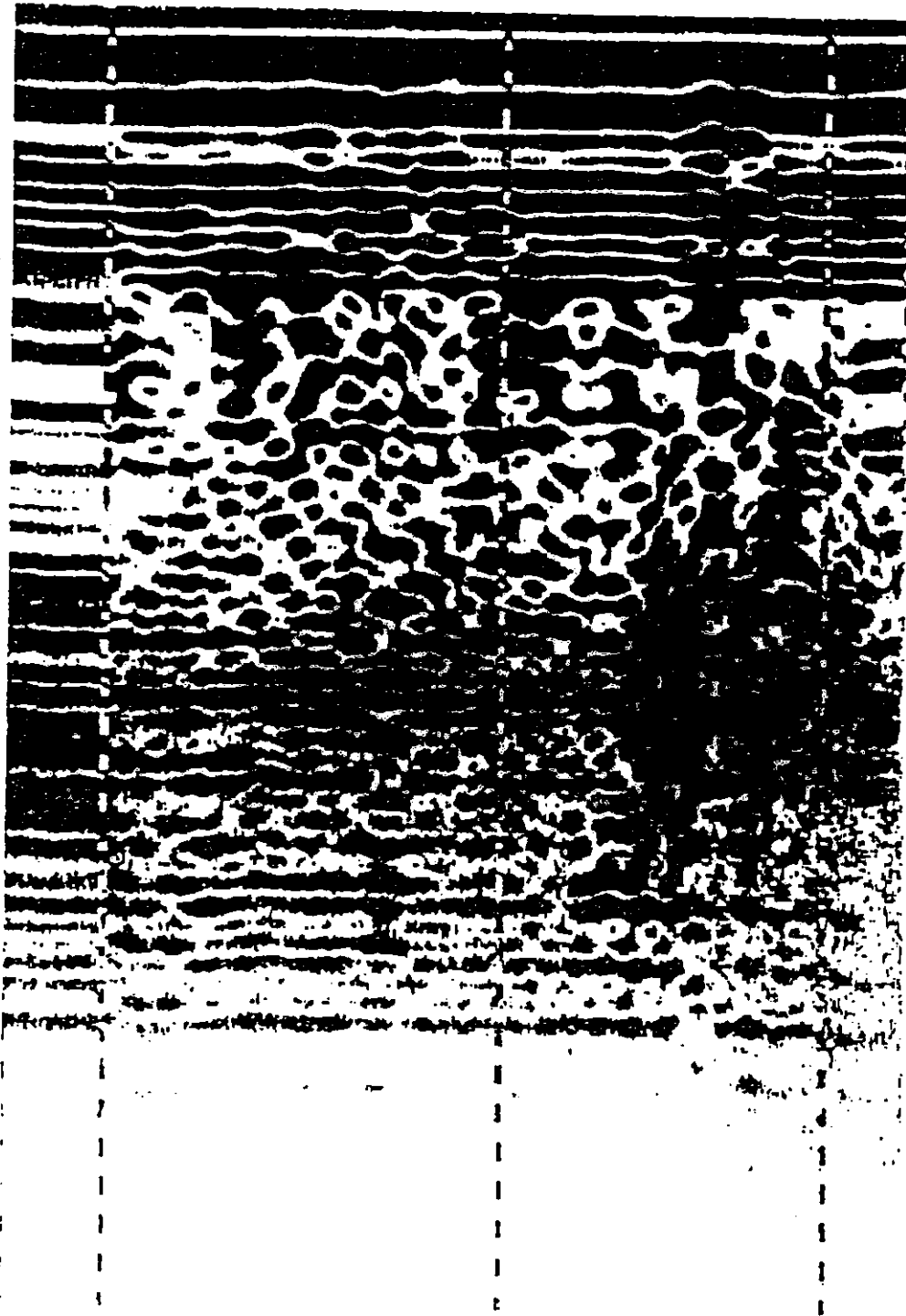

90051101C

10 feet between vertical dashed lines

## APPENDIX II: Therapist Survey

In order to determine what the children had said about the existence of tunnel(s) and/or secret room(s) prior to the 1990 archaeological project, an attempt was made to identify and contact therapists who had worked with children who attended the McMartin Preschool.

Because of the concern for confidentiality as well as the harsh criticism toward therapists involved with the treatment of ritual abuse survivors, it was rather difficult to locate therapists who had treated children from the infamous case. Thanks to the cooperation of one therapist who was to attend a meeting where she knew some of the involved therapists would also be in attendance, we ultimately were able to contact 10 therapists.

A sixteen question survey was sent by mail to the 10 therapists in May, 1992. Eight responses were returned. Two of those 8 respondents stated that none of their patients had disclosed anything about subterranean chambers or specific artifacts. Therefore, this survey will represent the six respondents whose patients disclosed information about the tunnels.

The six respondents represent 22 patients, both male and female. The ages and ratio of male to female patients is not known for this survey. One questionnaire was returned and filled out by a group of four therapists. This group represents 19 patients. The fifth respondent who treated 3 former students represents 2 patients because one of the three did not disclose about tunnels. The sixth respondent represents one patient. It is not known how many former students of the preschool were treated by the 10 therapists surveyed.

None of the therapists polled had any specific knowledge of the details or results of the project, other than, of course, what they may have heard in the media. Since most of the discoveries were made during the last few days of the project, the findings and results were not widely reported.

Following is the breakdown of the results of the survey.

SURVEY FOR McMARTIN TUNNEL DIG OF MAY 1990

1. Did patient state there was a tunnel(s) and/or a secret room under the school? \_\_\_\_\_ If so when? \_\_\_\_\_ & how many tunnels? \_\_\_\_\_
2. Where (if reported) did the patient say the tunnel(s) and/or room(s) were located? \_\_\_\_\_ Under the school? \_\_\_\_\_ if so, where under school? \_\_\_\_\_
3. What were the circumstances by which the patient claims he or she became aware of the tunnel(s) and/or room(s)? \_\_\_\_\_
4. Where did the patient say the entrance(s) to the tunnel(s) were? \_\_\_\_\_
5. Did the patient claim he or she was taken into the tunnel(s) and/or room(s)? \_\_\_\_\_ If so for what purpose? \_\_\_\_\_
6. Did the patient describe the tunnel(s) and/or room(s)? (i.e. exposed soil roof and walls or covered roof and walls with what materials)? \_\_\_\_\_
7. Did the patient mention plumbing pipes were visible in the tunnel(s) and/or room(s)? Any details of them (e.g. shiny things on pipes)? \_\_\_\_\_ Had to step over or hang on pipes? \_\_\_\_\_
8. Did the patient mention metal straps on the plumbing pipes? \_\_\_\_\_
9. According to the patient, what was the size (dimensions) of the tunnel(s) and/or room(s)? \_\_\_\_\_ Could adults walk upright or bent over? \_\_\_\_\_
10. Did the patient mention any type of clothing worn by adults during possible rituals in the tunnel or room? (e.g. hoods, capes, robes, masks, etc.). \_\_\_\_\_
11. Did the patient state how the tunnels or rooms were lit? \_\_\_\_\_ By what means (candles, electric lights, ) \_\_\_\_\_
12. Since we found animal bones in the tunnel and we want to see if there is any correlation, did the patient state if animals sacrifices were made at the preschool? \_\_\_\_\_ If so what animals? \_\_\_\_\_
13. Did the patient mention any symbols or signs seen by them? \_\_\_\_\_ If so what symbols? (e.g. a "star" or a pentagram)? \_\_\_\_\_  
Were the symbols on (clothing, plates, pendants, etc.)? \_\_\_\_\_
14. Did the patient mention if animal cages were used to disguise the entrance(s) to the tunnels? \_\_\_\_\_ Any details \_\_\_\_\_
15. Did the patient give information on any visits to the property (triplex) next door? \_\_\_\_\_ If so any details \_\_\_\_\_
16. Did the patient describe any furniture or objects of any kind in the room(s)? \_\_\_\_\_ If so what were they? \_\_\_\_\_

We thank you very much for your kind patience.



Survey Questions	Group of 4 therapists (n= 19 children)	Therapist #5 (n= 2 children)	Therapist #6 (n= child)
1. Did patient state that there was a tunnel(s) and/or secret room(s) under the school?  If so, when [did they make the disclosure?  How many tunnels?	yes= 19  1984-1987  two	yes= 2  March, 1986  -	yes= 1  -  one
2. Where were the tunnel(s) and/or secret room(s) located?  If so, where under the school?	under the school  they didn't know	under the school  McMartin & [named another school]	under the school  -
3. What were the circumstances by which patient claims they became aware of tunnel(s)/secret room(s)?	taken there by teachers	told they would be put in	___ took her there
4. Where did patient say the entrance(s) were?	in classroom; under playhouse; by the tree	stairs from --'s class went to tunnel	didn't specify
5. What was the purpose of tunnel(s)/secret room(s)	abuse; ritual ceremonies; to leave the school undetected	if bad, were punished there	killing animal
6. Did patients describe tunnel(s)/secret room(s)?	exposed soil roof & walls, covered roof & walls	no	no
7. Plumbing and/or pipes?	no	-	no
8. Metal straps on plumbing, pipes?	no	no	no
9. Size, dimensions of tunnel(s)/secret room(s)	some big, some small	didn't know	didn't say
10. Any particular clothing worn by adults?	robes	robes	black robes; masks
11. Did patient state if and/or how the tunnel(s) and/or secret room(s) were lit?	yes, with candles	light bulbs	candles; torches
12. Since we found bones in the tunnel, did patient state if animal sacrifices were made at school? If so, what animals?	yes, rabbits, turtles, cats	yes, bunnies, turtles	yes, turtles, rabbits, cats
13. Did patient mention any signs or symbols? If so, what?	yes, swastika, pentagram, "strange writing symbols," upside down crosses	yes, pentagrams	-
14. Did the patient mention if animal cages were used to disguise entrance(s) to tunnel(s)?	yes, rabbit cages over trap door	no	no
15. Did patient give any information on any visits to the property (triplex) next door?	yes, tunnel went there	no	no
16. Did patient describe any furniture or objects of any kind in the room(s)?	table, candle holders, chairs	no	table for sacrifices, bucket, bottle for blood

**APPENDIX III: Project Notes by Mr. Gerald E. Hobbs**

## APPENDIX III.1: Parents' 1990 Dig

Arrived on the premises at 8:00 a.m. and met with Ted Gunderson to inspect soil conditions around and under the school area. for possible past activity of previous digging of tunnels or underground rooms. I was directed to the NE corner inside the back of the school where there was a hole in the floor and digging had already begun. The hole was about 3' by 3' at the top and about 4 1/2' by 4 1/2' at it's widest point below, and 82" deep. The foundation was quite deep, 35" to the lip, and the lip about 1' wide 8" thick. It had been pounded and broken in the corner. At about 8:20 a.m. I entered the hole and swept the lip of the foundation into a bucket, to remove any foreign matter as to keep it from continuously falling in the hole. I dug the hole from 82" to 108" during the day, removing the soil with a small military type shovel and putting the dirt in buckets and handing it up to Ed or Bogie for sifting and analysis.

The procedures and notifications that I made while digging from 82" to 108" are as follows. I removed the dirt at the bottom of the hole from 82" level to 86" before I determined that it would most likely be free of any foreign matter from the top. There were small feeder roots 360 degrees around the hole from below the foundation to the level of 86" and they continued to the level of 98" and then ceased to be. At about 90" there was a larger root about 3" in diameter which ran along the west side of the hole, which was unusually straight for about 3'. It appeared to have been growing alongside of something solid and lacked a normal amount of feeder roots on its east side. In the N.W. corner at the end of the large root there was deteriorated wood in an upright position such as a 4' x 4' beam would set. It was broken and about 10" long. From 82" to 98" there were feeder roots in the wall, all around, but there appeared to be none in the 4' diameter of the hole. This leads me to believe that the dirt may have been removed in the 4' diameter area at one time, although I could not find any inconsistency in the dirt. This may be that the 4 1/2' hole is within the boundaries of a larger hole or that this is fill from before the construction of the building.

At 92" I located a small off-white button, at 100" a staple brad probably from a manila type envelope. Possibly not significant because of preconstruction fill, also what did appear to be a shard of glass at 96".

What did appear to be significant though was, what appeared to be charred pieces of wood from a prior fire, possibly the one in the school, itself. Also, there were flecks of light green paint and pieces of wood with light green paint. These two objects, char and paint were consistent from 86" to 108" of depth. I might add that the shelving in the room above the hole was of my opinion the same color of light green paint and had been broken and splintered. More excavation will need to be done to make a positive determination as to any prior excavation.

I then dug a 2' hole into the east, west and south sides of the hole at a level of 72" to see if there was an inconsistency in the soil to determine if there were walls to a larger hole, but could not determine. At about 3:00 p.m. I removed the dirt from the bottom of the hole that was there because of the holes in the side of the holes, it was also sifted.

April 26, 1990  
9:55 p.m.  
Gerald Hobbs



### APPENDIX III.2: Root Pattern Around Elm Tree

12:38 p.m. Did some minor digging around Evergreen Elm tree (25 to 30 years old) to determine if it had been dug around before. Found that at least one root (2" down) on west side had been chopped off about 1' from tree. It appears extensive digging has been done on north, east and west side of tree. South side of tree is sided with 9" of poured slab cement, and has a 4' root running along the under edge from west to east. Will give more evaluation on another day.

April 26, 1990  
10:15 p.m.  
Gerald Hobbs

### APPENDIX III.3: North Property Metal Detector Survey

Arrived on site at 1:00 p.m. I had a White's 5900 Mode Metal Detector with a T R or transmit and receive mode. It is used at times to find a void in the ground, what it's minimum depth's would be. I'm not sure but it would depend on the size of the void. I detected the walkway along the sand playground, also the patio area in front of school, also the walk on the east side of the school in the neighbor's yard. The results were negative, but, this is not conclusive as this instrument is not made for this use, particularly. Should be done with proton Magnetometer, have not been able to locate one. Completed this operation at 2:00 p.m.

At this time I continued the excavation on the [Elm] tree which had been started on the afternoon of 4-26-90. Upon digging around base of tree, it is found to have a mat of roots on the north side of tree, and assumably on the south side under the patio, also a mass of roots on the west side of tree but has had some major roots cut off at one time. What may be significant is the east side of tree. The roots are missing in an area about 4' wide and 8' long. They have either been cut close to the tree, or, more likely forced to grow in this pattern because of something of this size sitting below root level forcing these roots to grow in this abnormal pattern. In the rootless area there is a round cement foundation about 1' in diameter and at least 3' deep, it looks to be either a foundation for a cloths line or tetherball pole, but is inconsistent with the location of the tree. Because it is in the playground area it is probably a tetherball pole which I do not think would be only 4' from the tree. The tree, approximately 25 years old was probably planted at the time the school was built. I understand there was no dwelling on the site prior to 1966. If this is the case there would be no reason for this cement to be here. A remote possibility would be an air vent pipe to an underground void. It still has to be determined as to it's use. [It was later determined that this was in all probability an old flag pole. There was another flag pole that had more recently been used located south west of this old one. Because of the configuration of tree roots, it is still a possibility that there had been some other use for the pole.]

At about 4:00 p.m. I was summoned to go to the yard next door north of the school, where we proceeded to dig a hole with a gas powered auger. At a depth of 5' plus, the auger bound up, in what appeared to be a tough but not hard substance. At this time we could not get the auger out of the ground. It was necessary to dig down to the depth of 6' to get the auger released, to remove it. There was evidence that we had hit some type of wood object. Matching the wood chips by eye, it is possible they were from railroad ties. There were railroad ties in the yard to compare with. After digging with a shovel down to 7 1/2 feet, I did not hit any wood object. This made the seizure of the drill unexplainable except that it seized up in the sandy fill dirt we were drilling in. This seemed unlikely at the time because the sand is extremely soft. At any rate it was decided to leave the hole open for further observance, then later decided to fill it for safety precautions. More excavation to be continued at a later date.

Gunderson and I, at about 5:30 p.m., checked our notes to see that they were up to date. At about 6:00 p.m. I left the site.

4/30/90  
9:25 p.m.  
Gerald Hobbs

#### APPENDIX III.4: Disney Bag and Avocado Roots, Entrance to Tunnel

Arrived at school 8:55 a.m. Backhoe dug out trench about 8' deep on the west side of north wing at the rear of school. After the backhoe was finished, I entered the hole. The only object noticeable at that time was a plastic sack protruding from the dirt under the foundation about 26". I took a small garden shovel and probed the soil just under the foundation at 128" south from the north west corner of the building. From 10" to 16" below the foundation, objects started appearing. Bones of different types, rusty cans, bottles, which looked 1940's and older, also a douche nozzle, parts of a rubber hose, one which appeared to have a mouth piece at one end for inflation or a fitting grommet, also what appeared to be some small asbestos sheets. These objects were plentiful and at the time appeared remnants from a dump site. By this time the soil had dried some and a pattern of inconsistent soil started to appear. It was in a half moon shape measuring 44" below foundation where it became harder, 56" wide at the bottom and 91" at the top. At this time 26" below foundation and 124" from north west corner and 5" below the lowest point of the old cans and bottles I dug into the dirt 6" more to the east and removed a plastic sack which had been exposed by the backhoe. The bag had Disney characters on it and was dated: copyright 1982 and also a logo saying "class of 1982-1983" Disney. This seemed significant because it was 6" below other objects that were much older. At this time we stopped work to wait for geologist, Dr. Don Michael for corroboration of present finds. He arrived at 10:08 a.m. At this time we found 26" north of first find many of the objects that were in the first area and just above where the plastic bag was found. Also, running under the foundation from south to north was a large root which had been chopped off at the edge of where the large amount of cans, bottles, and plastic were being found. Roots were about 1 1/2" to 2" in diameter. They would have had to run in and through the cans and bottles, but did not. A space of 59" to the north, the roots picked up again, only these had been chopped off from the larger root and were dead. To me this is conclusive that with the inconsistent soil area, the plastic bag dated 1982, and the old bottles, cans and debris, were put in the ground after 1982, and it was not an old dump area as it appeared. Further excavation and sifting of soil should be done as soon as is possible. Also west and about 30 degrees from center of disturbed area and on opposite side of backhoe trench was more debris in the bank. Excavation in this area also is needed. In both cases the destination of the inconsistent dirt and fill should be determined. Below the floor of the building is what appears to be gravel for drainage and floor stability which is missing in at least one other area in the north east corner of the building. I believe this should be uniform through out the floor or not at all.

During the waiting period and chronological itemizing of the objects found, the backhoe excavated on the west of the south wing of building, also around the tree at south end of play ground and the retainer wall of fence at the north west corner of the play ground with my supervision. It is not inconclusive as to evidence that there has not been any major prior excavation in these areas. It may have to be done again at a later date.

5-2-90

9:25 p.m.

Gerald Hobbs

### APPENDIX III.5: Notes on Avocado Tree.

Tunnel entry at west end of room four, underneath the floor, running at approximately 30 degrees angle was a root from an avocado tree, located at the southwest corner of room 4. The tree, roughly 25 years old, had a main root running off it in a north easterly direction. At approximately 10' away and under the building floor. This root was severed at the south wall of the tunnel about 2' into the tunnel. The root was about 3" in diameter at this point. The cambium layer was from 1/3 to 1/2 healed over the severed end. Also new feeder roots growing at the end were from 8" to 14" in length. After 25 years in the tree business. I would determine the healing process would be from 4 to 6 years of growth, slowed by lack of direct water from the cover of the building floor. About 4' from the healing root on about a 30 degree angle was the north edge of the tunnel wall we located the severed end of the same root, from the same Avocado Tree. It was about 1 1/2" in diameter and continued in the same 30 degree angle as the other root, only this was dead and dry the cambium layer was separating from the rest of the woody part of the root, indicating it was probably severed at the same time the green root that was attached to the tree was severed. The dead root was reduced in size for approximately 4' along and a width of about 2' with it's feeder roots.

In this area was found a plastic Disney bag dated 1982 and a burning pit in line with the tunnel. The tunnel ran north and south along the west wall of room 4.

7-29-92

Gerald Hobbs

## APPENDIX III.5(a)

### Correspondence Clarifying Notes on Avocado Tree Roots

5-2-90

As a tree surgeon for a profession for 25 years, the determination of notes made on 5-2-90. Avocado Tree located at the southwest corner of the west wing of the McMartin preschool was approximately 25 to 30 years old, Probably planted from container 2-3 years of age and in the ground for 20-25 years. Determined by size of Avocado tree and rings in trunk, along with established root system, taking soil conditions, location of tree and average moisture seasonally into consideration as judgement of age.

One main root which grew below the foundation and floor of the west wing of school in 20 degree angle from west wall in north easterly direction had been severed with a hand saw about 90% through, then pulled off, peeling the bark of the root. The peeled area of the cambium layer had well established healing already in process. New feeder roots had started to grow from cut portion of root, and attained lengths from 6" to 15" in length. Both the feeder root lengths and the healing of the cambium layer indicate that the root had been cut at a time of 4 to 6 years earlier. This was consistent with the profile of an excavation going under the school, which we followed at great length throughout the school, determining the excavation of a tunnel and an underground room under the floor of two rooms in the west wing.

On opposite side of opening of filled tunnel or excavation approximately 4' to 5' was the remains of the main root, now dry and the bark peeling off, it was also avocado root in direct line from the main root which had been severed. The dead end had not started to rot, but the bark had dried and separated from root wood by about 1/8", indicating a 4 to 6 year old cut consistent with the live main root. I feel my determination is accurate due to my experience of the planting and removal and care of some of the same kind of trees for more than 25 years.

Gerald E. Hobbs



## APPENDIX IV: Notes on Investigation of the Neighboring Triplex

7-29-92

The children stated that they had entered a tunnel from the south east corner of room 1 at McMartin preschool. They indicated there had been a closet there at the time we started to dig it was a bathroom. We dug down along the east wall of room one and the bathroom. The plumbing coming up to the bathroom seemed out of code as though it had been done in two phases. From room one we picked up a disturbed area facing south and going in the direction under the north bathroom wall. As we followed the disturbed area south, it went under the wall into the now existing bathroom. after about 6 feet it made an abrupt right turn to the east and headed for the neighboring property.

The children had told two different stories about this tunnel prior to the dig. one, that they had gone through the tunnel and come up in the house next door and two, they had come up in the garage, which blocked the house from the street. At any rate the tunnel went in that direction. We contacted the owner, a doctor, he refused to let us dig, said he wanted \$350,000.00 to allow us to dig. He then agreed to let us dig as long as we did not dig close to the foundation of the house or garage. We followed the disturbed area east, after about 4' we hit a more recent disturbance where a sewer pipe or drainage pipe had been installed, this temporarily caused us to loose sight of the tunnel we were following. That evening I went to the house next door and followed the walk between the school and the house only about 4 1/2 ' apart. I went about 30' down between the buildings and found a crawl space under the house. I went under the house and bellied my way toward the southwest corner of the house. After going about 20' I found an area inside the west wall of the house where the floor was cut out. If I remember correctly the area of floor that was missing was 36" by 38" or 41", you could reach up and touch the bath tub which was exposed. The plumbing in that area appeared to be quite new. Most probably put in from the area that had caused us to loose sight of our original tunnel coming from the school.

I went back to the school and continued to dig past the pipeline trench at about 7'. I recovered the profile of the tunnel I had been following, it was now headed toward the corner of the house where I had found the hole cut in the floor. It was very close to the foundation of the house, I was sure, so I poked a hole up through to the surface, at that point I went into the yard of the house. The hole I punched through was about 2' beyond the east wall of the house and about 1 1/2' outside the south wall of the house. There was also a shrub along the south wall that had prior root damage leading under the south foundation. This tunnel was in direct line with the opening under the house.

G. E. Hobbs

EXPLANATION: Arrows indicate exposed location of bathroom

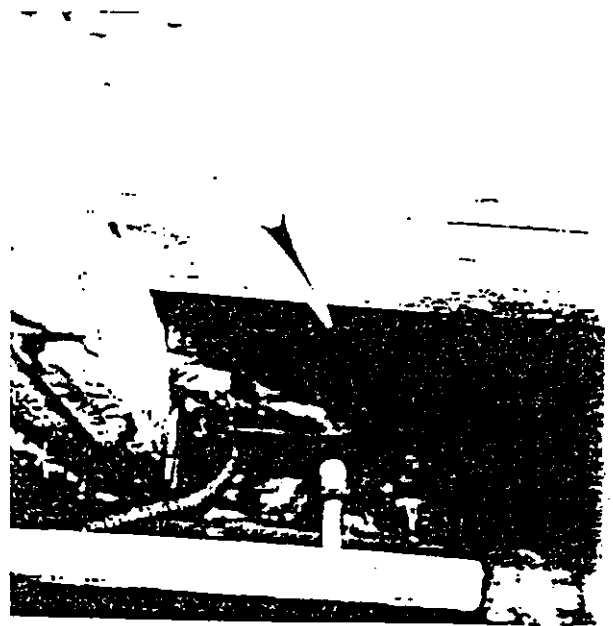
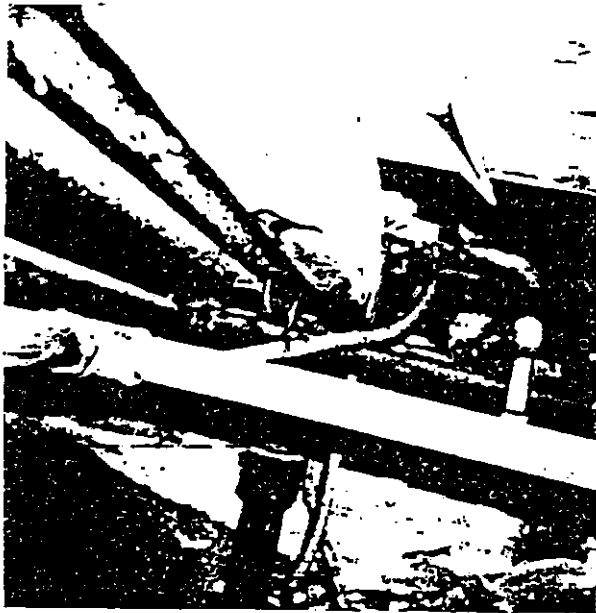

WALKWAY BETWEEN PRE-SCHOOL  
AND TRIPLEX SHOWING HOLES  
(Note Lemon Tree. Arrow  
Indicates Bathroom Location)



## APPENDIX V: Additional Project Notes

## APPENDIX V.1: Plumbing and Heaters

Jerry Hobbs excavated some additional material out of what was eventually identified as the entrance to the tunnel below the west wall of Classroom #4. Working west from the foundation 58 in. south of the northwest corner of Classroom #4 and at a depth of 46 in. from the surface, he recovered a eucalyptus pod, asphalt roofing paper, an egg shell, carbon, rust fragments, some bones, a broken bottle, shells, and green paint fragments. He dug down to what he thought was "original soil" at 53 in. (that is the bottom of an artificially excavated feature whose soil and artifact fill contents he had excavated out (Hobbs 1990).

Next Gunderson recorded that, exploring the area under Classroom #4 (i.e. below the preschool's concrete floor), he found aluminum foil, a red tile, and a rusted nail (Gunderson, 1990).

He also located a disconnected step-down transformer on the roof of the preschool. This was larger in size than the transformer associated with the "fire alarm" system.

He drew a floor plan of the school, drew the rooms and numbered the bathrooms (with the bathroom in the front office as his no. 1, bathroom; in Classroom #1 as no. 2; the bathroom in Classroom #2 was No. 3; the bathroom in Classroom #3 was No. 4; and the bathroom in Classroom #4 as No. 5). He also drew the locations of the outside drinking fountains (outside the Office and Classroom #2). He then removed the waste pipe from bathroom No. 3 (bathroom No. 3 was one location where some children said they had entered a tunnel). After the toilet was removed, he took some soil samples from bathroom No. 3. He then removed the waste pipes from all the remaining bathrooms and from the drinking fountains (Gunderson, 1990).

Next he noted the location of the three heaters on his floor plan and removed the heaters as exhibits. He noted the serial numbers of the heaters. Heater No. 1 (in the wall between Classroom #1 and the Office), had no serial number but the manufacturer was Gaffers and Sattler. Heater no. 2 (on north wall of Classroom #2) contained serial no. 4021 LN of Gaffers and Sattler. Heater no. 3 (between Classrooms #3 and #4) had serial no. 4185 of Gaffers and Sattler (Gunderson, 1990). He noticed a newspaper wrapped around the toilet waste pipe in bathroom No. 2 (Classroom #1) which was dated June 11, 1987.

It should be noted here that the preschool was entirely renovated for inspection by the jury on Wednesday, April 29, 1989. This, however, does not explain the presence of apparently new plumbing.

## APPENDIX V.2: Attempt to Age Concrete Floor

A stack of twenty or more unused, light brown asphalt tile, appearing to be exactly the same as the tile used throughout the entire interior floor of the preschool, was discovered in the cupboard under the kitchenette sink in the office. This discovery raised the question of whether or not the floor had been patched, or perhaps replaced in its entirety.

Several sections of tile were removed by the District Attorney's investigators in 1985 but the black mastic under the tile remained on the concrete slab. In order to check the preschool floor thoroughly for any patches or replaced areas of concrete, all of the tile would have to be removed and then the mastic would have to be sandblasted or chemically removed. Because of financial and time constraints, these ideas were quickly abandoned. We felt it was much more important to use our time trying to locate and identify any tunnels or rooms under the school.

Superior Concrete Company, Long Beach, California arrived at the site on April 30, 1990, to cut various samples from the floor of the preschool. This was done in an effort to check the consistency of the concrete mix, the age of the concrete throughout the building, to try and determine if the floor had been patched or replaced since 1966.

A concrete expert determined that there was no way to conclusively establish whether different samples were poured at different times or document its age. This approach was then abandoned.

### APPENDIX V.3: Classroom #3 Door

The outside door to classroom #3 had remained open throughout the project due to the activity in the parents' 1990 dig and the archaeologist's trenches. Several days into the project one of the workers noticed that classroom #3 did not have a door knob like all of the other outside doors. Instead, there was a single cylinder dead bolt with a flip latch on the inside, with only a key hole on the outside. Once latched from the inside, there could be no entry to this classroom without a key. The face of this door was obscured from outside view due to its placement within the inside corner of the L shape of the building, recessed behind the north wall of classroom #2 (see figure 1, page 5). The absence of any exterior knob was further obscured whenever the door was open, since the face of the door backed on to the dead end of the hallway.

Several parents remembered that when they were present at the school during operating hours, the door had always stood open. One mother with a two-year-old son, who was not enrolled at the preschool, stated that whenever she would visit, the baby would run into the vacant room and reach for the children's paint and brushes. The baby did this several times and each time the director would scold the mother and tell her it was not safe to let the baby go into the room because there were too many things he could get into. Yet the door was never closed.

The absence of a knob on the door to Classroom #3 is documented on video (KCAL Channel 9 newscast, May 9, 1990) and in the photograph on the following page.

APPROXIMATELY 10:00 AM, THE SUBJECTS WERE  
FOUND WITH NO DOOR KNOB AND  
A LOCK BOLT.



## APPENDIX V.4

### Disney Bag and Avocado Tree Roots: Final Observations

On July 13, 1993, a meeting was held with Mr. Paul E. Langenwalter to clarify essential measurements concerning the Disney bag and tree roots. Notes, charts, and photographs of the excavations conducted by Scientific Resource Surveys, Inc. (SRS) in 1985, by the parents in 1985 and by this project in 1990 were reviewed.

Mr. Langenwalter advised that the SRS excavation outside the northwest corner of classroom #4 was conducted in 1985 at the request of the Los Angeles County District Attorney's Office to determine the exact extent of the parents' excavation and to locate any additional animal remains in the vicinity of the parents' discovery of the tortoise shell. SRS excavated to a maximum depth of 30 cm. (13.5") a rectangular area encompassing and extending beyond the area where the parents dug. The SRS excavation extended 118" south of the northwest corner along the west wall of classroom #4.

The parents' excavation of 1985 included a series of backhoe trenches placed against the west wall of classroom #4 and extending at intervals southward (labeled 2, 3, 4, 5, 6 and 7 on Figure 4, p. 12). The northernmost of these cuts was close to the southern boundary of the SRS excavation. It was 28" wide, extending from 137" to 165" south of the northwest corner, beginning some 19" south of the SRS excavation.

The Disney bag was found 124" south of the corner, 42" below the ground surface, and 3" to 6" inside the wall line of the building, in the middle of the tunnel entrance fill. It was therefore beyond the scope of the SRS excavation in each of three dimensions, since the SRS dig terminated 118" from the corner, at a maximum depth of 13.5", and outside of the building's foundation. Since the parents' backhoe trench was no less than 137" from the northwest corner, it is clear that the plastic Disney bag was located by Hobbs in the virgin area between the SRS excavation and the parents' dig. In fact, it was recovered 7" south of the parameters of the SRS excavation and approximately 13" north of the parents' backhoe trench.

It is also clear that SRS did not cut the avocado tree roots at the entrance of the tunnel, as SRS did not excavate under the foundation of the west wall of classroom #4 where the roots were found by Mr. Jerry Hobbs (see Figure V.4b).



# TUNNEL ENTRANCE

## LOCATION OF PLASTIC DISNEY BAG IN RELATION TO TUNNEL ENTRANCE CLASS ROOM # 4

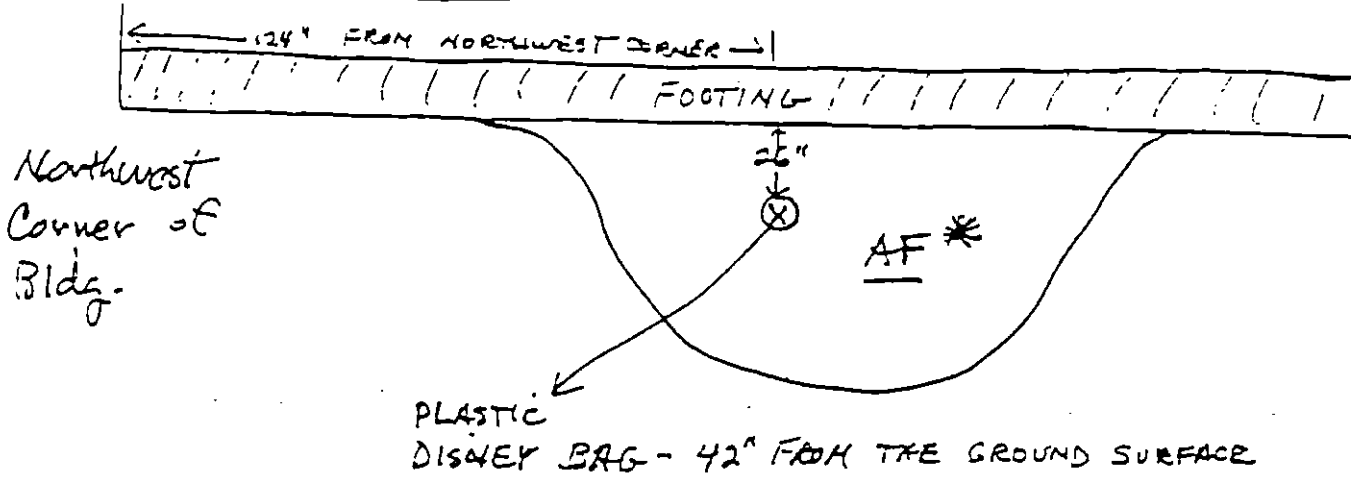

## EXCAVATION BY SRS AND PARENTS NORTHWEST CORNER OF CLASS ROOM # 4 (SEE FIGURE # 4)

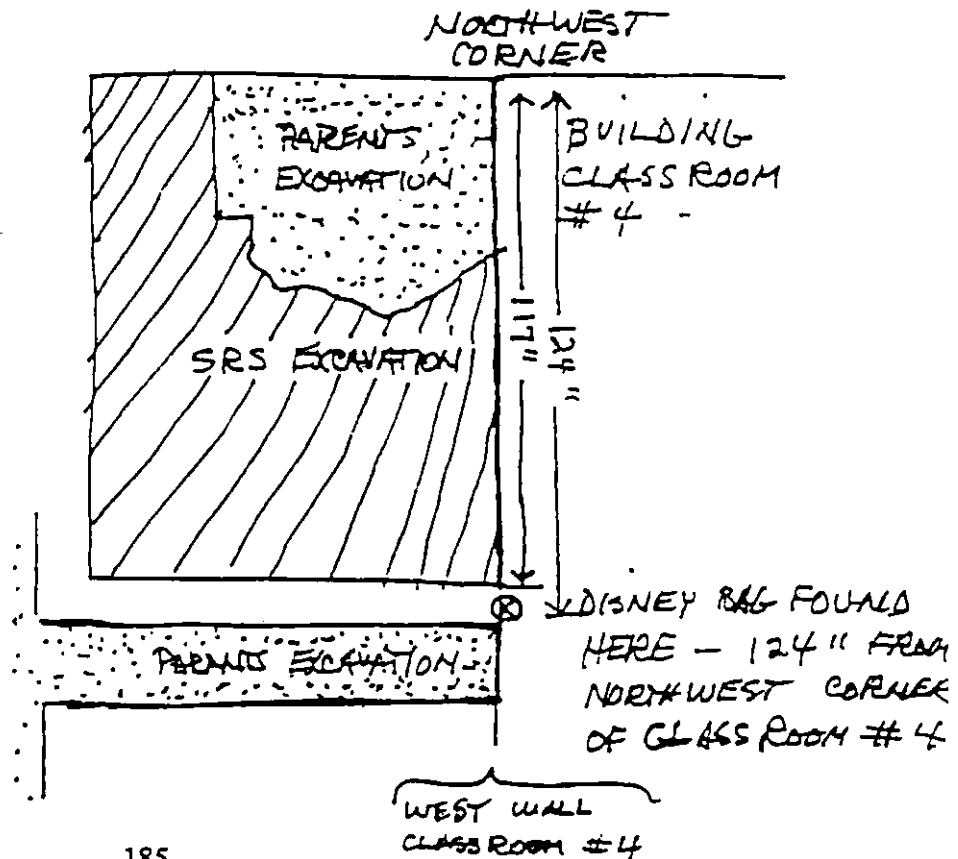

\* AF - ARTIFICIAL FILL

# TUNNEL ENTRANCE

## WEST WALL - UNDER CLASS ROOM #4 LOOKING EAST - DEPTH OF AVOCADO ROOT

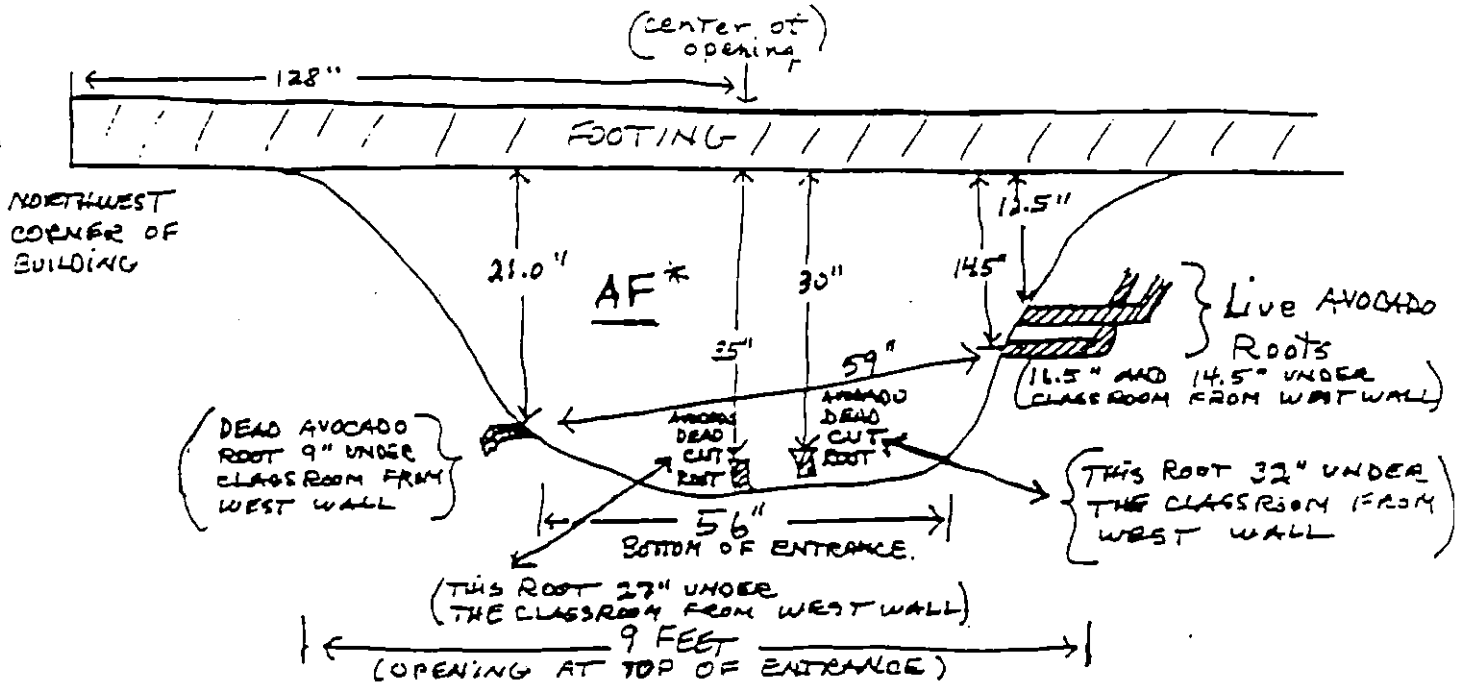

## AVOCADO ROOTS - TOP VIEW SHOWING LOCATION UNDER PRESCHOOL FOUNDATION CLASSROOM #4

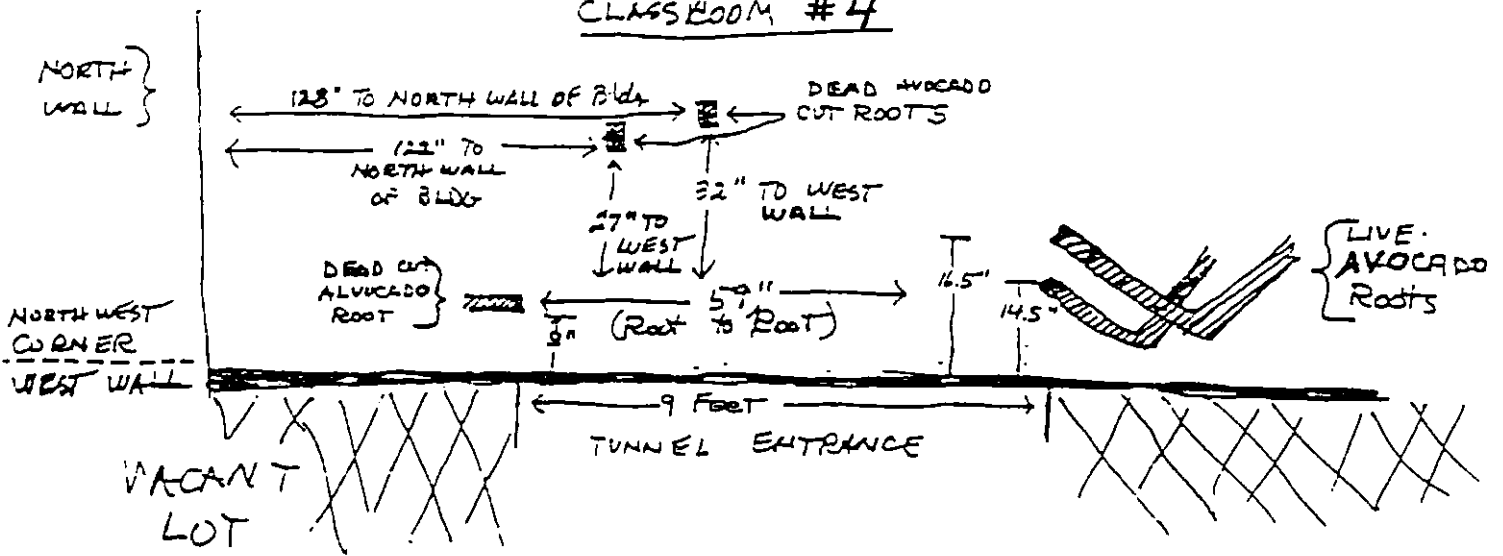

\* AF - ARTIFICIAL FILL